

*Midwest States' Regional Pooled Fund Research Program
Fiscal Years 2003-2005 (Years 14 and 15)
Research Project Number SPR-3(017)
NDOR Sponsoring Agency Code RFPF-04-04 and RFPF-05-06*

Approach Slope for Midwest Guardrail System

Submitted by

Erin A. Johnson
Undergraduate Research Assistant

Karla A. Lechtenberg, M.S.M.E., E.I.T.
Research Associate Engineer

John D. Reid, Ph.D.
Professor

Dean L. Sicking, Ph.D., P.E.
Professor and MwRSF Director

Ronald K. Faller, Ph.D., P.E.
Research Assistant Professor

Robert W. Bielenberg, M.S.M.E., E.I.T.
Research Associate Engineer

John R. Rohde, Ph.D., P.E.
Associate Professor

MIDWEST ROADSIDE SAFETY FACILITY

University of Nebraska-Lincoln
527 Nebraska Hall
Lincoln, Nebraska 68588-0529
(402) 472-0965

Submitted to

Midwest States' Regional Pooled Fund Program

Nebraska Department of Roads
1500 Nebraska Highway 2
Lincoln, Nebraska 68502

MwRSF Research Report No. TRP-03-188-08

December 4, 2008

TECHNICAL REPORT DOCUMENTATION PAGE

1. Report No. TRP-03-188-08	2.	3. Recipient's Accession No.	
4. Title and Subtitle Approach Slope for Midwest Guardrail System		5. Report Date December 4, 2008	
		6.	
7. Author(s) Johnson, E.A., Lechtenberg, K.A., Reid, J.D., Sicking, D.L., Faller, R.K., Bielenberg, R.W., and Rohde, J.R.		8. Performing Organization Report No. TRP-03-188-08	
9. Performing Organization Name and Address Midwest Roadside Safety Facility (MwRSF) University of Nebraska-Lincoln 527 Nebraska Hall Lincoln, Nebraska 68588-0529		10. Project/Task/Work Unit No.	
		11. Contract © or Grant (G) No. SRP-3(017)	
12. Sponsoring Organization Name and Address Midwest States' Regional Pooled Fund Program Nebraska Department of Roads 1500 Nebraska Highway 2 Lincoln, Nebraska 68502		13. Type of Report and Period Covered Final Report 2003-2008	
		14. Sponsoring Agency Code RPPF-04-04, RPPF-05-06	
15. Supplementary Notes Prepared in cooperation with U.S. Department of Transportation, Federal Highway Administration			
16. Abstract (Limit: 200 words) <p>AASHTO's Roadside Design Guide recommends that W-beam guardrails should not be placed on roadside slopes of 8:1 or steeper. This restriction often controls barrier placement decisions. Due to the slope limitations, designers are often faced with placing the guardrails near the edge of the shoulder. The long lengths of guardrail placed in close proximity to the edge of the shoulder greatly increases accident frequency with the guardrail. However, with the development of the Midwest Guardrail System, the mounting height and deeper blockout may provide improved performance to relax the recommendations provided in AASHTO's Roadside Design Guide.</p> <p>An LS-DYNA simulation study was conducted in order to determine the critical slope and associated offset for placement of the Midwest Guardrail System. An 8:1 slope was identified as the critical slope for the pickup truck impact condition, and the front face of the Midwest Guardrail System (MGS) was placed 1.5 m (5 ft) down from the slope break point.</p> <p>Two full-scale vehicle crash tests were performed on the system. The first was with a ¾-ton pickup truck, impacting the system at a speed and angle of 100.4 km/h (62.4 mph) and 25.9 degrees, respectively. The second crash test was performed using a small car, impacting the system with a speed and angle of 99.6 km/h (61.9 mph) and 21.6 degrees, respectively. Both tests were conducted and reported in accordance with requirements specified in the National Cooperative Highway Research Program (NCHRP) Report No. 350, <i>Recommended Procedures for the Safety Performance Evaluation of Highway Features</i> and were determined to be acceptable according to the Test Level 3 (TL-3) evaluation criteria.</p>			
17. Document Analysis/Descriptors Highway Safety, Roadside Appurtenances, Longitudinal Barrier, Guardrail, Approach Slope, Computer Simulation, MGS, Crash Test, Compliance Test.		18. Availability Statement No restrictions. Document available from: National Technical Information Services, Springfield, Virginia 22161	
19. Security Class (this report) Unclassified	20. Security Class (this page) Unclassified	21. No. of Pages 113	22. Price

DISCLAIMER STATEMENT

The contents of this report reflect the views of the authors who are responsible for the facts and the accuracy of the data presented herein. The contents do not necessarily reflect the official views nor policies of the State Highway Departments participating in the Midwest States' Regional Pooled Fund Research Program nor the Federal Highway Administration. This report does not constitute a standard, specification, or regulation.

ACKNOWLEDGMENTS

The authors wish to acknowledge several sources that made a contribution to this project:

(1) the Midwest States' Regional Pooled Fund Program funded by the Connecticut Department of Transportation, Illinois Department of Transportation, Iowa Department of Transportation, Kansas Department of Transportation, Minnesota Department of Transportation, Missouri Department of Transportation, Nebraska Department of Roads, New Jersey Department of Transportation, Ohio Department of Transportation, South Dakota Department of Transportation, Wisconsin Department of Transportation, and Wyoming Department of Transportation for sponsoring this project; and (2) MwRSF personnel for constructing the barriers and conducting the crash tests.

Acknowledgment is also given to the following individuals who made a contribution to the completion of this research project.

Midwest Roadside Safety Facility

J.C. Holloway, M.S.C.E., E.I.T., Research Manager
C.L. Meyer, B.S.M.E., E.I.T., Research Engineer II
S.K. Rosenbaugh, M.S.C.E., E.I.T., Research Associate Engineer
A.T. Russell, B.S.B.A., Laboratory Mechanic II
K.L. Krenk, B.S.M.A, Field Operations Manager
A.T. McMaster, Laboratory Mechanic I
Undergraduate and Graduate Assistants

Connecticut Department of Transportation

Dionysia Oliveira, P.E., Transportation Engineer 3

Illinois Department of Transportation

David Piper, P.E., Highway Policy Engineer

Iowa Department of Transportation

David Little, P.E., Assistant District Engineer
Deanna Mayfield, P.E., Methods Engineer
Chris Poole, P.E., Transportation Engineer Specialist

Kansas Department of Transportation

Ron Seitz, P.E., Bureau Chief
Rod Lacy, P.E., Assistant Bureau Chief
Scott King, P.E., Road Design Leader

Minnesota Department of Transportation

Michael Elle, P.E., Design Standard Engineer

Missouri Department of Transportation

Joseph G. Jones, P.E., Technical Support Engineer

Nebraska Department of Roads

Amy Starr, P.E., Research Engineer
Phil TenHulzen, P.E., Design Standards Engineer
Jodi Gibson, Research Coordinator

New Jersey Department of Transportation

Kiran Patel, P.E., P.M.P., C.P.M., Deputy State Transportation Engineer

Ohio Department of Transportation

Dean Focke, P.E., Standards Engineer

South Dakota Department of Transportation

David Huft, Research Engineer
Bernie Clocksin, Lead Project Engineer

Wisconsin Department of Transportation

John Bridwell, P.E., Standards Development Engineer
Erik Emerson, P.E., Standards Development Engineer

Wyoming Department of Transportation

William Wilson, P.E., Standards Engineer

Federal Highway Administration

John Perry, P.E., Nebraska Division Office

Danny Briggs, Nebraska Division Office

Dunlap Photography

James Dunlap, President and Owner

TABLE OF CONTENTS

TECHNICAL REPORT DOCUMENTATION PAGE	i
DISCLAIMER STATEMENT	ii
ACKNOWLEDGMENTS	iii
TABLE OF CONTENTS	vi
List of Figures	viii
List of Tables	x
1 INTRODUCTION	1
1.1 Problem Statement	1
1.2 Objective	2
2 LITERATURE REVIEW	3
3 TEST REQUIREMENTS AND EVALUATION CRITERIA	6
3.1 Test Requirements	6
3.2 Evaluation Criteria	6
4 TEST CONDITIONS	9
4.1 Test Facility	9
4.2 Vehicle Tow and Guidance System	9
4.3 Test Vehicles	9
4.4 Data Acquisition Systems	12
4.4.1 Accelerometers	12
4.4.2 Rate Transducers	17
4.4.3 High-Speed Photography	17
4.4.4 Pressure Tape Switches	18
5 CRITICAL SLOPE AND BARRIER PLACEMENT	21
6 MGS PLACED ON 8:1 SLOPE DESIGN DETAILS	24
7 FULL-SCALE CRASH TEST NO. 1	36
7.1 Test MGSAS-1	36
7.2 Test Description	36
7.3 Barrier Damage	37
7.4 Vehicle Damage	39
7.5 Occupant Risk Values	40
7.6 Discussion	40

8 FULL-SCALE CRASH TEST NO. 2	58
8.1 Test MGSAS-2	58
8.2 Test Description	58
8.3 Barrier Damage	59
8.4 Vehicle Damage	60
8.5 Occupant Risk Values	60
8.6 Discussion	61
9 SUMMARY, CONCLUSIONS, AND RECOMMENDATIONS	75
10 REFERENCES	78
11 APPENDICES	80
APPENDIX A - MGS Approach Slope Design Details, English Units	81
APPENDIX B - Test Summary Sheet in English Units	89
APPENDIX C - Occupant Compartment Deformation, Test No. MGSAS-1	92
APPENDIX D - Accelerometer and Rate Transducer Data Analysis, Test No. MGSAS-1	96
APPENDIX E - Occupant Compartment Deformation Data, Test No. MGSAS-2	104
APPENDIX F - Accelerometer and Rate Gyro Analysis, Test No. MGSAS-2	106

List of Figures

Figure 1. Test Vehicle, Test No. MGSAS-1	10
Figure 2. Vehicle Dimensions, Test No. MGSAS-1	11
Figure 3. Test Vehicle, Test No. MGSAS-2	13
Figure 4. Vehicle Dimensions, Test No. MGSAS-2	14
Figure 5. Target Geometry, Test No. MGSAS-1	15
Figure 6. Target Geometry, Test No. MGSAS-2	16
Figure 7. Camera Locations, Test No. MGSAS-1	19
Figure 8. Camera Locations, Test No. MGSAS-2	20
Figure 9. Simulation Results, MGS on 8-to-1 Slope with Rail 1.5 m (5 ft) Offset from Slope Break Point	23
Figure 10. System Layout	26
Figure 11. End Rail and Splice Details	27
Figure 12. Post Nos. 3 through 27 Details	28
Figure 13. Anchor Post Details	29
Figure 14. BCT Cable Anchor Details	30
Figure 15. Ground Strut and Anchor Bracket Details	31
Figure 16. Rail Section Details	32
Figure 17. Approach Slope for MGS System Detail	33
Figure 18. Post Details	34
Figure 19. Splice Details	35
Figure 20. Summary of Test Results and Sequential Photographs, Test No. MGSAS-1	42
Figure 21. Additional Sequential Photographs, Test No. MGSAS-1	43
Figure 23. Documentary Photographs, Test No. MGSAS-1	45
Figure 24. Documentary Photographs, Test No. MGSAS-1	46
Figure 25. Impact Location, Test No. MGSAS-1	47
Figure 26. Vehicle Trajectory and Final Position, Test No. MGSAS-1	48
Figure 27. System Damage, Test No. MGSAS-1	49
Figure 28. System Damage, Test No. MGSAS-1	50
Figure 29. Post Nos. 9 through 11 Damage, Test No. MGSAS-1	51
Figure 30. Post Nos. 12 through 15 Damage, Test No. MGSAS-1	52
Figure 31. Post Nos. 16 through 20 Damage, Test No. MGSAS-1	53
Figure 32. Anchorage Damage, Test No. MGSAS-1	54
Figure 33. Vehicle Damage, Test No. MGSAS-1	55
Figure 34. Vehicle Damage, Test No. MGSAS-1	56
Figure 35. Occupant Compartment Damage, Test No. MGSAS-1	57
Figure 36. Summary of Test Results and Sequential Photographs, Test No. MGSAS-2	62
Figure 37. Additional Sequential Photographs, Test No. MGSAS-2	63
Figure 38. Additional Sequential Photographs, Test No. MGSAS-2	64
Figure 39. Documentary Photographs, Test No. MGSAS-2	65
Figure 40. Documentary Photographs, Test No. MGSAS-2	66
Figure 41. Impact Location, Test No. MGSAS-2	67

Figure 42. Vehicle Trajectory and Final Position, Test No. MGSAS-2	68
Figure 43. System Damage, Test No. MGSAS-2	69
Figure 44. Post Nos. 14 through 16 Damage, Test No. MGSAS-2	70
Figure 45. Post Nos. 13 and 17 Damage, Test No. MGSAS-2	71
Figure 46. Upstream Anchorage Damage, Test No. MGSAS-2	72
Figure 47. Vehicle Damage, Test No. MGSAS-2	73
Figure 48. Vehicle Damage, Test No. MGSAS-2	74
Figure A-1. System Layout (English)	82
Figure A-2. End Rail and Splice Details (English)	83
Figure A-3. Post Nos. 3 through 27 Details	84
Figure A-4. Anchor Post Details	85
Figure A-5. BCT Cable Anchor Details (English)	86
Figure A-6. Ground Strut and Anchor Bracket Details (English)	87
Figure A-7. Rail Section Details	88
Figure B-1. Summary of Test Results and Sequential Photographs (English), Test No. MGSAS-1	90
Figure B-2. Summary of Test Results and Sequential Photographs (English), Test No. MGSAS-2	91
Figure C-1. Occupant Compartment Deformation Data - Set 1, Test No. MGSAS-1	93
Figure C-2. Occupant Compartment Deformation Data - Set 2, Test No. MGSAS-1	94
Figure C-3. Occupant Compartment Deformation Index (OCDI), Test No. MGSAS-1	95
Figure D-1. Graph of Longitudinal Deceleration, Test No. MGSAS-1	97
Figure D-2. Graph of Longitudinal Occupant Impact Velocity, Test No. MGSAS-1	98
Figure D-3. Graph of Longitudinal Occupant Displacement, Test No. MGSAS-1	99
Figure D-4. Graph of Lateral Deceleration, Test No. MGSAS-1	100
Figure D-5. Graph of Lateral Occupant Impact Velocity, Test No. MGSAS-1	101
Figure D-6. Graph of Lateral Occupant Displacement, Test No. MGSAS-1	102
Figure D-7. Graph of Roll, Pitch, and Yaw Angular Displacements, Test No. MGSAS-1 ...	103
Figure E-1. Occupant Compartment Deformation Index (OCDI), Test No. MGSAS-2	105
Figure F-1. Graph of Longitudinal Deceleration, Test No. MGSAS-2	107
Figure F-2. Graph of Longitudinal Occupant Impact Velocity, Test No. MGSAS-2	108
Figure F-3. Graph of Longitudinal Occupant Displacement, Test No. MGSAS-2	109
Figure F-4. Graph of Lateral Deceleration, Test No. MGSAS-2	110
Figure F-5. Graph of Lateral Occupant Impact Velocity, Test No. MGSAS-2	111
Figure F-6. Graph of Lateral Occupant Displacement, Test No. MGSAS-2	112
Figure F-7. Graph of Roll, Pitch, and Yaw Angular Displacements, Test No. MGSAS-2	113

List of Tables

Table 1. NCHRP Report No. 350 Test Level 3 Crash Test Conditions	7
Table 2. NCHRP Report No. 350 Evaluation Criteria for Crash Tests	8
Table 3. Initial Simulation Results	21
Table 4. Summary of Safety Performance Evaluation Results	77

1 INTRODUCTION

1.1 Problem Statement

A research study funded by the Federal Highway Administration (FHWA) in the late 1970's evaluated the performance of conventional guardrail systems when placed on a roadside slope (1-2). This study indicated that conventional W-beam guardrails should not be placed on roadside slopes of 6:1 or steeper. The American Association of State Highway and Transportation Officials' (AASHTO) Roadside Design Guide recommended that W-beam guardrails also should not be placed on roadside slopes steeper than 10:1. This restriction often controls barrier placement decisions (3). These slope limitations often force designers to place guardrails near the edge of the shoulder where roadside slopes are generally 10:1 or flatter. In this situation, guardrail installations must be much longer in order to properly protect motorists from severe roadside hazards. These long lengths of guardrail placed in close proximity to the edge of the shoulder greatly increases guardrail accident frequencies.

With the development of the Midwest Guardrail System (MGS), the higher mounting height and deeper blockout may provide sufficiently improved performance to relax the recommendations for not placing guardrails on slopes steeper than 10:1, as recommended in the Roadside Design Guide.

Furthermore, increasing the maximum slope where guardrail can be placed will allow many installations to be placed farther from the travelway. Moving guardrails farther from the travelway decreases the length of guardrail and greatly reduces impact frequency. Thus, allowing W-beam guardrail to be placed on steeper slopes should greatly reduce installation, maintenance, and accident costs.

1.2 Objective

The objective of this research project was to determine the critical slopes and associated offset for the MGS and to evaluate a critical slope and offset according to the Test Level 3 (TL-3) safety performance criteria set forth in the National Cooperative Highway Research Program (NCHRP) Report No. 350, *Recommended Procedures for the Safety Performance Evaluation of Highway Features* (4).

1.3 Scope

The research objective was achieved through the completion of several tasks. First, a literature search was performed on guardrail systems placed on roadside slopes. Second, a simulation study with LS-DYNA determined the critical slope and associated offset for placement of the MGS. Following the simulation study, two full scale tests were performed. The first test utilized a ¾-ton pickup truck, weighing approximately 2,000 kg (4,409 lbs), with a target impact speed and angle of 100.0 km/h (62.1 mph) and 25 degrees, respectively. The second test was performed using a small car, weighing approximately 820 kg (1,808 lbs), with a target impact speed and angle of 100 km/h (62.1 mph) and 20 degrees, respectively. Next, the test results were analyzed, evaluated, and documented. Finally, conclusions were made that pertain to the safety performance of the MGS system on a slope.

2 LITERATURE REVIEW

Barriers have been designed and tested for flat terrain conditions, even though they are generally placed on various terrains, such as slopes. The 1977 AASHTO Barrier Guide recommended that a roadside barrier should not be placed on an embankment with a slope greater than 10:1 (5). In the late 1970's, the Texas Transportation Institute (TTI) performed a study that determined the non-level terrain conditions for longitudinal barriers, evaluated the impact behavior of common barrier systems placed on non-level terrain, and developed guidelines for the selection and placement of barriers on non-level terrain (1-2).

Seven tests were conducted in this study, with four tests being conducted on standard G4(1S) W-beam guardrail with a top mounting height of 686 mm (27 in.) Above the ground at the front of the post (1-2). The study found that the G4(1S) system, placed at an offset of 3.66 m (12 ft) on a 6:1 slope, did not satisfy the structural adequacy requirements when impacted with a 2,043-kg (4,500-lb) vehicle at a speed of 101.2 km/h (62.9 mph) and an angle of 26.25 degrees as the rail ruptured and the vehicle penetrated the system. The G4(1S) system, placed at an offset of 1.83 m (6 ft) on a 6:1 slope, did not satisfy the structural adequacy requirements due to the vehicle vaulting over the system, when it was impacted with a 2,043-kg (4,500-lb) vehicle at a speed of 101.1 km/h (62.8 mph) and an angle of 25.0 degrees. The G4(1S) system, placed at a 1.83-m (6-ft) offset on a 6:1 slope, adequately contained and redirected a 2,043-kg (4,500-lb) vehicle impacting the system at a speed of 101.9 km/h (63.3 mph) and an angle of 14.75 degrees. The G4(1S) system, placed at an offset of 3.66 m (12 ft) on a 6:1 slope, also contained and redirected a 1,045-kg (2,300-lb) vehicle impacting at 93.6 km/h (58.2 mph) and an angle of 14.75 degrees. However, the tests that were able to redirect the vehicle had impact angles measuring 10 degrees less than that angle specified in the

safety performance criteria, and had trajectories that could pose a hazard to traffic in adjacent lanes (1-2).

From 1988 to 1992, ENSCO, Inc., conducted a study that investigated various guardrail applications (6). One of the tests, test no. 1862-15-92, involved a guardrail installation on sloped terrain. From the shoulder, the terrain was sloped at a 6:1 grade for 5.5 m (18 ft), at which point the guardrail was placed near the end of this grade. From this point, the terrain was sloped at a 2:1 grade for another 3.66 m (12 ft) behind the guardrail. The test satisfied all required criteria as specified in the AASHTO Guide Specifications for Bridge Railings (6). Following the crash tests, ENSCO researchers recommended that the post length for guardrails placed at the slope break point of a 2:1 slope should be 2,134 mm (7 ft) long and using a 1,905 mm (75 in.) post spacing.

In 2000, the Midwest Roadside Safety Facility (MwRSF) conducted a similar study (8-9). However, the guardrail design for placement at the slope break point of a 2:1 slope had to meet the criteria set forth in NCHRP Report No. 350. The posts used in this system were 2,134 mm (7 ft) long and were spaced at half-post spacings. One full-scale crash test was conducted on this system with a ¾-ton pickup truck, impacting the system 238 mm (9.4 in.) downstream from the centerline of post no. 17, at a speed of 100.7 km/h (62.6 mph) and an angle of 28.5 degrees, and was determined to be acceptable according to the TL-3 safety performance criteria presented in NCHRP Report No. 350.

In 2006, MwRSF conducted another study with W-beam barriers placed at the slope break point of a 2:1 slope (10-11). The new design incorporated a stiffened Midwest Guardrail System (MGS) barrier with an increased post length of 2,743 mm (9 ft) with standard post spacing. Two full-scale crash tests were performed on this system. For the first test, test no. MGS221-1, a 2,268-kg (5,000-lb) pickup truck impacted the MGS system, installed at the slope break point of a 2:1 slope

with a targeted top rail mounting height of 705 mm (27.75 in.). The actual top rail mounting height in the impact region was 702 mm (27.625 in.). This test was unsuccessful as the truck overrode the system and landed behind the system. The second test, test no. MGS221-2, involved a 2,274-kg (5,013-lb) pickup truck. The updated design had increased the rail mounting height to 787 mm (31 in.). This test was determined to be acceptable since the vehicle was smoothly redirected. Both tests were performed in accordance with the criteria set forth in the currently proposed Update to NCHRP Report No. 350 (12).

3 TEST REQUIREMENTS AND EVALUATION CRITERIA

3.1 Test Requirements

Historically, longitudinal barriers, such as W-beam guardrail systems, must satisfy impact safety standards provided in NCHRP Report No. 350 in order to be accepted by FHWA for use on National Highway System (NHS) new construction projects or as a replacement for existing designs not meeting current safety standards. According to TL-3 of NCHRP Report No. 350, longitudinal barrier systems must be subjected to two full-scale vehicle crash tests. The two full-scale crash tests are as follows:

1. Test Designation 3-10, consisting of an 820-kg (1,808-lb) small car impacting the guardrail system at a nominal speed and angle of 100.0 km/h (62.1 mph) and 20 degrees, respectively.
2. Test Designation 3-11, consisting of a 2,000-kg (4,409-lb) pickup truck impacting the guardrail system at a nominal speed and angle of 100.0 km/hr (62.1 mph) and 25 degrees, respectively.

The test conditions of TL-3 longitudinal barriers are summarized in Table 1.

3.2 Evaluation Criteria

According to NCHRP Report No. 350, the evaluation criteria for full-scale vehicle crash testing are based on three appraisal areas: (1) structural adequacy; (2) occupant risk; and (3) vehicle trajectory after collision. Criteria for structural adequacy are intended to evaluate the ability of the barrier to contain, redirect, or allow controlled vehicle penetration in a predictable manner. Occupant risk evaluates the degree of hazard to occupants in the impacting vehicle. Vehicle trajectory after collision is an indicator of the potential for the post-impact trajectory of the vehicle to cause subsequent multi-vehicle accidents. This criterion also indicates the potential safety hazard for the occupants of the other vehicles or the occupants of the impacting vehicle when subjected to

secondary collisions with other fixed objects. These three evaluation criteria are summarized in Table 2 and described in greater detail in NCHRP Report No. 350. Finally, the full-scale vehicle crash tests were conducted and reported in accordance with the procedures provided in NCHRP Report No. 350.

Table 1. NCHRP Report No. 350 Test Level 3 Crash Test Conditions

Test Article	Test Designation	Impact Conditions				Evaluation Criteria ¹
		Test Vehicle	Speed		Angle (degrees)	
			(km/h)	(mph)		
Longitudinal Barrier	3-10	820C	100	62.1	20	A,D,F,H,I,K,M
	3-11	2000P	100	62.1	25	A,D,F,K,L,M

¹Evaluation criteria explained in Table 2.

Table 2. NCHRP Report No. 350 Evaluation Criteria for Crash Tests

Structural Adequacy	A ·	Test article should contain and redirect the vehicle; the vehicle should not penetrate, underride, or override the installation although controlled lateral deflection of the test article is acceptable.
Occupant Risk	D ·	Detached elements, fragments or other debris from the test article should not penetrate or show potential for penetrating the occupant compartment, or present an undue hazard to other traffic, pedestrians, or personnel in a work zone. Deformations of, or intrusions into, the occupant compartment that could cause serious injuries should not be permitted.
	F.	The vehicle should remain upright during and after collision although moderate roll, pitching, and yawing are acceptable.
	H ·	Longitudinal and lateral occupant impact velocities should fall below the preferred value of 9 m/s (29.5 ft/s), or at least below the maximum allowable value of 12 m/s (39.4 ft/s).
	I.	Longitudinal and lateral occupant ridedown accelerations should fall below the preferred value of 15 g's, or at least below the maximum allowable value of 20 g's.
Vehicle Trajectory	K ·	After collision it is preferable that the vehicle's trajectory not intrude into adjacent traffic lanes.
	L.	The occupant impact velocity in the longitudinal direction should not exceed 12 m/s (39.4 ft/s), and the occupant ridedown acceleration in the longitudinal direction should not exceed 20 g's.
	M ·	The exit angle from the test article preferably should be less than 60 percent of the test impact angle measured at the time of vehicle loss of contact with the test device.

4 TEST CONDITIONS

4.1 Test Facility

The testing facility is located at the Lincoln Air Park on the northwest side of the Lincoln Municipal Airport and is approximately 8.0 km (5 mi.) northwest of the University of Nebraska-Lincoln.

4.2 Vehicle Tow and Guidance System

A reverse cable tow system with a 1:2 mechanical advantage was used to propel the test vehicle. The distance traveled and the speed of the tow vehicle were one-half that of the test vehicle. The test vehicle was released from the tow cable before impact with the barrier system. A digital speedometer on the tow vehicle increases the accuracy of the test vehicle impact speed.

A vehicle guidance system developed by Hinch ([13](#)) was used to steer the test vehicle. A guide-flag, attached to the front-left wheel and the guide cable, was sheared off before impact with the barrier system. The 9.5-mm (0.375-in.) diameter guide cable was tensioned to approximately 15.6 kN (3,500 lbf), and supported laterally and vertically every 30.48 m (100 ft) by hinged stanchions. The hinged stanchions stood upright while holding up the guide cable, but as the vehicle was towed down the line, the guide-flag struck and knocked each stanchion to the ground. For tests MGSAS-1 and MGSAS-2, the vehicle guidance systems were 333 m (1092 ft) and 239 m (783 ft), respectively.

4.3 Test Vehicles

For test MGSAS-1, a 1999 Chevrolet 2500 3/4-ton pickup truck was used as the test vehicle. The test inertial and gross static weights were 2,036 kg (4,489 lbs). The test vehicle is shown in Figure 1, and vehicle dimensions are shown in Figure 2.



Figure 1. Test Vehicle, Test No. MGSAS-1

Date: 7/26/2006 Test Number: MGSAS-1 Model: 2000P/ C2500
 Make: Chevy Vehicle I.D.#: 1GCGC24R7XR715972
 Tire Size: 245/75 R16 Year: 1999 Odometer: 189336

*(All Measurements Refer to Impacting Side)

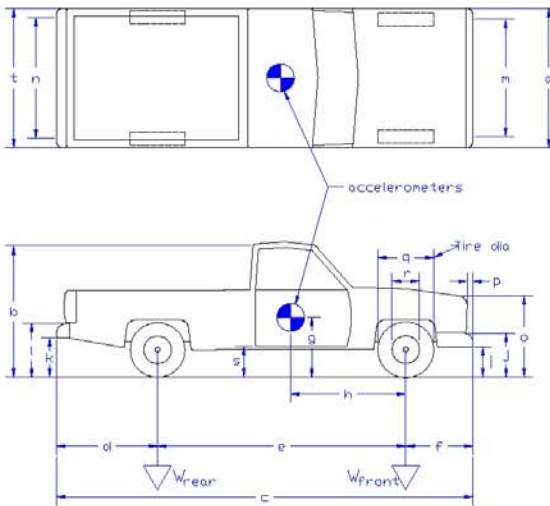

Vehicle Geometry - mm (in.)

a 1918 (75.5) b 1867 (73.5)
 c 5537 (218) d 1295 (51)
 e 3340 (131.5) f 908 (35.75)
 g 660 (26) h 1410 (55.5)
 i 184 (7.25) j 667 (26.25)
 k 584 (23) l 794 (31.25)
 m 1597 (62.875) n 1632 (64.25)
 o 1022 (40.25) p 102 (4)
 q 749 (29.5) r 445 (17.5)
 s 416 (16.375) t 1854 (73)

Wheel Center Height Front 368 (14.5)
 Wheel Center Height Rear 378 (14.875)
 Wheel Well Clearance (FR) 902 (35.5)
 Wheel Well Clearance (RR) 956 (37.625)

Frame Height (FR) 400 (15.75)
 Frame Height (RR) 679 (26.75)

Engine Type 8 CYL. GAS
 Engine Size 5.7 L 350 CID

Transmission Type:

Automatic or Manual
 FWD or RWD or 4WD

Weights	Curb	Test Inertial	Gross Static
kg (lbs)			
W _{front}	<u>1227 (2704)</u>	<u>1180 (2601)</u>	<u>1180 (2601)</u>
W _{rear}	<u>872 (1923)</u>	<u>856 (1888)</u>	<u>856 (1888)</u>
W _{total}	<u>2099 (4627)</u>	<u>2036 (4489)</u>	<u>2036 (4489)</u>

GVWR Rating

front 4100
 rear 6000
 total 8600

Note any damage prior to test: Right lower box side dented, left front bumper corner pushed in

Figure 2. Vehicle Dimensions, Test No. MGSAS-1

For test MGSAS-2, a 2000 Geo Metro was used as the test vehicle. The test inertial and gross static weights were 837 kg (1,845 lbs) and 912 kg (2,011 lbs), respectively. The test vehicle is shown in Figure 3, and vehicle dimensions are shown in Figure 4.

The longitudinal component of the center of gravity was determined using the measured axle weights. The location of the final center of gravity is shown in Figures 1 through 4.

Black and white checkered targets were placed on the vehicle to aid in the analysis of the high-speed videos, as shown in Figures 5 and 6. Checkered targets were placed on the C.G. on the driver's side door, passenger's side door, and roof of the vehicle. The remaining targets were located for reference so that they could be viewed from the high-speed cameras for film analysis.

The front wheels of the test vehicle were aligned for camber, caster, and toe-in values of zero so the vehicle would track properly along the guide cable. A 5B flash bulb was mounted on the right side of the vehicle's dash to pinpoint the time of impact with the test article on the high-speed video footage. The flash bulb was fired by a pressure tape switch mounted at the right corner of the bumper. A remote-controlled brake system was installed in the test vehicle so the vehicle could be brought safely to a stop after the test.

4.4 Data Acquisition Systems

Three data acquisition systems, two accelerometers and one rate transducer, were used to measure the motion of the vehicle. The results of all three were analyzed and plotted using "DynaMax 1 (DM-1)" and "DADiSP" computer software programs.

4.4.1 Accelerometers

One triaxial piezoresistive accelerometer system with a range of ± 200 g's was used to measure the acceleration of the longitudinal, lateral, and vertical directions at a sample rate of



Figure 3. Test Vehicle, Test No. MGSAS-2

Date: 9/6/2006 Test Number: MGSAS-2 Model: 820c/Metro
 Make: Chevrolet Vehicle I.D.#: 2C1MR224Y6726378
 Tire Size: 155/80 R13 Year: 2000 Odometer: 100114

*(All Measurements Refer to Impacting Side)

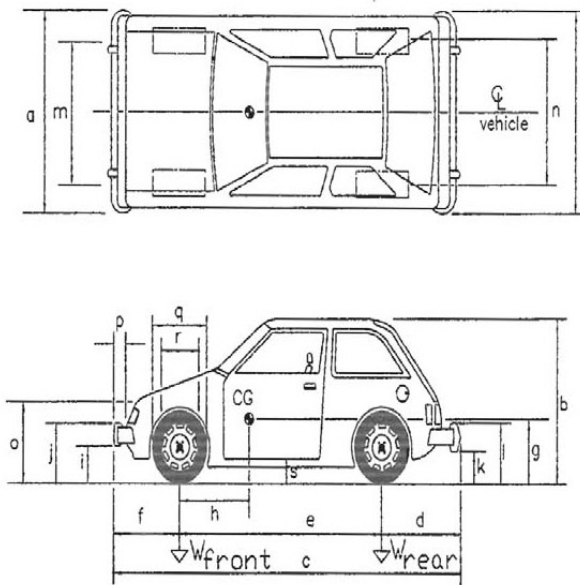

Vehicle Geometry -- mm (in.)

a	1555.8 (61.25)	b	1400.2 (55.125)
c	3803.7 (149.75)	d	803.25 (23.75)
e	2362.2 (93.0)	f	863.6 (34.0)
g	542.93 (21.375)	h	876.3 (34.5)
i	280.35 (10.25)	j	533.4 (21.0)
k	298.45 (11.75)	l	635 (25.0)
m	1378 (54.25)	n	1355.7 (53.375)
o	584.2 (23.0)	p	101.6 (4.0)
q	581.03 (22.875)	r	361.95 (14.25)
s	317.5 (12.5)	t	1562.1 (61.5)
Wheel Center Height Front		266.7 (10.5)	
Wheel Center Height Rear		289.88 (10.625)	
Wheel Well Clearance (FR)		654.05 (25.75)	
Wheel Well Clearance (RR)		644.53 (25.375)	

Engine Type 4 CYL. GAS
 Engine Size 1.3L
 Transmission Type: Automatic
FWD

Weights kg (lbs)	Curb	Test Inertial	Gross Static
W-front	<u>540.68 (1192)</u>	<u>527.53 (1163)</u>	<u>566.08 (1246)</u>
W-rear	<u>295.29 (651)</u>	<u>309.35 (682)</u>	<u>346.09 (763)</u>
W-total	<u>835.97 (1843)</u>	<u>836.88 (1845)</u>	<u>912.17 (2011)</u>

Note any damage prior to test: None

Figure 4. Vehicle Dimensions, Test No. MGSAS-2

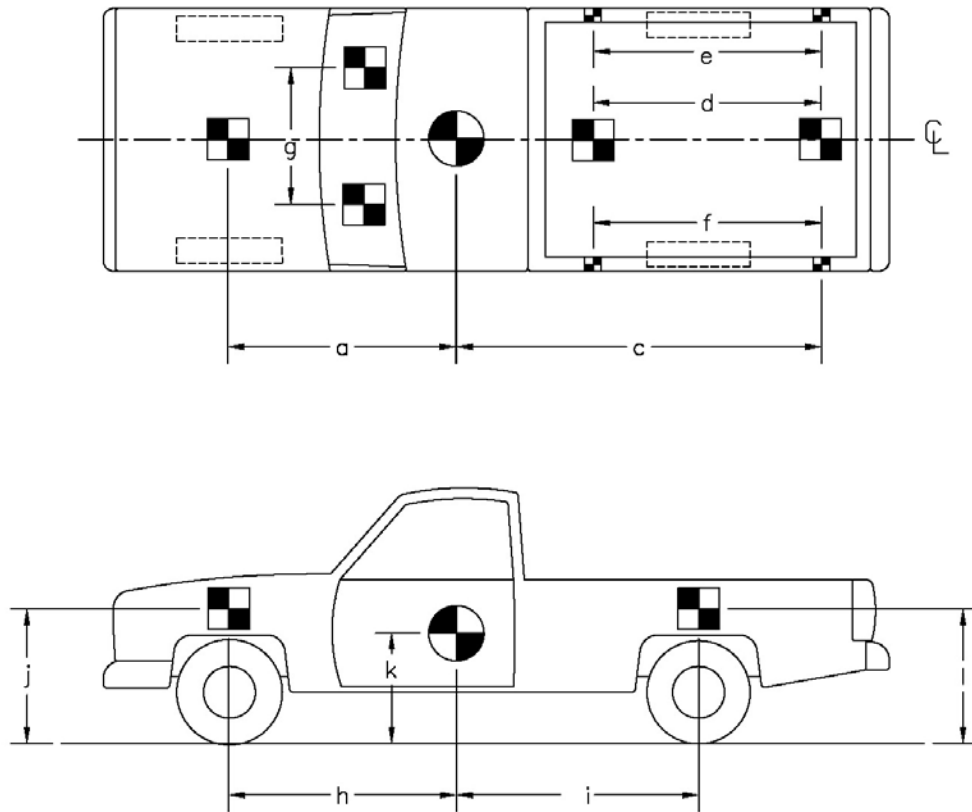

TEST #: MGSAS-1

TARGET GEOMETRY -- mm (in.)

a <u> 1610 (63.375)</u>	d <u> 1613 (63.5)</u>	g <u> 908 (35.75)</u>	j <u> 1022 (40.25)</u>
b <u> - </u>	e <u> 2149 (84.625)</u>	h <u> 1410 (55.5)</u>	k <u> 660 (26)</u>
c <u> 2604 (102.5)</u>	f <u> 2153 (84.75)</u>	i <u> 1924 (75.75)</u>	l <u> 1080 (42.5)</u>

Figure 5. Target Geometry, Test No. MGSAS-1

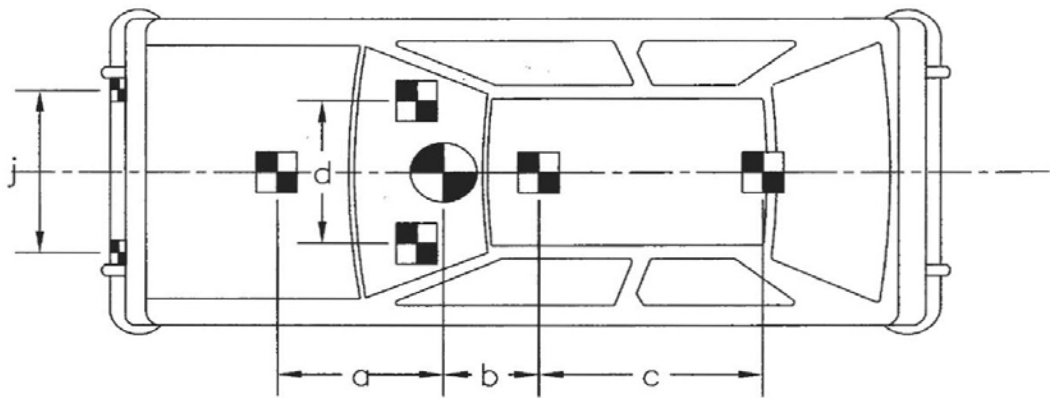

Side View

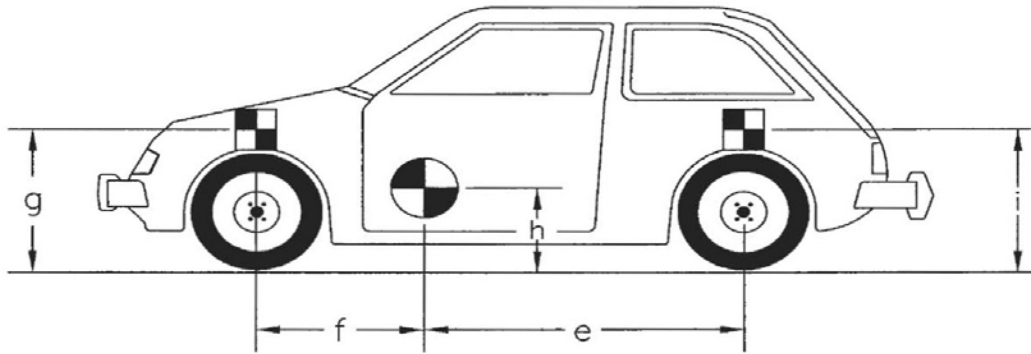

TEST #: <u>MGSAS-2</u>					
TARGET GEOMETRY-- mm (in.)					
A	<u>1184</u>	<u>(46.625)</u>	E	<u>1486</u>	<u>(58.5)</u>
B	<u>432</u>	<u>(17.0)</u>	F	<u>876</u>	<u>(34.5)</u>
C	<u>921</u>	<u>(36.25)</u>	G	<u>670</u>	<u>(26.375)</u>
D	<u>625</u>	<u>(24.625)</u>	H	<u>543</u>	<u>(21.375)</u>
I	<u>756</u>	<u>(29.75)</u>	J	<u>778</u>	<u>(30.625)</u>

Figure 6. Target Geometry, Test No. MGSAS-2

10,000 Hz. The environmental shock and vibration sensor/recorder system, Model EDR-4M6, was developed by Instrumented Sensor Technology (IST) of Okemos, Michigan, and includes three differential channels as well as three single-ended channels. The EDR-4 was configured with 6 MB of RAM memory and a 1,500 Hz lowpass filter.

Another triaxial piezoresistive accelerometer system with a range of ± 200 g's was also used to measure the acceleration in the longitudinal, lateral, and vertical directions at a sample rate of 3,200 Hz. The environmental shock and vibration sensor/recorder system, Model EDR-3, also developed by Instrumented Sensor Technology (IST) of Okemos, Michigan. The EDR-3 was configured with 256 kB of RAM memory and a 1,120 Hz lowpass filter.

4.4.2 Rate Transducers

An Analog Systems 3-axis rate transducer with a range of 1,200 degrees/sec in each of the three directions (pitch, roll, and yaw) was used to measure the rates of motion of the test vehicle. The rate transducer was mounted inside the body of the EDR-4M6 and recorded data at 10,000 Hz to a second data acquisition board inside the EDR-4M6 housing. The raw data measurements were then downloaded, converted to the appropriate Euler angles for analysis, and plotted.

4.4.3 High-Speed Photography

For test no. MGSAS-1, four high-speed AOS VITcam digital video cameras and one high-speed RedLake E/cam video camera, all with operating speeds of 500 frames/sec, were used to film the crash test. Five Canon digital video cameras and two JVC digital video cameras, all with standard operating speeds of 29.97 frames/sec, were also used to film the crash test. Camera details and a schematic of all twelve camera locations for test no. MGSAS-1 are shown in Figure 7.

For test MGSAS-2, five high-speed AOS VITcam video cameras, with operating speeds of

500 frames/sec, were used to film the crash test. Five Canon digital video cameras and two JVC digital video cameras, all with standard operating speeds of 29.97 frames/sec, were also used to film the crash test. Camera details and a schematic of all twelve camera locations for test no. MGSAS-2 are shown in Figure 8.

The AOS and E/cam videos were analyzed using ImageExpress MotionPlus software and Redlake Motion Scope software, respectively. Actual camera speed and camera divergence factors were considered in the analysis of the high-speed videos.

4.4.4 Pressure Tape Switches

For test nos. MGSAS-1 and MGSAS-2, five pressure-activated tape switches, spaced at 2-m (6.56-ft) intervals, were used to determine the speed of the vehicle before impact. Each tape switch fired a strobe light which sent an electronic timing signal to the data acquisition system as the right-front tire of the test vehicle passed over it. The test vehicle speed was then determined from the electronic timing mark data recorded using TestPoint software. Strobe lights and high-speed video analysis are used only as a backup in the event that vehicle speed cannot be determined from the electronic data.

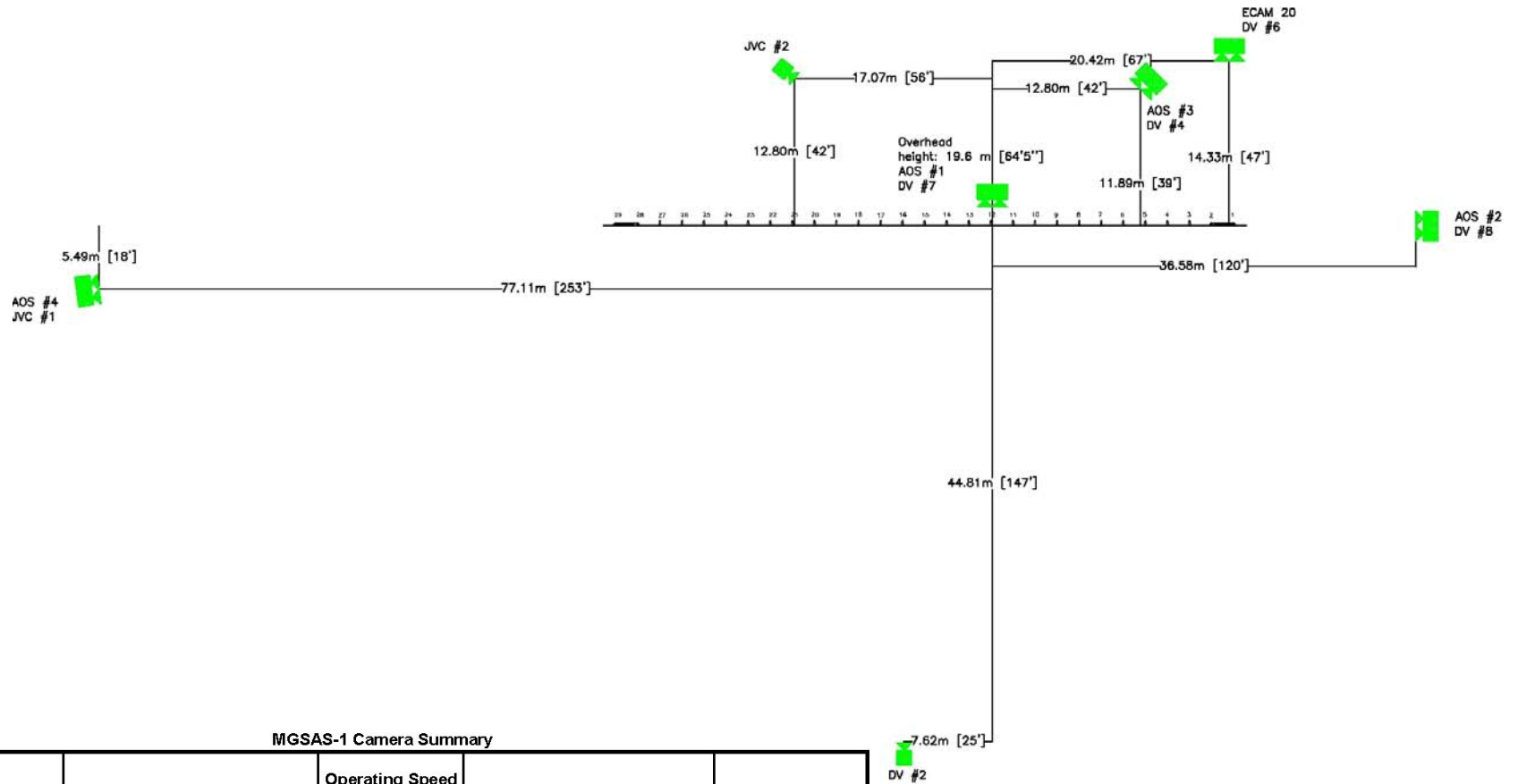

MGSAS-1 Camera Summary

	No.	Type	Operating Speed (frames/sec)	Lens	Lens Setting
High-Speed Video	1	Vitcam CTM	500	Cosmicar TV fixed 12.5 mm	
	2	Vitcam CTM	500	Sigma 24-135 mm	100 mm
	3	Vitcam CTM	500	Sigma 24-70 mm	35 mm
	4	Vitcam CTM	500	Sigma 70-200 mm	unknown
	20	Redlake E/Cam Camera	500	TV zoom 8048 mm	btwn 8 and 12
Digital Video	2	Canon-ZR10	29.97		
	4	Canon-ZR30	29.97		
	6	Canon-ZR25	29.97		
	7	Canon-ZR90	29.97		
	8	Canon-ZR90	29.97		
	1	JVC - GZ-MC500 (Everio)	29.97		
	2	JVC - GZ-MC40u (Everio)	29.97		

Figure 7. Camera Locations, Test No. MGSAS-1

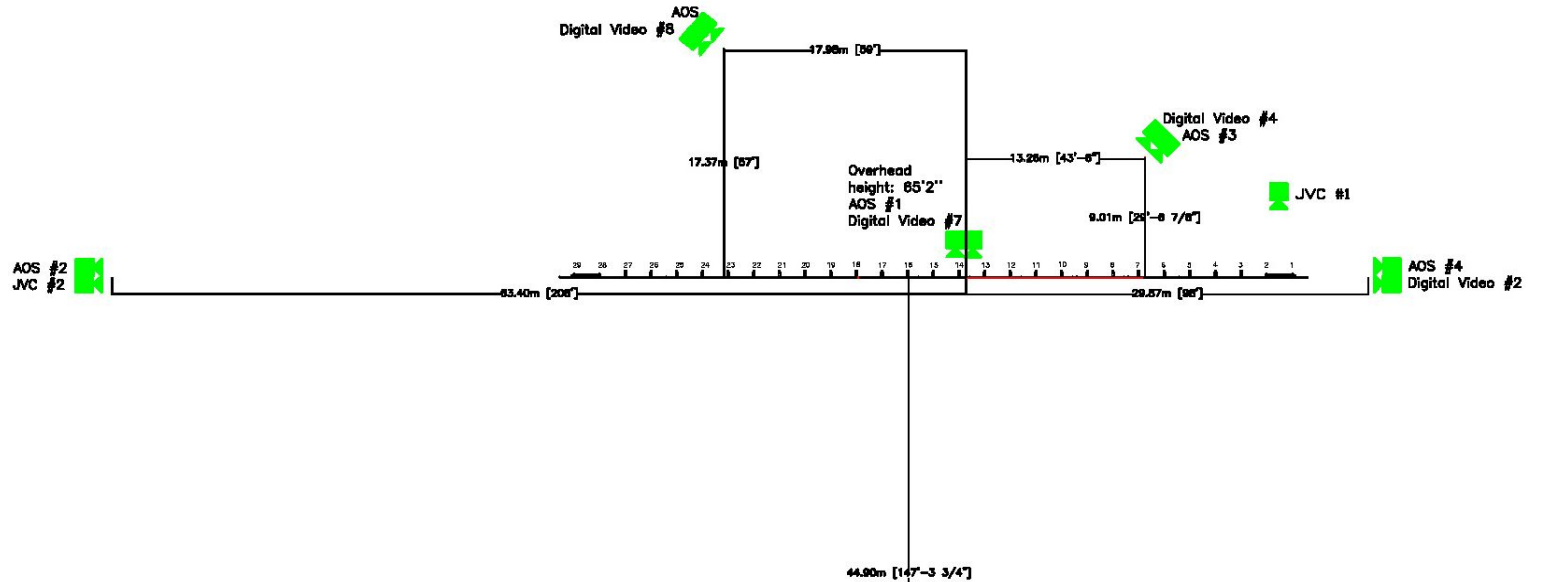

MGSAS-2 Camera Summary

20

	No.	Type	Operating Speed (frames/sec)	Lens	Lens Setting
High-Speed Video	1	Vitcam CTM	500	12.5 mm fixed	
	2	Vitcam CTM	500	Sigma 70-200	135 mm
	3	Vitcam CTM	500	Sigma 24-70	35 mm
	4	Vitcam CTM	500	50 mm fixed	
	7	Gigabit	500	Sigma 24-135	50 mm
Digital Video	2	Canon-ZR10	29.97		
	4	Canon-ZR30	29.97		
	6	Canon-ZR25	29.97		
	7	Canon-ZR90	29.97		
	8	Canon-ZR90	29.97		
	1	JVC - GZ-MC500 (Everio)	29.97		
	2	JVC - GZ-MC40u (Everio)	29.97		

Figure 8. Camera Locations, Test No. MGSAS-2

5 CRITICAL SLOPE AND BARRIER PLACEMENT

LS-DYNA simulation was used to help determine the critical slope and associated offset for placement of the MGS off of the roadway (14). The goal was to determine the steepest slope such that the MGS could be placed anywhere on that slope. Although not always the worst-case offset, a 1.5 m (5 ft) offset was determined to be the most comparable between various slopes. Thus, results from simulating a 2,000-kg (4,409-lb) pickup truck at 100 km/h (62.1 mph) and 25 degrees into an MGS placed with a 1.5 m (5 ft) offset from the break line were as reported in Table 3.

Table 3. Initial Simulation Results

Slope (H:V)	Results
10:1	truck redirected
9:1	truck redirected
8:1	messy, needed more analysis
7:1	looked like roll-over, numerical instabilities occurred, would be very lucky if it didn't roll-over if run was able to continue
6:1	truck rides over rail

Next, a more thorough analysis into the 8:1 slope system was performed. Part of this study included updating the MGS system model with more accurate details and investigating the truck model with and without some tear-away suspension components. The main differences in the MGS model was allowing the posts to rotate in the soil 127 mm (5 in.) higher than the previous model, a little stronger soil, and more refined contacts.

Some results of the refined simulations are shown in Figure 9. The 1.5 m (5 ft) offset, once again, proved to be the worst-case offset for the 8:1 slope system, using the pickup truck impact condition. Results, as indicated in Figure 9, were inconclusive; which supports this slope and barrier

placement as being the critical condition and thus, the recommended set-up for full-scale crash testing.

MGS on 8-to-1 slope, rail 1.5 m (5 ft) offset from slope break point
 Pickup truck – 100 km/h (62.1 mph) at 25 degrees.

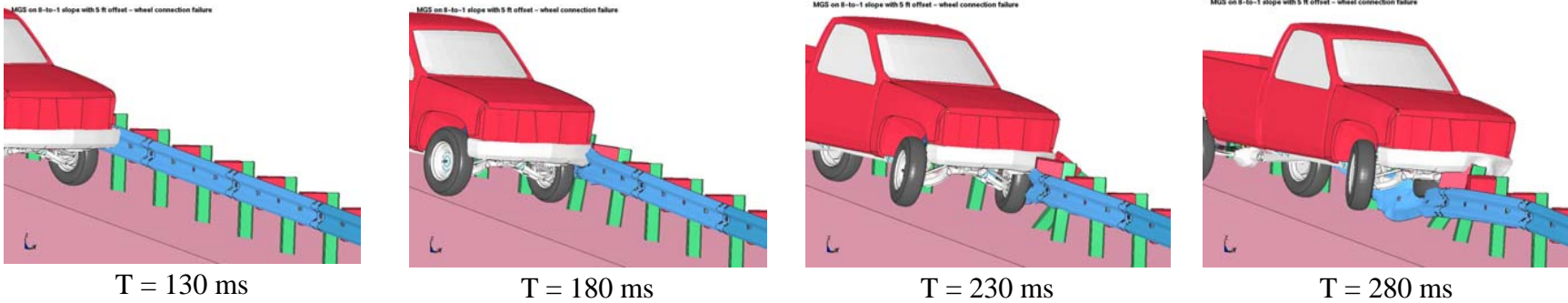

Wheel-Suspension Connection Failure Allowed – wheel comes off, truck overrides system

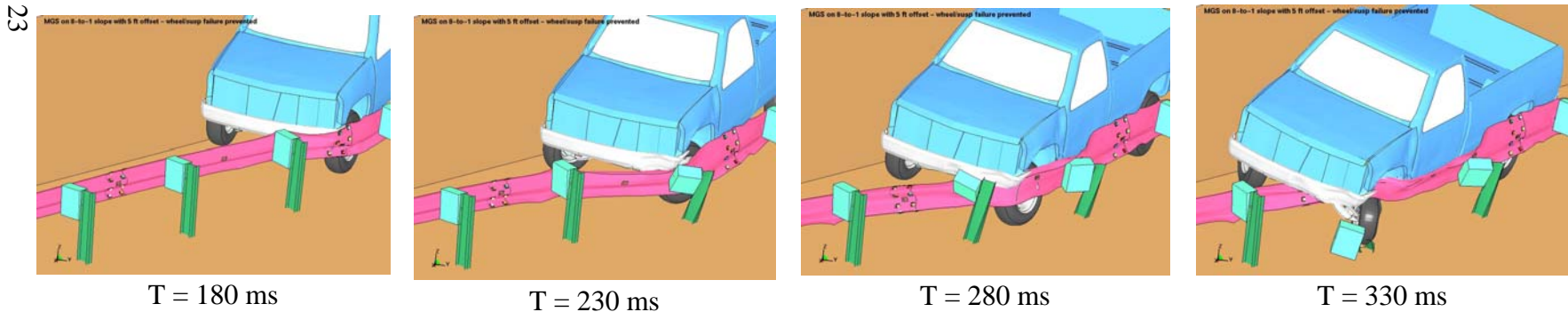

No Connection Failure Allowed – rail tries to capture via tire, gets jammed up into wheel-well
 This could cause rail rupture or vehicle roll-over.

Figure 9. Simulation Results, MGS on 8-to-1 Slope with Rail 1.5 m (5 ft) Offset from Slope Break Point

6 MGS PLACED ON 8:1 SLOPE DESIGN DETAILS

The test installation consisted of 53.34 m (175 ft) of standard 2.66-mm (12-gauge) thick, W-beam guardrail supported by steel posts, as shown in Figure 10. Anchorage systems similar to those used on tangent guardrail terminals were utilized on both the upstream and downstream ends of the guardrail system. Design details are shown in Figures 10 through 16. The corresponding English-unit drawings are shown in Appendix A. Photographs of the test installation are shown in Figures 17 through 19.

The entire system was constructed with twenty-nine guardrail posts. Post nos. 3 through 27 were galvanized ASTM A36 steel W152x13.4 (W6x9) sections measuring 1,829 mm (6 ft) in length. Post nos. 1, 2, 28, and 29 were timber posts measuring 140-mm wide x 190-mm deep x 1,080-mm long (5.5-in. x 7.5-in. x 42.5-in.) and were placed in 1,829-mm (6-ft) long steel foundation tubes, as shown in Figure 13. The timber posts and foundation tubes were part of anchor systems designed to replicate the capacity of a tangent guardrail terminal.

Post nos. 1 through 29 were spaced 1,905 mm (75 in.) on center. A soil embedment depth of 959 mm (37.75 in.) was located at the back of the posts on the embankment. The posts were placed in a compacted, coarse, crushed limestone material that met Grading B of AASHTO M147-65 (1990) as found in NCHRP Report No. 350. For post nos. 3 through 27, 152-mm wide x 305-mm deep x 362-mm long (6-in. x 12-in. x 14.25-in.) wood spacer blockouts were used to block the rail away from the front face of the steel posts.

Standard 2.66-mm (12-gauge) thick W-beam rails with additional post bolt slots at half post spacing intervals were placed between post nos. 1 and 29, as shown in Figures 10 and 16. The W-beam's top rail height was 787 mm (31 in.) with a 632 mm (24.875 in.) center mounting height when

measured from the top of the rail to the ground directly below the rail. The rail splices were moved to the center of the span location, as show in Figures 11 and 16. All lap-splice connections between the rail sections were configured to reduce vehicle snag at the splices during the crash test.

An 8:1 foreslope was excavated in the pit, as shown in Figures 10 and 12. The maximum pit dimensions were 6,096 mm (20 ft) wide and 762 mm (2.5 ft) deep. The length of the pit spanned the entire length of the guardrail system. The standard MGS system was placed 1,524 mm (5 ft) down the slope from the slope break point, as shown in Figure 10.

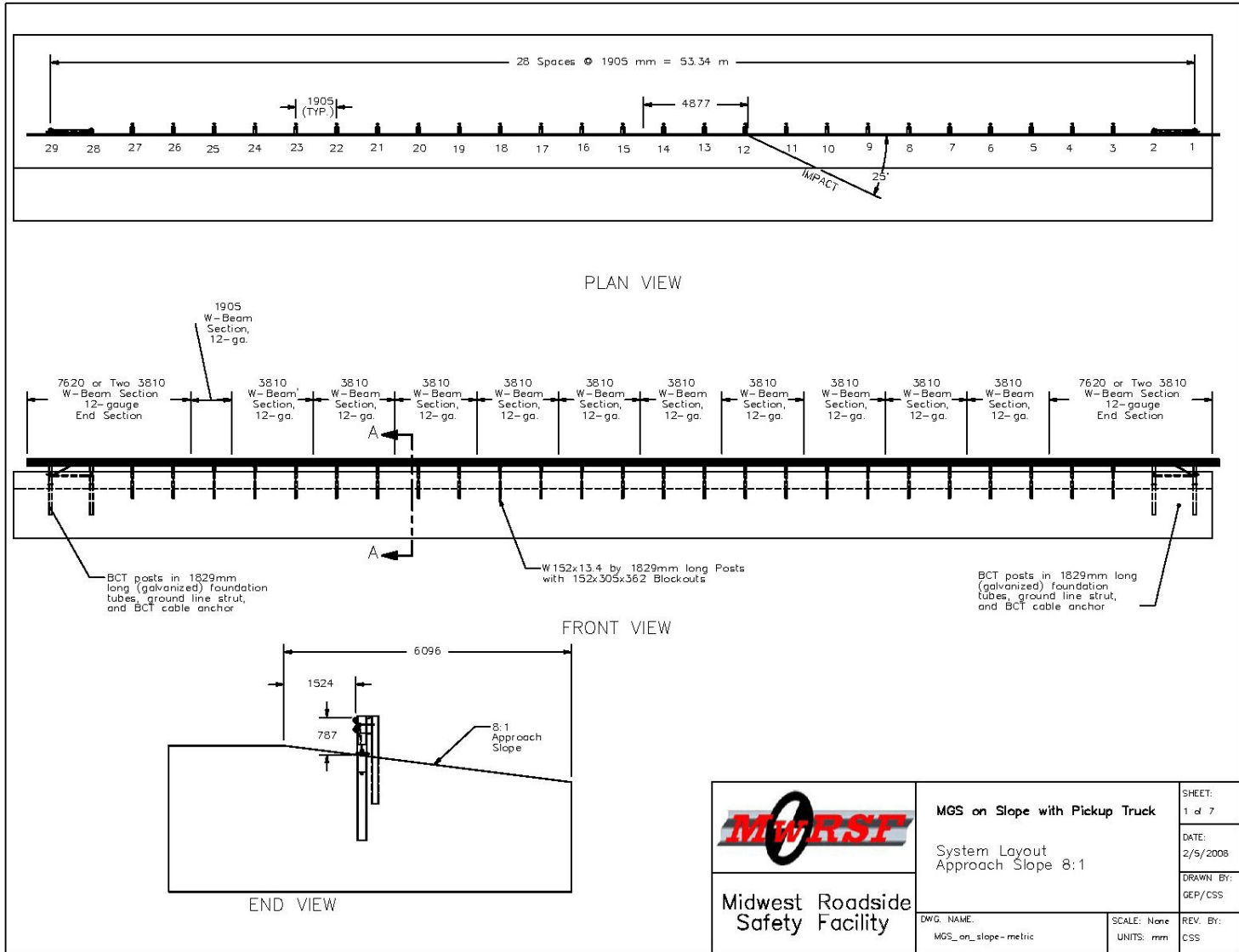

Figure 10. System Layout

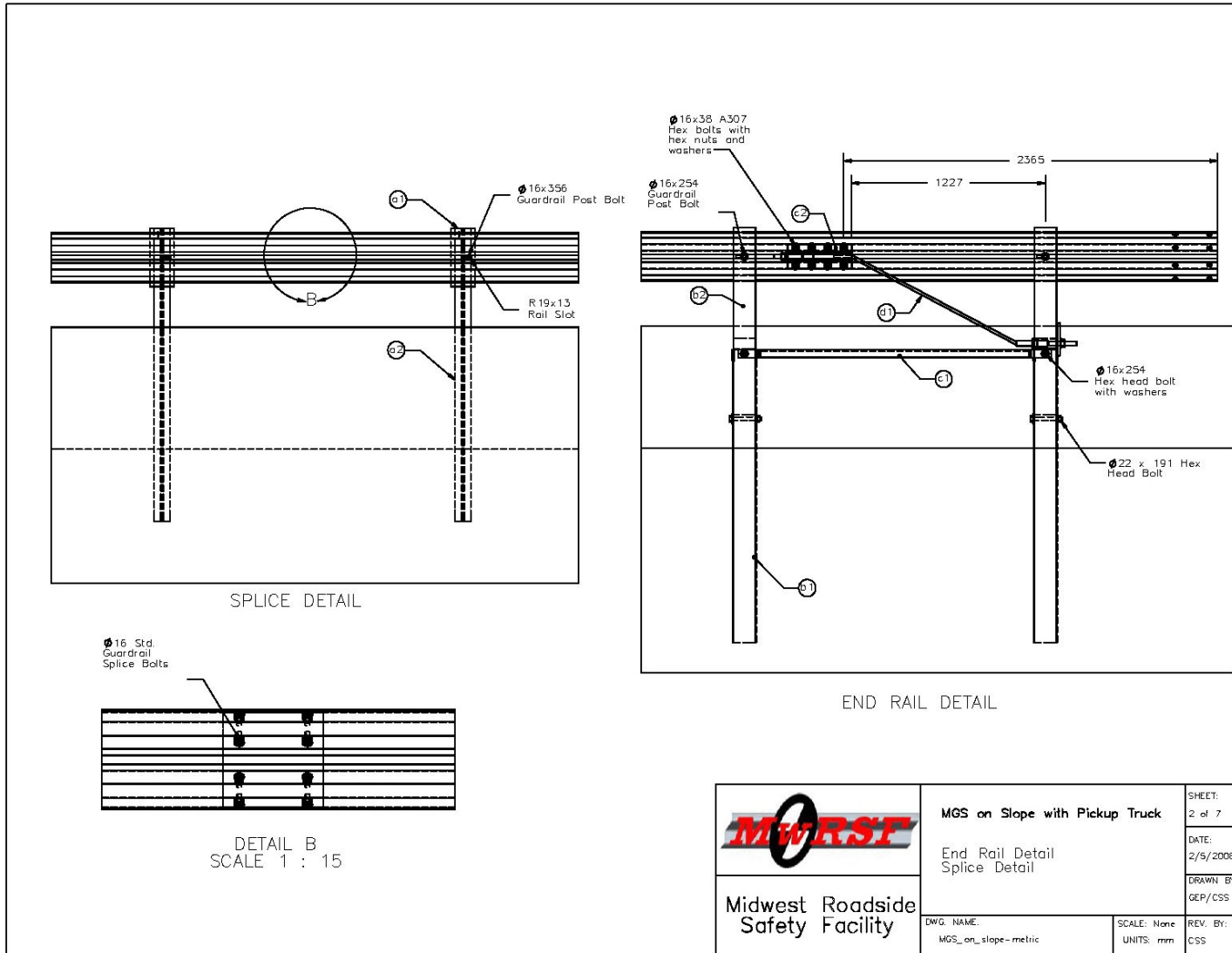

Figure 11. End Rail and Splice Details

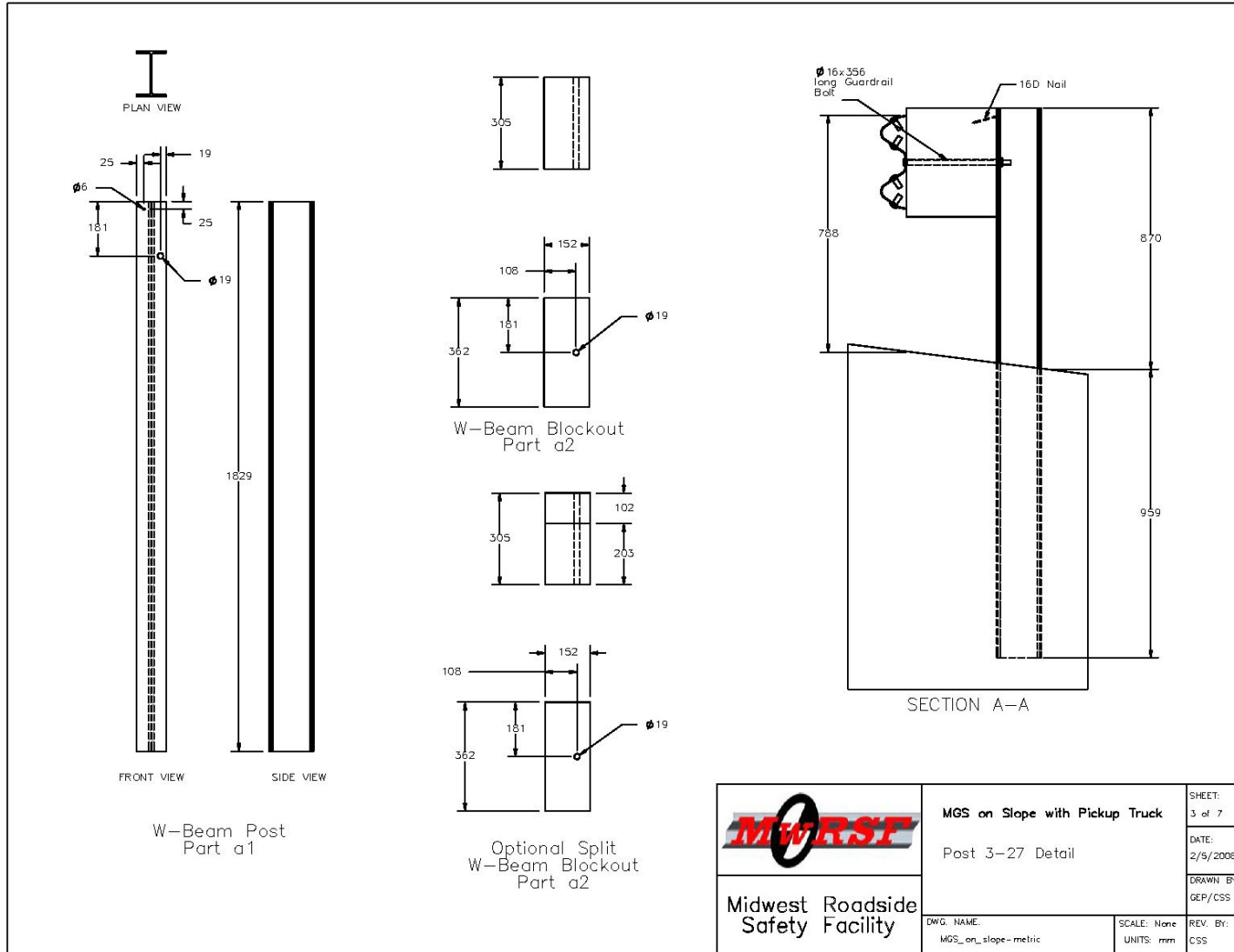

Figure 12. Post Nos. 3 through 27 Details

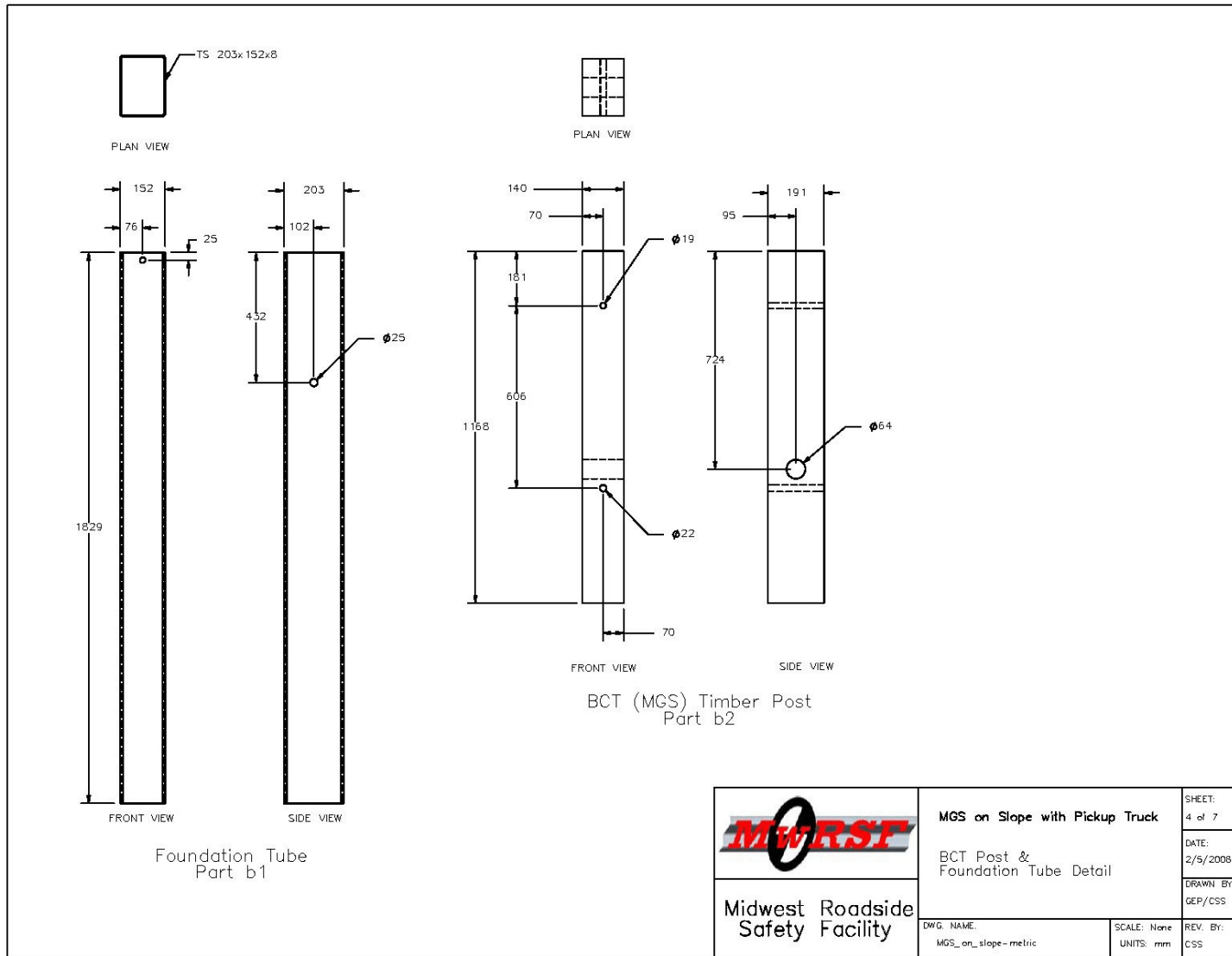

Figure 13. Anchor Post Details

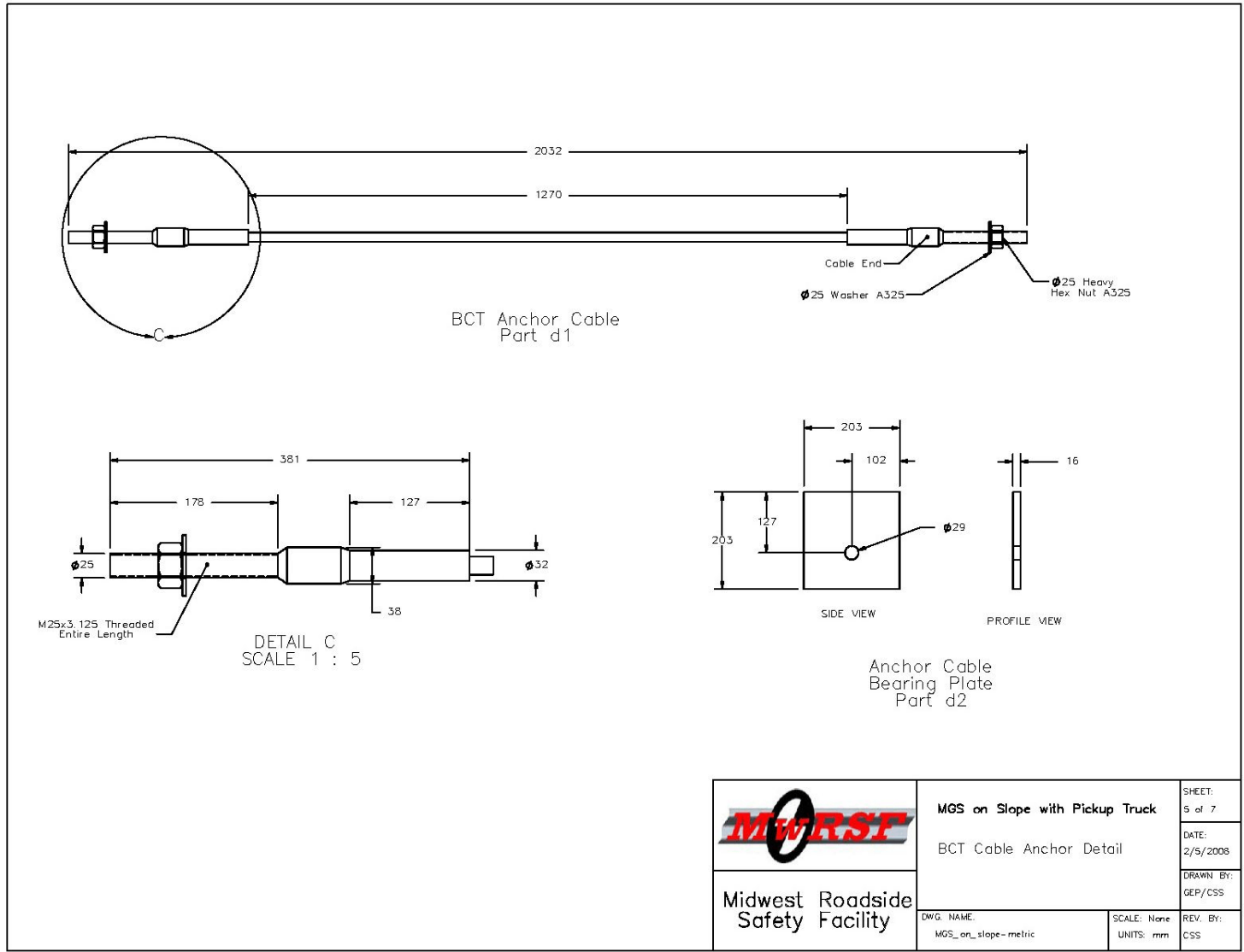

Figure 14. BCT Cable Anchor Details

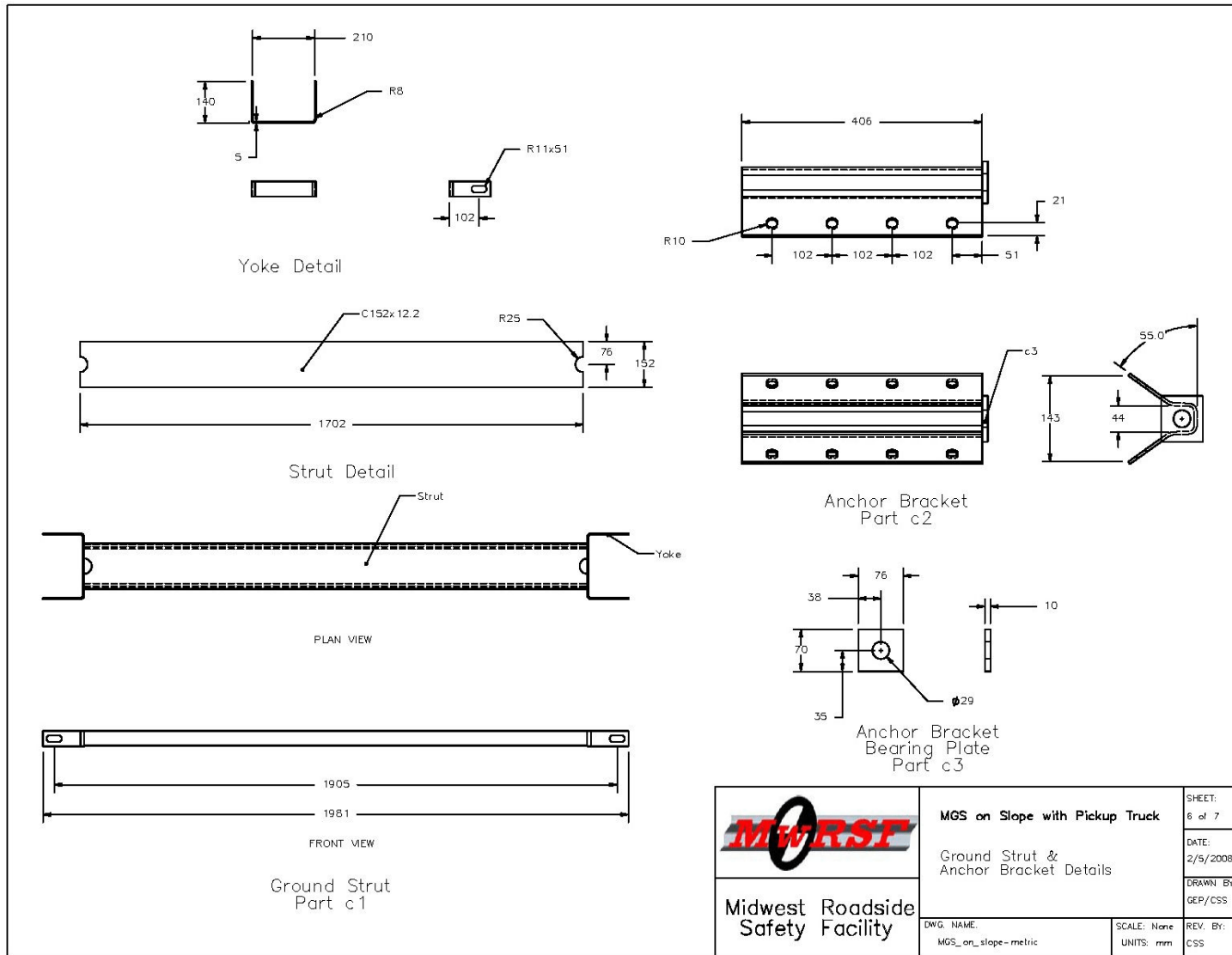

Figure 15. Ground Strut and Anchor Bracket Details

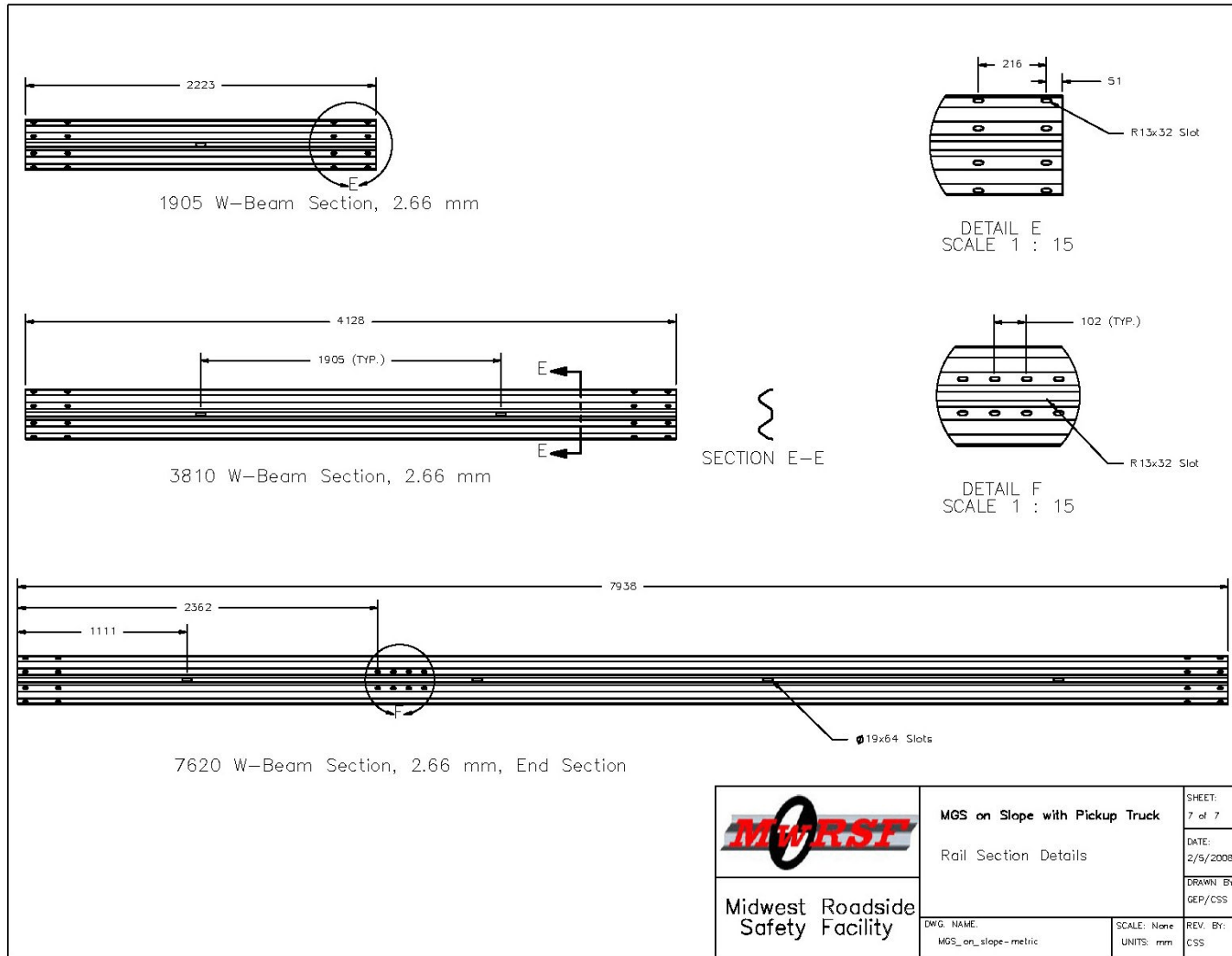

Figure 16. Rail Section Details



Figure 17. Approach Slope for MGS System Detail



Figure 18. Post Details



Figure 19. Splice Details

7 FULL-SCALE CRASH TEST NO. 1

7.1 Test MGSAS-1

The 2,036-kg (4,489-lb) pickup truck impacted the MGS, placed 1,524 mm (5 ft) down from the slope break point at a speed of 100.4 km/h (62.4 mph) and at an angle of 25.9 degrees. A summary of the test results and sequential photographs are shown in Figure 20. The summary of the test results and sequential photographs in English units are shown in Appendix B. Additional sequential photographs are shown in Figures 21 and 22. Documentary photographs of the crash test are shown in Figures 23 and 24.

7.2 Test Description

Initial vehicle impact was to occur between post nos. 11 and 12, or 4.88 m (16 ft) upstream from the centerline of the splice between post nos. 14 and 15, as shown in Figures 10 and 25. Actual vehicle impact occurred 4.83 m (15 ft - 10 in.) upstream from the centerline of the splice between post nos. 14 and 15. At 0.004 sec after impact, post no. 12 deflected backward, and the rail deformed. At this same time, the right-front corner of the bumper deformed. At 0.012 sec, post nos. 11 and 13 deflected backward. At 0.030 sec, post no. 14 deflected backward, and a dent formed on the right-front corner of the hood. At 0.040 sec, the left-front tire was located on the slope. At 0.070 sec, the rail deformed. At 0.086 sec, the right-front tire contacted the rail. At 0.092 sec, the rail wrapped around the front of the vehicle. At 0.098 sec, post no. 16 deflected backward. At 0.124 sec, the right-front corner of the bumper protruded over the rail, and the blockout at post no. 13 disengaged from the system. At 0.158 sec, the vehicle began to redirect. At 0.164 sec, the blockout at post no. 14 disengaged from the system. At 0.192 sec, the entire front bumper protruded over the rail. At 0.258 sec, the rail wrapped around post no. 16. At this same time, the left side of the vehicle

began to rise off the ground. At 0.298 sec, the rail caught between the right-front tire and the vehicle. At 0.324 sec, the left-rear tire became airborne. At 0.344 sec, the entire left side of the truck was airborne. At 0.456 sec, the vehicle yawed toward the rail. At 0.480 sec, the rear of the vehicle pitched upward. At 0.512 sec, the vehicle exhibited significant roll clockwise toward the rail. At 0.562 sec, the rear and left sides of the vehicle continue to rise upward with the right-front tire in contact with the rail. At 0.676 sec, the left side of the vehicle descended toward the ground. At 0.732 sec, the right-rear tire was positioned over the rail. At 0.752 sec, the right-front tire folded back under the vehicle. At 0.948 sec, the rear of the truck reached its highest point in the air. At 1.256 sec, the left-front tire contacted the ground. At 1.266 sec, the truck was parallel with the system, at a speed of 33.1 km/h (20.55 mph). At 1.370 sec, the left-rear tire contacted the ground. At 1.388 sec, the right side of the vehicle remained in contact with the rail. At 1.644 sec, the vehicle exhibited roll toward the right. At 1.798 sec, post nos. 20 and 21 deflected. At 2.076 sec, all tires of the vehicle were back in contact with the ground. The vehicle came to rest 21.6 m (70 ft - 10.5 in.) downstream from impact and with the right side of the vehicle against the traffic-side face of the guardrail system. The trajectory and final position of the pickup truck are shown in Figures 20 and 26.

7.3 Barrier Damage

Damage to the barrier was moderate, as shown in Figures 27 through 32. Barrier damage consisted of deformed guardrail posts, disengaged and fractured wooden blockouts, contact marks on a guardrail section, and deformed W-beam rail. The length of vehicle contact along the system was approximately 24.7 m (81 ft - 1 in.), which spanned from 64 mm (2.5 in.) upstream from the centerline of post no. 12 through the centerline of post no. 24.

Moderate deformation and flattening of the impacted section of W-beam rail occurred between post nos. 13 and 18. Contact marks were also found on the guardrail between post nos. 13 and 18. A minor buckle occurred in the rail near post no. 2. A major portion of the buckling occurred between post nos. 13 and 17. Substantial buckling of the rail occurred at post no. 18 and minor buckling occurred between post nos. 19 and 23. The W-beam pulled off of post nos. 2, 3, 6, 7, 14 through 16, 18, and 21. Tearing was found at the post bolt slots at post nos. 13 through 18. A 114-mm (4.5-in.) long tear occurred in the top corrugation at post no. 14. A 152-mm (6-in.) long tear was found in the top corrugation of the W-beam at post no. 17. No significant guardrail damage occurred downstream of post no. 23.

Steel post nos. 3 through 5, 8 through 12, and 19 were twisted slightly. Post nos. 10 through 13 rotated and bent backward. Post no. 14 rotated backward and bent downstream with the top of the post only 280 mm (11 in.) from the ground. Post no. 15 rotated 90 degrees and bent downstream. Post no. 16 remained undeformed, but was completely uprooted from the ground. Post no. 17 rotated and bent downstream to a 45 degree angle. Post no. 18 deflected backward. No damage occurred to post nos. 19 through 25. The upstream anchor moved longitudinally downstream approximately 51 mm (2 in.). All four wood BCT posts remained undamaged.

The wooden blockouts at post nos. 3 through 12 rotated slightly downstream. The wooden blockout at post nos. 13 and 22 were split, but remained attached to the posts. The wooden blockouts at post nos. 14 through 16 and 18 were fractured and removed from the post. The wooden blockouts at post nos. 17, 19, 20, 23, and 24 were rotated downstream.

The permanent set of the barrier system is shown in Figure 27. The maximum lateral permanent set rail and post deflections were 870 mm (34.25 in.) at the midspan between post nos.

16 and 17 and 806 mm (31.75 in.) at post no. 14, respectively, as measured in the field. The maximum lateral dynamic rail and post deflections were 1,464 mm (57.6 in.) at the midspan between post nos. 13 and 14 and 1,002 mm (39.5 in.) at post no. 13, respectively, as determined from high-speed digital video analysis. It should be noted that the rail was removed from the posts. The working width of the system was found to be 2,104 mm (82.8 in.).

7.4 Vehicle Damage

Exterior vehicle damage was minimal, as shown in Figures 33 through 35. Occupant compartment deformations to the right side and center of the floorboard were judged insufficient to cause serious injury to the vehicle occupants, as shown in Figure 35. Maximum longitudinal deflections of 6 mm (0.25 in.) were located near the left side of the right side floorboard. Maximum lateral deflections of 19 mm (0.75 in.) were located near the front of the right-side floorboard. Maximum vertical deflections of 19 mm (0.75 in.) were located near the left side of the right-side floorboard. Complete occupant compartment deformations and the corresponding locations are provided in Appendix C.

Damage was concentrated on the right-front corner of the vehicle. The right-front tire disengaged from the upper control arm and rotated to parallel with the ground. The right-front wheel well was deformed. The right-front tire bead was broken and the steel rim was severely damaged. The right-front corner of the bumper was deformed upward and inward toward the engine compartment, and the left-front corner of the bumper deformed away from the truck. The right-front quarter panel encountered buckling and was pushed upward and inward into the engine compartment. The right-front frame was buckled. The right-side door encountered scratches along the lower portion of the door. Deformation on the cab was found near the right-side door. The truck

bed was deformed away from the cab of the truck. The roof, hood, left side, and rear of the vehicle, and all window glass remained undamaged.

7.5 Occupant Risk Values

The longitudinal and lateral occupant impact velocities were determined to be -6.16 m/s (-20.20 ft/s) and -3.43 m/s (-11.27 ft/s), respectively. The maximum 0.010-sec average occupant ridedown decelerations in the longitudinal and lateral directions were -9.49 g's and -6.43 g's, respectively. It is noted that the occupant impact velocities (OIVs) and occupant ridedown decelerations (ORDs) were within the suggested limits provided in NCHRP Report No. 350. The THIV and PHD values were determined to be 6.90 m/s (22.64 ft/s) and 11.00 g's, respectively. The results of the occupant risk, as determined from the accelerometer data, are summarized in Figure 20. Results are shown graphically in Appendix D. The results from the rate transducer are shown graphically in Appendix D.

7.6 Discussion

The analysis of the test results for test no. MGSAS-1 showed that the MGS placed 1,524 mm (5 ft) down from the slope break point of an 8:1 slope adequately contained and redirected the 2000P vehicle with controlled lateral displacements of the barrier system. There were no detached elements nor fragments which showed potential for penetrating the occupant compartment nor presented undue hazard to other traffic. Deformations of, or intrusion into, the occupant compartment that could have caused serious injury did not occur. The test vehicle did not penetrate nor ride over the guardrail system and remained upright during and after the collision. Vehicle roll, pitch, and yaw angular displacements were noted, but they were deemed acceptable because they did not adversely influence occupant risk safety criteria nor cause rollover. After collision, the vehicle's trajectory

revealed no intrusion into adjacent traffic lanes, as it came to rest against the guardrail. In addition, the vehicle's exit angle was less than 60 percent of the impact angle. Therefore, test no. MGSAS-1 conducted on the MGS placed 1,524 mm (5 ft) down from the slope break point of an 8:1 slope was determined to be acceptable according to the TL-3 safety performance criteria of test designation no. 3-11 found in NCHRP Report No. 350.

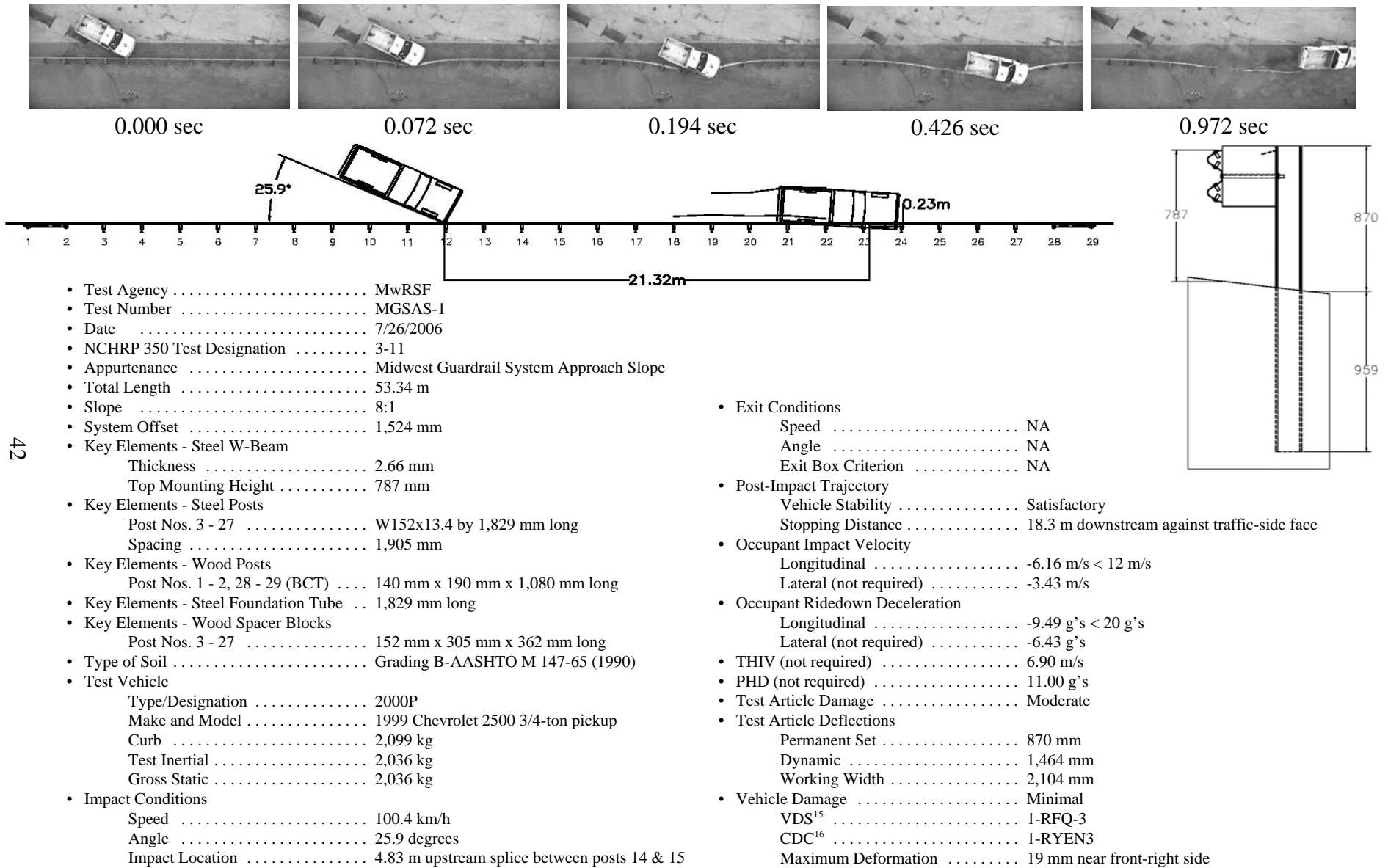

Figure 20. Summary of Test Results and Sequential Photographs, Test No. MGSAS-1



0.000 sec



0.092 sec



0.258 sec



1.524 sec



0.562 sec



0.000 sec



0.092 sec



0.242 sec



1.644 sec



0.666 sec

Figure 21. Additional Sequential Photographs, Test No. MGSAS-1



0.000 sec



0.150 sec



0.280 sec



0.480 sec



0.948 sec

Figure 22. Additional Sequential Photographs, Test No. MGSAS-1



Figure 23. Documentary Photographs, Test No. MGSAS-1



Figure 24. Documentary Photographs, Test No. MGSAS-1

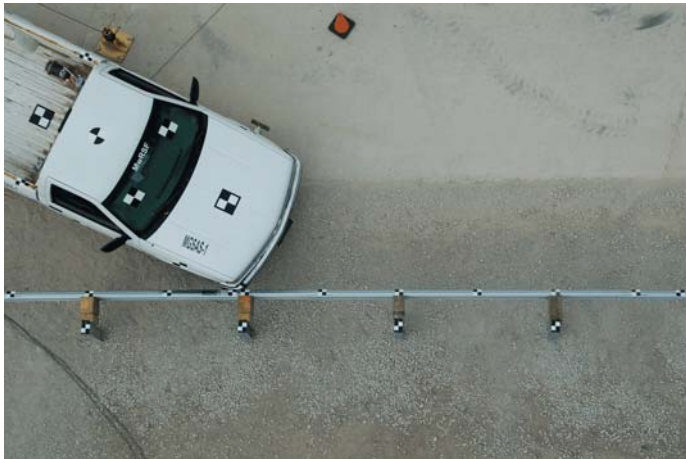

Figure 25. Impact Location, Test No. MGSAS-1



Figure 26. Vehicle Trajectory and Final Position, Test No. MGSAS-1



Figure 27. System Damage, Test No. MGSAS-1



Figure 28. System Damage, Test No. MGSAS-1



Figure 29. Post Nos. 9 through 11 Damage, Test No. MGSAS-1



Figure 30. Post Nos. 12 through 15 Damage, Test No. MGSAS-1



Figure 31. Post Nos. 16 through 20 Damage, Test No. MGSAS-1



Figure 32. Anchorage Damage, Test No. MGSAS-1



Figure 33. Vehicle Damage, Test No. MGSAS-1



Figure 34. Vehicle Damage, Test No. MGSAS-1



Figure 35. Occupant Compartment Damage, Test No. MGSAS-1

8 FULL-SCALE CRASH TEST NO. 2

8.1 Test MGSAS-2

The 912-kg (2,011-lb) small car impacted the MGS, placed 1.5 m (5 ft) down from the slope break point, at a speed of 99.6 km/h (61.9 mph) and at an angle of 21.6 degrees. A summary of the test results and sequential photographs are shown in Figure 36. The summary of the test results and sequential photographs in English units are shown in Appendix B. Additional sequential photographs are shown in Figures 37 and 38. Documentary photographs are shown in Figures 39 and 40.

8.2 Test Description

Initial vehicle impact was to occur between post nos. 13 and 14, or 1.46 m (4 ft - 9.5 in.) upstream from the centerline of the splice between post nos. 14 and 15, as shown in Figure 10 and 41. Actual vehicle impact occurred 1.5 m (4 ft - 11 in.) upstream from the centerline of the splice between post nos. 14 and 15. At 0.014 sec, post no. 14 deflected. At 0.028 sec, post nos. 13 and 15 deflected. At 0.034 sec, the left-front corner of the bumper separated from the hood. At 0.056 sec, post no. 16 deflected. At 0.080 sec, the right-front corner of the hood protruded over the rail. At 0.082 sec, the vehicle began to redirect. At 0.098 sec, post no. 17 deflected. At 0.104 sec, the right-front tire snagged under the rail. At 0.132 sec, post no. 18 deflected. At 0.152 sec, the vehicle became parallel to the system, with a velocity of 84.8 km/h (52.7 mph). At 0.184 sec, the blockout at post no. 16 twisted as the right-front tire contacted it. At 0.248 sec, the front end of the vehicle exited the system. At 0.300 sec, the rail reached its maximum deflection and began to rebound. At 0.378 sec, the right-front tire was severely bent. At 0.390 sec, the vehicle exited the system at an angle of 8.2 degrees and a resultant velocity of 79.1 km/h (49.1 mph). At 0.504 sec, the vehicle

traversed away from the system. The vehicle came to rest 64.99 m (213 ft - 2.5 in.) downstream of impact and 8.56 m (28 ft - 1 in.) laterally away from the traffic-side face of the guardrail system. The trajectory and final position of the small car are shown in Figures 36 and 42.

8.3 Barrier Damage

Damage to the barrier was moderate, as shown in Figures 43 through 46. Barrier damage consisted of deformed guardrail posts, contact marks on a guardrail section and posts, and deformed W-beam rail. The length of vehicle contact along the system was approximately 6.0 m (19 ft - 8 in.), which spanned from 1,359 mm (53.5 in.) downstream from the centerline of post no. 13 through 267 mm (10.5 in.) upstream from the centerline of post no. 17.

Contact marks, along with moderate deformation and flattening, occurred between post nos. 13 and 17. Buckling of the guardrail occurred at post nos. 15 and 16 and at the midspan between post nos. 15 and 16. The W-beam remained attached to all of the posts. No significant guardrail damage occurred upstream of post no. 13 nor downstream of post no. 17.

Steel post nos. 13 through 17 rotated backward. Steel post nos. 3 through 13 encountered minor twisting. Contact marks were found on the blockouts at post nos. 14 and 15. The blockout at post no. 16 was twisted upstream to an angle of 45 degrees. The upstream anchor moved 12.7 mm (0.5 in.) longitudinally. All four wood BCT posts remained undamaged.

The permanent set of the barrier system is shown in Figure 43. The maximum lateral permanent set rail and post deflections were 372 mm (14.625 in.) at the centerline of post no. 15 and 349 mm (13.75 in.) at post no. 15, respectively, as measured in the field. The maximum lateral dynamic rail and post deflections were 635 mm (25 in.) at the centerline of post no. 15 and 635 mm (25 in.) at post no. 15, respectively, as determined from high-speed digital video analysis. The

working width of the system was found to be 1,177 mm (46.3 in.).

8.4 Vehicle Damage

Exterior vehicle damage was minimal, as shown in Figures 47 and 48. Occupant compartment deformations to the right side and center of the floorboard were judged insufficient to cause serious injury to the vehicle occupants. Complete occupant compartment deformations and the corresponding locations are provided in Appendix E.

Damage was concentrated on the front-right corner of the vehicle. The right-side door separated from the right-front quarter panel. The top of the right-side door was ajar. The right-front quarter panel crushed inward toward the engine compartment. The right-side headlight was intact, but the glass and the turn signal were fractured. The bumper shifted toward the left and was separated from the left mount. Scratches were found along the entire right side of the vehicle and the right corner of the front and back bumpers. The right-front tire encountered contact marks. The right-side control arm was deformed downward. The roof, hood, left side, and rear of the vehicle, and all window glass remained undamaged.

8.5 Occupant Risk Values

The longitudinal and lateral occupant impact velocities were determined to be -3.75 m/s (-12.30 ft/s) and -5.31 m/s (-17.41 m/s), respectively. The maximum 0.010-sec average occupant ridedown decelerations in the longitudinal and lateral directions were -4.03 g's and -9.65 g's, respectively. It is noted that the occupant impact velocities (OIVs) and occupant ridedown decelerations (ORDs) were within the suggested limits provided in NCHRP Report No. 350. The THIV and PHD values were determined to be 5.93 m/s (19.46 ft/s) and 9.68 g's, respectively. The results of the occupant risk, as determined from the accelerometer data, are summarized in Figure

36. Results are shown graphically in Appendix F. The results from the rate transducer are shown graphically in Appendix F.

8.6 Discussion

The analysis of the test results for test no. MGSAS-2 showed that the MGS placed 1,524 mm (5 ft) down from the slope break point of an 8:1 slope adequately contained and redirected 820C the vehicle with controlled lateral displacements of the barrier system. There were no detached elements nor fragments which showed potential for penetrating the occupant compartment nor presented undue hazard to other traffic. Deformations of, or intrusion into, the occupant compartment that could have caused serious injury did not occur. The test vehicle did not penetrate nor ride over the guardrail system and remained upright during and after the collision. Vehicle roll, pitch, and yaw angular displacements were noted, but they were deemed acceptable because they did not adversely influence occupant risk safety criteria nor cause rollover. After collision, the vehicle's trajectory revealed minimal intrusion into adjacent traffic lanes. In addition, the vehicle's exit angle was less than 60 percent of the impact angle. Therefore, test no. MGSAS-2 conducted on the MGS placed 1,524 mm (5 ft) down from the slope break point of an 8:1 slope was determined to be acceptable according to the TL-3 safety performance criteria of test designation no. 3-10 found in NCHRP Report No. 350.



0.000 sec

0.040 sec

0.100 sec

0.206 sec

0.372 sec

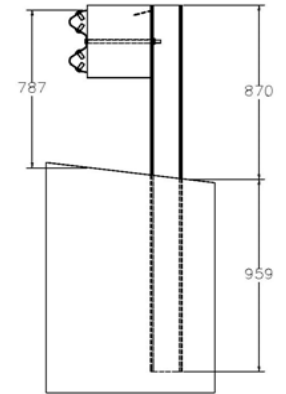
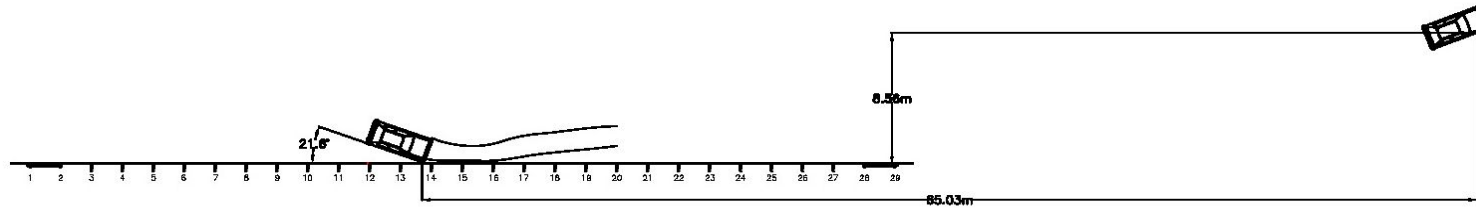

62

- Test Agency MwRSF
- Test Number MGSAS-2
- Date 9/6/2006
- NCHRP 350 Test Designation 3-10
- Appurtenance Midwest Guardrail System Approach Slope
- Total Length 53.34 m
- Slope 8:1
- System Offset 1,524 mm
- Key Elements - Steel W-Beam
 - Thickness 2.66 mm
 - Top Mounting Height 787 mm
- Key Elements - Steel Posts
 - Post Nos. 3 - 27 W152x13.4 by 1,829 mm long
 - Spacing 1,905 mm
- Key Elements - Wood Posts
 - Post Nos. 1 - 2, 28 - 29 (BCT) 140 mm x 190 mm by 1,080 mm long
- Key Elements - Steel Foundation Tube 1,829 mm long
- Key Elements - Wood Spacer Blocks
 - Post Nos. 3 - 27 152 mm x 305 mm by 362 mm long
- Type of Soil Grading B-AASHTO M 147-65 (1990)
- Test Vehicle
 - Type/Designation 820C
 - Make and Model 2000 Geo Metro
 - Curb 836 kg
 - Test Inertial 837 kg
 - Gross Static 912 kg
- Impact Conditions
 - Speed 99.6 km/h
 - Angle 21.6 degrees
 - Impact Location 1.5 m upstream splice between posts 14 & 15
- Exit Conditions
 - Speed 79.1 km/h
 - Angle 8.2 degrees
 - Exit Box Criterion Pass
- Post-Impact Trajectory
 - Vehicle Stability Satisfactory
 - Stopping Distance 65.03 m downstream
8.56 m away from traffic-side face
- Occupant Impact Velocity
 - Longitudinal -3.75 m/s < 12 m/s
 - Lateral -5.31 m/s < 12 m/s
- Occupant Ridedown Deceleration
 - Longitudinal -4.03 g's < 20 g's
 - Lateral -9.65 g's < 20 g's
- THIV (not required) 5.93 m/s
- PHD (not required) 9.68 g's
- Test Article Damage Moderate
- Test Article Deflections
 - Permanent Set 372 mm
 - Dynamic 635 mm
 - Working Width 1,177 mm
- Vehicle Damage Minimal
 - VDS¹⁵ 1-RFQ-3
 - CDC¹⁶ 1-RYEN5
 - Maximum Deformation NA

Figure 36. Summary of Test Results and Sequential Photographs, Test No. MGSAS-2



0.000 sec



0.082 sec



0.156 sec



0.248 sec



0.378 sec



0.000 sec



0.052 sec



0.120 sec



0.300 sec



0.390 sec

Figure 37. Additional Sequential Photographs, Test No. MGSAS-2



0.000 sec



0.036 sec



0.104 sec



0.238 sec



0.708 sec

Figure 38. Additional Sequential Photographs, Test No. MGSAS-2



Figure 39. Documentary Photographs, Test No. MGSAS-2



Figure 40. Documentary Photographs, Test No. MGSAS-2

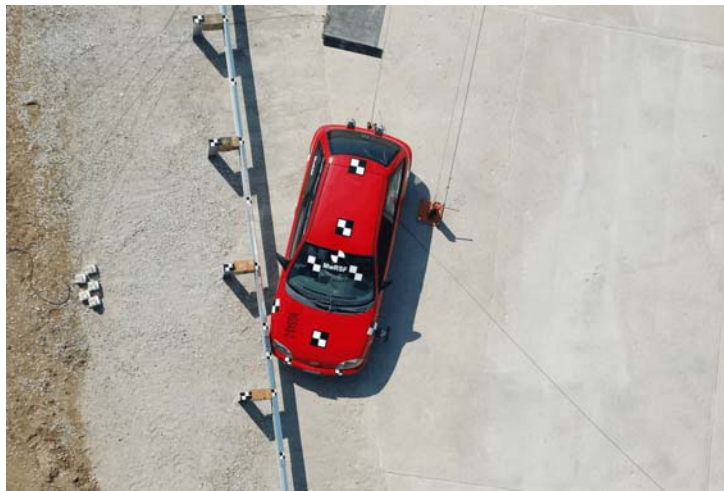
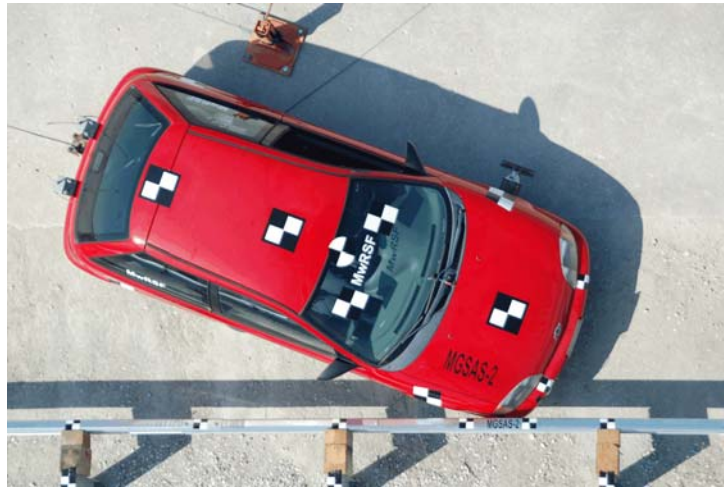

Figure 41. Impact Location, Test No. MGSAS-2



Figure 42. Vehicle Trajectory and Final Position, Test No. MGSAS-2



Figure 43. System Damage, Test No. MGSAS-2



Figure 44. Post Nos. 14 through 16 Damage, Test No. MGSAS-2



Figure 45. Post Nos. 13 and 17 Damage, Test No. MGSAS-2



Figure 46. Upstream Anchorage Damage, Test No. MGSAS-2



Figure 47. Vehicle Damage, Test No. MGSAS-2



Figure 48. Vehicle Damage, Test No. MGSAS-2

9 SUMMARY, CONCLUSIONS, AND RECOMMENDATIONS

The MGS placed on an 8:1 slope, 1,524 mm (5 ft) down from the slope break point, was subjected to full-scale vehicle crash testing. Two full-scale vehicle crash tests were performed according to the TL-3 safety performance criteria presented in NCHRP Report No. 350. The test results indicate that this design is suitable for use on Federal-aid highways. However, any significant modifications made to the design would require additional analysis and can only be verified through the use of full-scale crash testing. A summary of the safety performance evaluation for both tests is provided in Table 4.

The first crash test, test no. MGSAS-1, was performed with a $\frac{3}{4}$ -ton pickup truck. The truck was safely contained and redirected with minimal barrier deflections and damage. The truck came to rest against the guardrail and did not intrude into adjacent traffic lanes. There was minimal damage to the vehicle, and it was determined to not pose any significant risk to the occupants of the vehicle. Therefore, test no. MGSAS-1 was determined to be acceptable according to the test designation 3-11 safety performance criteria presented in NCHRP Report No. 350.

The second crash test, test no. MGSAS-2, was performed with a small car. The vehicle was safely contained and redirected with minimal barrier deflections and damage. The vehicle showed minimal intrusion into adjacent traffic lanes, and it was determined to not pose any significant risk to the occupants of the vehicle. Therefore, test no. MGSAS-2 was determined to be acceptable according to the test designation 3-10 safety performance criteria presented in NCHRP Report No. 350.

Due to the fact that the suspension does not exist in the small car DYNA model, it was difficult to determine the critical location of the MGS on an 8:1 slope. However, when following

the bumper trajectory of the 820C vehicle, the bumper has been shown to be above the neutral position within 2.4 m (8 ft) of the slope breakpoint of an 8:1 slope. Thus, the critical location of the MGS on an 8:1 slope for the 2000P impact was thought to be a reasonable CIP location for the small car test. Potential vehicle underride was not believed to be a concern since the MGS previously has been successfully tested at the maximum top mounting height of 813 mm (32 in.). Therefore, the MGS with a top mounting height of 787 mm (31 in.) may be placed on an 8:1 slope. However standard W-beam guardrail with a top mounting height of 686 mm (27 in.) should not be placed on an embankment with a slope greater than 10:1 due to the unsatisfactory performance of standard W-beam guardrail when tested on a slope (2) as currently provided on page 5-31 of the Roadside Design Guide. Finally, as stated in the Roadside Design Guide, "...Caution should be taken when considering installations on slopes as steep as IV:6H..." (3, pp.5-31).

Table 4. Summary of Safety Performance Evaluation Results

Evaluation Factors	Evaluation Criteria	Test MGSAS-1	Test MGSAS-2
Structural Adequacy	A. Test article should contain and redirect the vehicle; the vehicle should not penetrate, underride, or override the installation although controlled lateral deflection of the test article is acceptable.	S	S
Occupant Risk	D. Detached elements, fragments or other debris from the test article should not penetrate or show potential for penetrating the occupant compartment, or present an undue hazard to other traffic, pedestrians, or personnel in a work zone. Deformations of, or intrusions into, the occupant compartment that could cause serious injuries should not be permitted.	S	S
	F. The vehicle should remain upright during and after collision although moderate roll, pitching, and yawing are acceptable.	S	S
	H. Longitudinal and lateral occupant impact velocities should fall below the preferred value of 9 m/s (29.53 ft/s), or at least below the maximum allowable value of 12 m/s (39.37 ft/s).	NA	S
	I. Longitudinal and lateral occupant ridedown accelerations should fall below the preferred value of 15 g's, or at least below the maximum allowable value of 20 g's.	NA	S
Vehicle Trajectory	K. After collision it is preferable that the vehicle's trajectory not intrude into adjacent traffic lanes.	S	S
	L. The occupant impact velocity in the longitudinal direction should not exceed 12 m/sec (39.37 ft/s), and the occupant ridedown acceleration in the longitudinal direction should not exceed 20 g's.	S	NA
	M. The exit angle from the test article preferably should be less than 60 percent of the test impact angle measured at the time of vehicle loss of contact with the test device.	S	S

S - Satisfactory
 U - Unsatisfactory
 NA - Not Applicable

10 REFERENCES

1. Ross, H.E., Jr., Sicking, D.L., *Development of Guidelines for Placement of Longitudinal Barriers on Slopes - Volume I - Executive Summary*, Report No. 3659-1, submitted to Federal Highway Administration, Performed by Texas Transportation Institute, May 1983.
2. Ross, H.E., Jr., Smith, D.G., Sicking, D.L., Hall, P.R., *Development of Guidelines for Placement of Longitudinal Barriers on Slopes - Volume II - Full-Scale Crash Tests*, Report 3659-2, submitted to Federal Highway Administration, Performed by Texas Transportation Institute, May 1983.
3. *Roadside Design Guide*, American Association of State Highway and Transportation Officials (AASHTO), Washington, D.C., 2002.
4. Ross, H.E., Sicking, D.L., Zimmer, R.A., and Michie, J.D., *Recommended Procedures for the Safety Performance Evaluation of Highway Features*, National Cooperative Research Program (NCHRP) Report No. 350, Transportation Research Board, Washington, D.C., 1993.
5. *Guide for Selecting, Locating, and Designing Traffic Barrier*, American Association of State Highway and Transportation Officials, Washington D.C., 1977.
6. Stout, D., Hughes, W., McGee, H., *Traffic Barriers on Curves, Curbs, and Slopes*, Report No. FHWA-RD-93-082, submitted to the Office of Safety and Traffic Operations R&D, Federal Highway Administration, Performed by Applied Technology and Engineering Division, ENSCO, Inc., Springfield, VA, 1993.
7. *Guide Specifications for Bridge Railings*, American Association of State Highway and Transportation Officials, Washington D.C., 1989.
8. Polivka, K.A., Faller, R.K., Sicking, D.L., Rohde, J.R., Holloway, J.C., Keller, E.A., *Development of a W-Beam Guardrail System for use on a 2:1 Slope*, Final Report to Midwest States' Regional Pooled Fund Program, Transportation Research Report No. TRP-03-99-00, Midwest Roadside Safety Facility, University of Nebraska-Lincoln, October 16, 2000.
9. Polivka, K.A., Sicking, D.L., Faller, R.K., and Rohde, J.R., *A W-Beam Guardrail Adjacent to a Slope*, Paper No. 01-0343, Transportation Research Record No. 1743, Journal of the Transportation Research Board, Transportation Research Board, Washington, D.C., January 2001.

10. Polivka, K.A., Faller, R.K., Sicking, D.L., and Bielenberg, R.W., *Midwest Guardrail System Adjacent to a 2:1 Slope*, Paper No. 08-3076, Accepted for Publication at the Annual Meeting of the Transportation Research Board, TRB AFB20 Committee on Roadside Safety Design, Transportation Research Board, Washington D.C., January 2008.
11. Wiebelhaus, M.J., Lechtenberg, K.A., Faller, R.K., Sicking, D.L., Bielenberg, R.W., Reid, J.D., Rohde, J.R., Dey, G., *Development and Evaluation of the Midwest Guardrail System (MGS) Placed Adjacent to a 2:1 Slope*, Draft Report to Midwest States' Regional Pooled Fund Program, Transportation Research Report No. TRP-03-185-08, Midwest Roadside Safety Facility, University of Nebraska-Lincoln, In Progress.
12. Sicking, D.L., Mak, K.K., Rohde, J.R., and Reid, J.D., *Recommended Procedures for the Safety Performance Evaluation of Highway Features, Draft Report*, Submitted to National Cooperative Highway Research Program, Project 22-14(2) Panel, Prepared by the Midwest Roadside Safety Facility, University of Nebraska-Lincoln, January 10, 2008.
13. Hinch, J., Yang, T.L., and Owings, R., *Guidance Systems for Vehicle Testing*, ENSCO, Inc., Springfield, VA, 1986.
14. Hallquist, J.O., *LS-DYNA Keyword User's Manual*, Livermore Software Technology Corporation, California, 1997.
15. *Vehicle Damage Scale for Traffic Investigators*, Second Edition, Technical Bulletin No. 1, Traffic Accident Data (TAD) Project, National Safety Council, Chicago, Illinois, 1971.
16. *Collision Deformation Classification - Recommended Practice J224 March 1980*, Handbook Volume 4, Society of Automotive Engineers (SAE), Warrendale, Pennsylvania, 1985.

11 APPENDICES

APPENDIX A

MGS Approach Slope Design Details, English Units

Figure A-1. System Layout (English)

Figure A-2. End Rail and Splice Details (English)

Figure A-3. Post Nos. 3 through 27 Details (English)

Figure A-4. Anchor Post Details (English)

Figure A-5. BCT Cable Anchor Details (English)

Figure A-6. Ground Strut and Anchor Bracket Details (English)

Figure A-7. Rail Section Details (English)

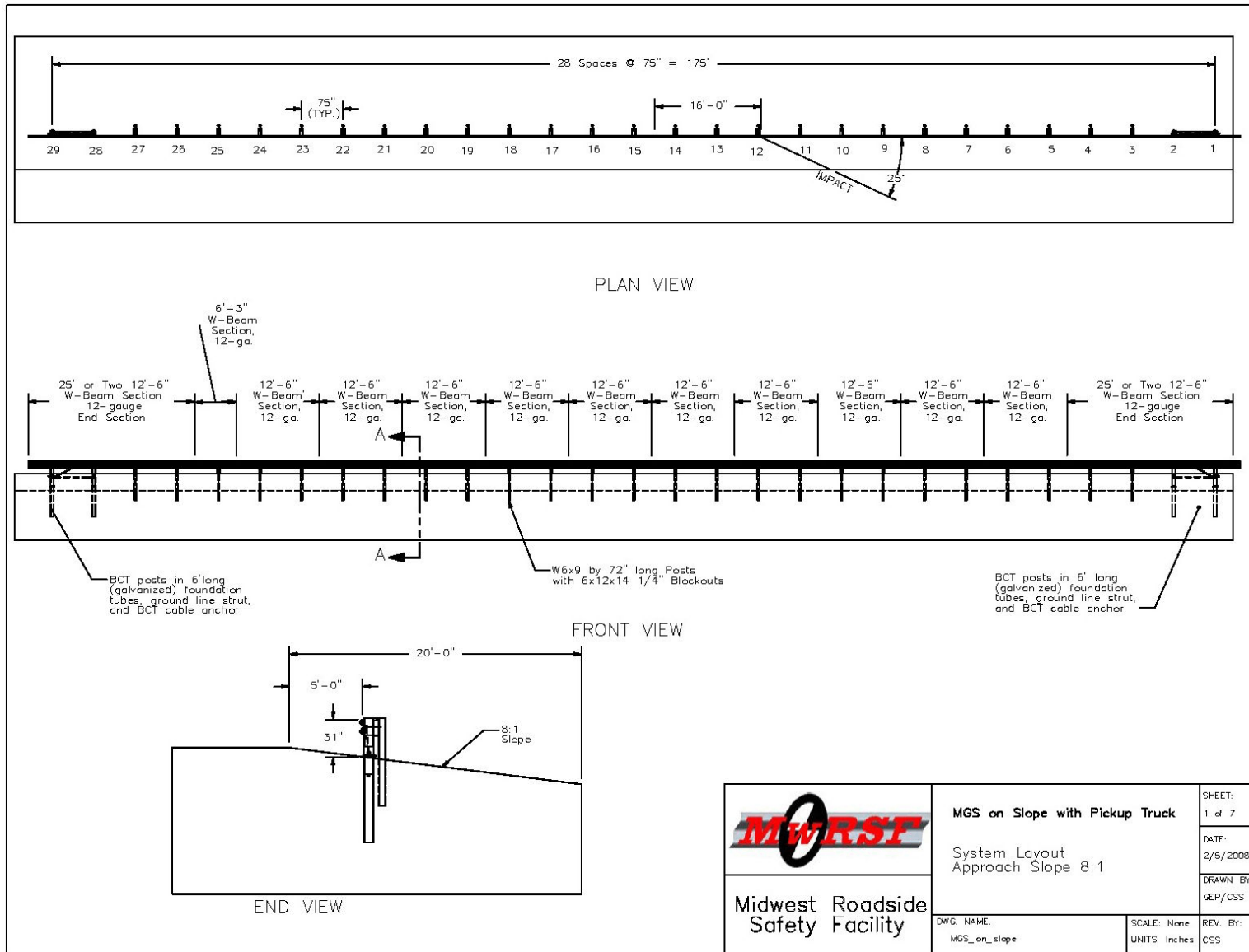

Figure A-1. System Layout (English)

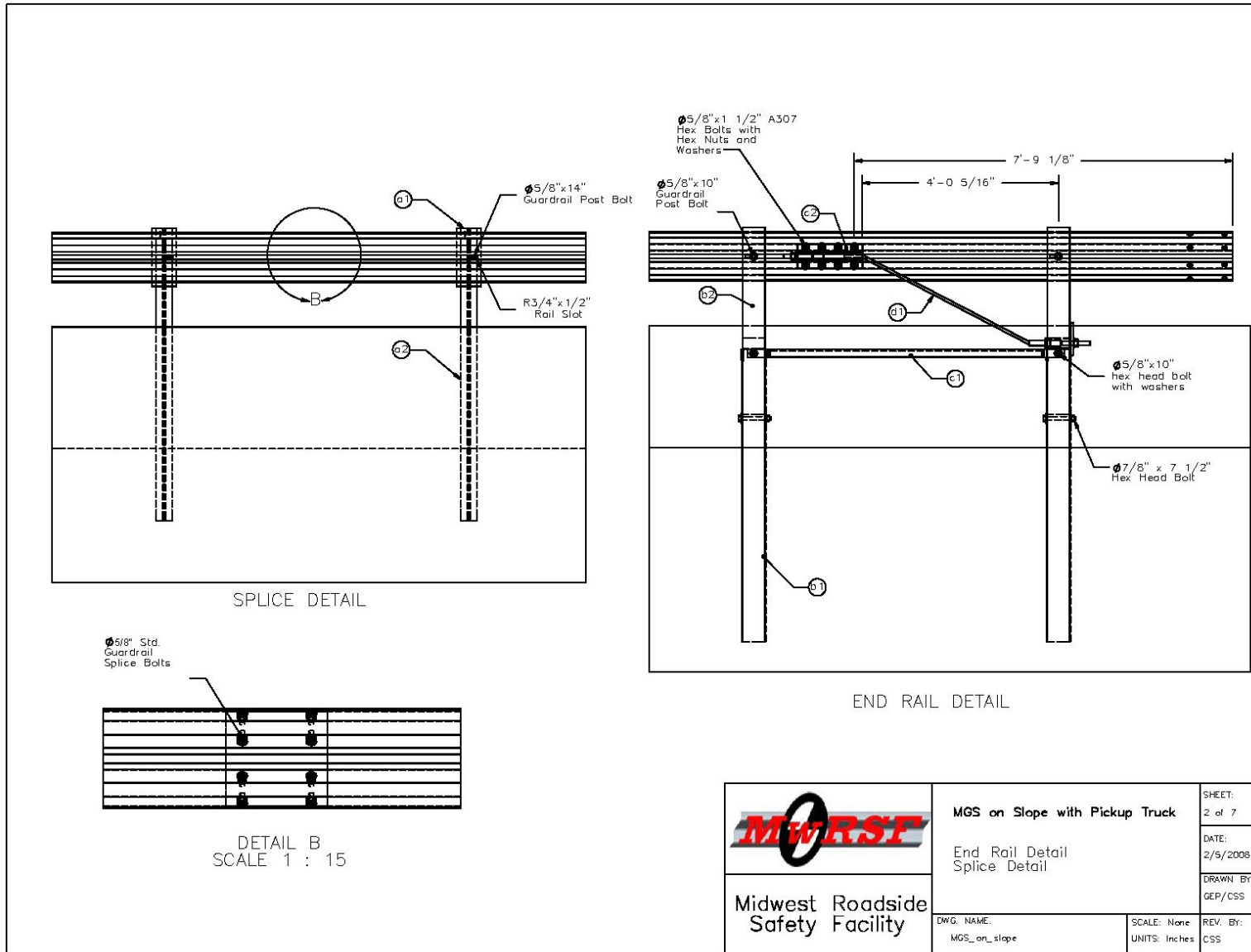

Figure A-2. End Rail and Splice Details (English)

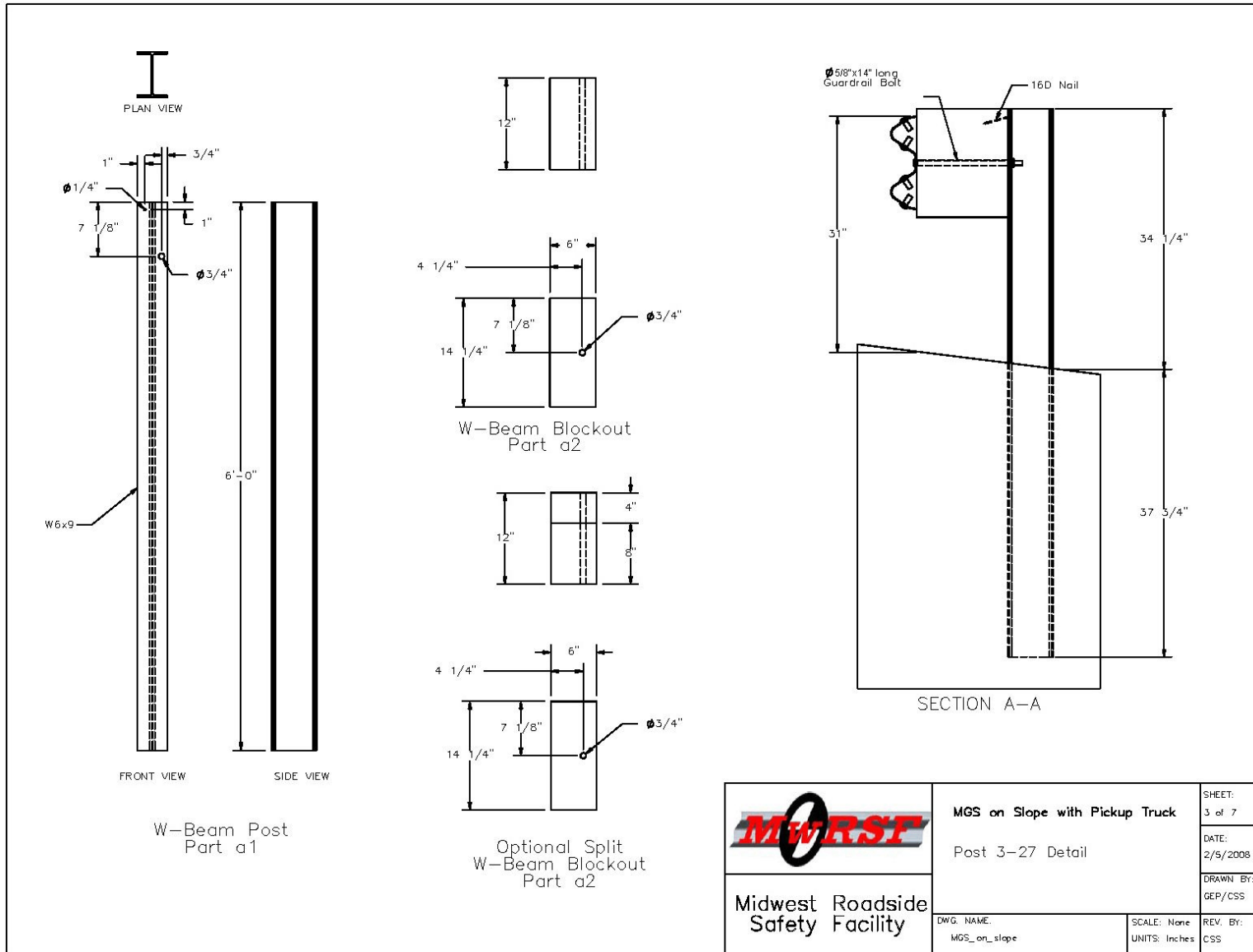

Figure A-3. Post Nos. 3 through 27 Details (English)

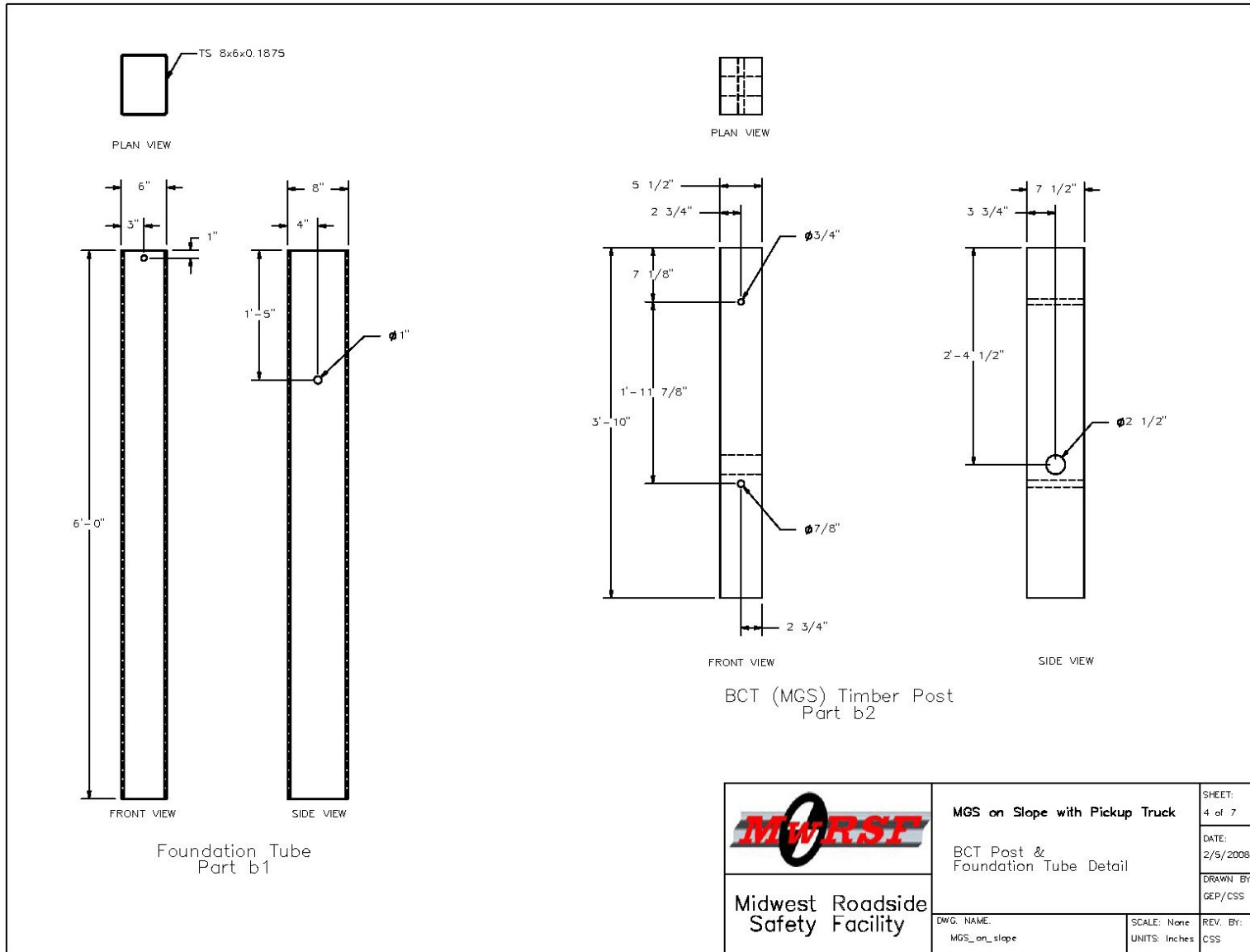

Figure A-4. Anchor Post Details (English)

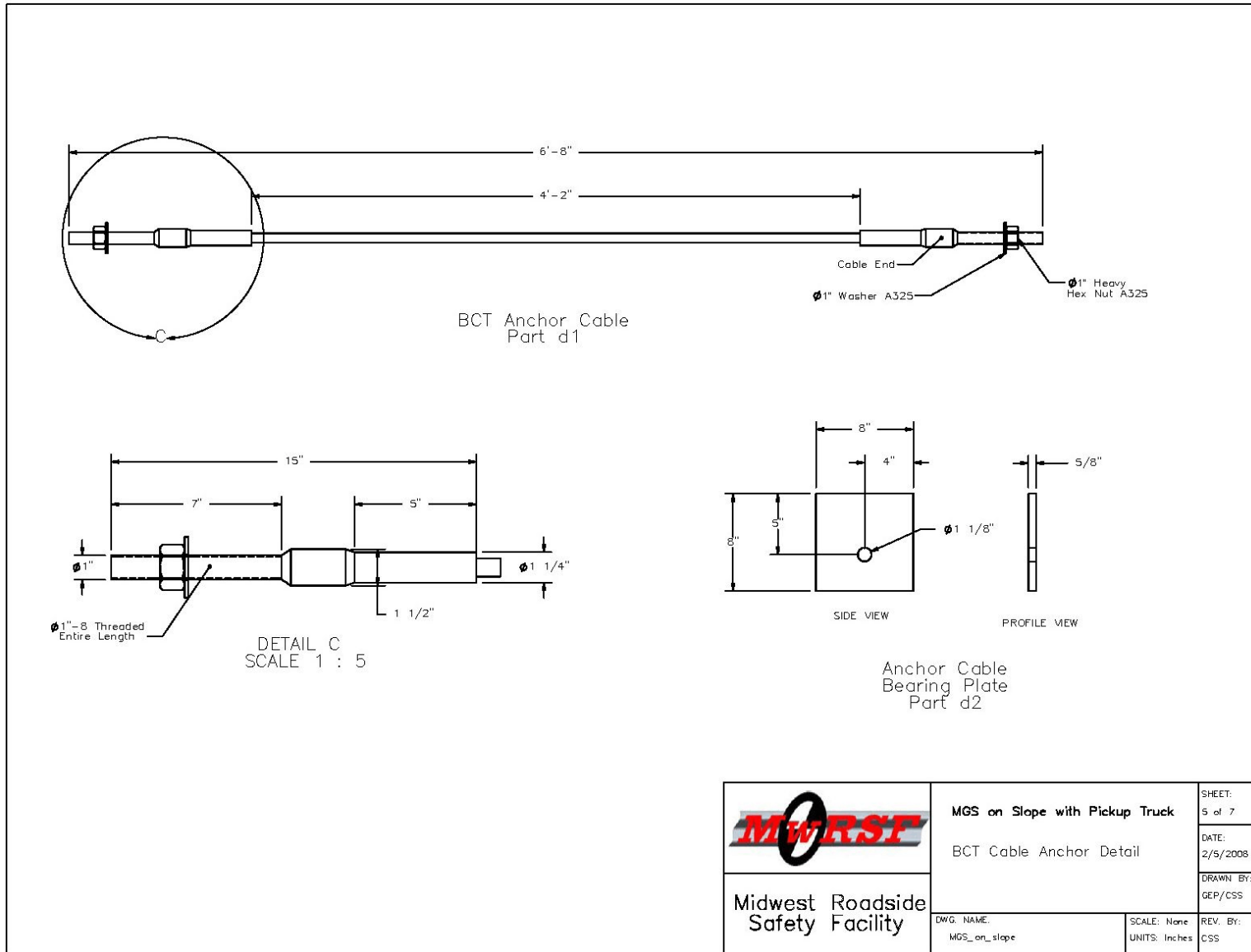

Figure A-5. BCT Cable Anchor Details (English)

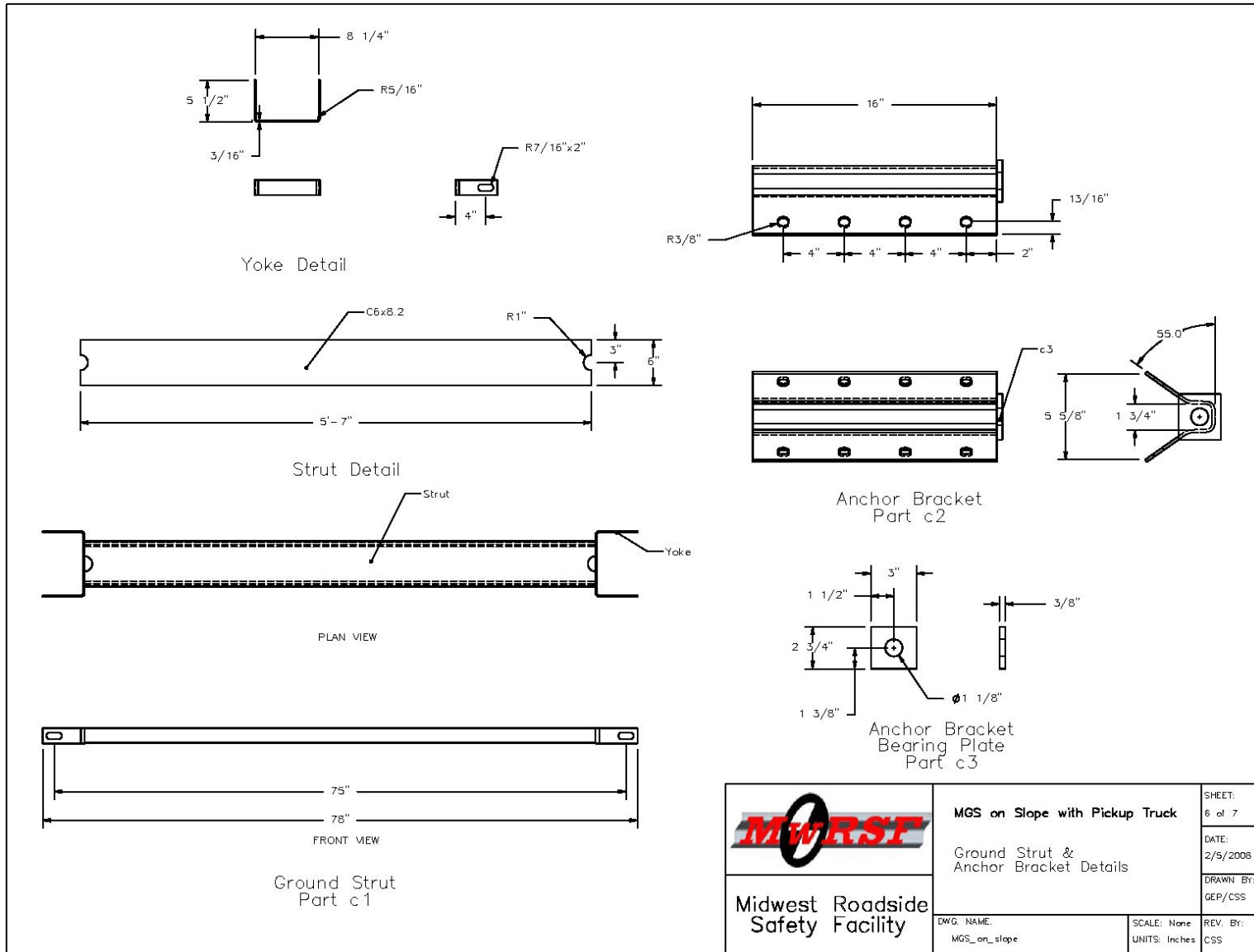

Figure A-6. Ground Strut and Anchor Bracket Details (English)

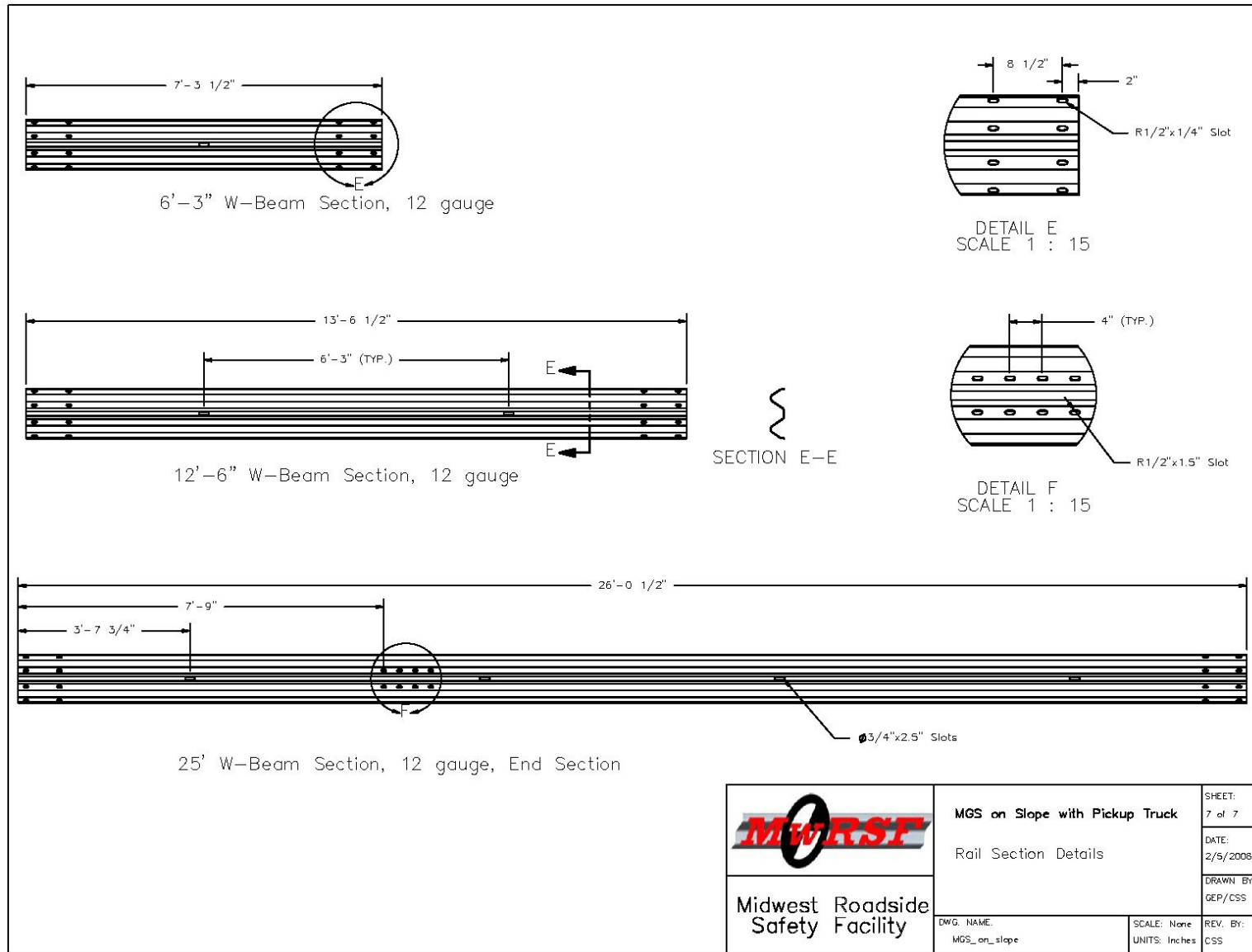

Figure A-7. Rail Section Details

APPENDIX B

Test Summary Sheet in English Units

Figure B-1. Summary of Test Results and Sequential Photographs (English), Test No. MGSAS-1

Figure B-2. Summary of Test Results and Sequential Photographs (English), Test No. MGSAS-2



0.000 sec

0.072 sec

0.194 sec

0.426 sec

0.972 sec

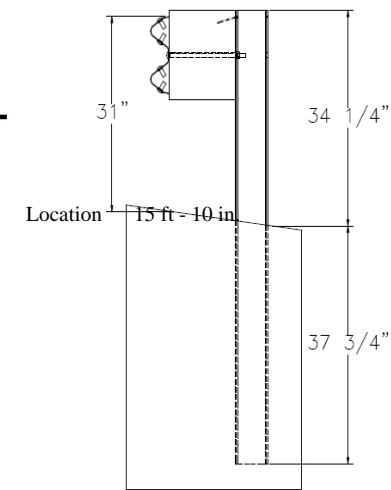
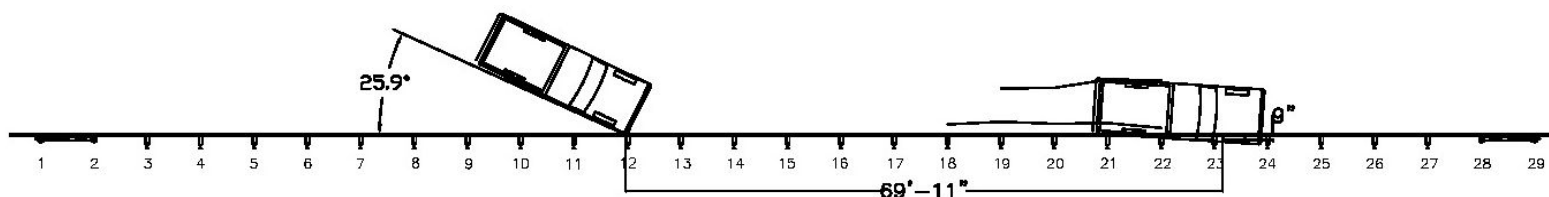

upstream splice between posts 14&15

06

- Test Agency MwRSF
- Test Number MGSAS-1
- Date 7/26/2006
- NCHRP 350 Test Designation 3-11
- Appurtenance Midwest Guardrail System Approach Slope
- Total Length 175 ft
- Slope 8:1
- System Offset 5 ft
- Key Elements - Steel W-Beam
 - Thickness 12 gauge
 - Top Mounting Height 31 in.
- Key Elements - Steel Posts
 - Post Nos. 3 - 27 W6x9 by 6 ft long
 - Spacing 75 in.
- Key Elements - Wood Posts
 - Post Nos. 1 - 2, 28 - 29 (BCT) ... 5.5 in. x 7.5 in. by 42.5 in. long
- Key Elements - Steel Foundation Tube . 6 ft long
- Key Elements - Wood Spacer Blocks
 - Post Nos. 3 - 27 6 in. x 12 in. by 14.25 in. long
- Type of Soil Grading B-AASHTO M 147-65 (1990)
- Test Vehicle
 - Type/Designation 2000P
 - Make and Model 1999 Chevrolet 2500 3/4-ton pickup
 - Curb 4,627 lbs
 - Test Inertial 4,489 lbs
 - Gross Static 4,489 lbs
- Impact Conditions
 - Speed 62.4 mph
 - Angle 25.9 degrees
 - Impact

- Exit Conditions
 - Speed NA
 - Angle NA
 - Exit Box Criterion NA
- Post-Impact Trajectory
 - Vehicle Stability Satisfactory
 - Stopping Distance 60 ft - 1.5 in. downstream against traffic-side face
- Occupant Impact Velocity
 - Longitudinal -20.2 ft/s < 39.4 ft/s
 - Lateral (not required) -11.3 ft/s
- Occupant Ridedown Deceleration
 - Longitudinal -9.49 g's < 20 g's
 - Lateral (not required) -6.43 g's
- THIV (not required) 22.60 ft/s
- PHD (not required) 11.00 s
- Test Article Damage Moderate
- Test Article Deflections
 - Permanent Set 34.25 in.
 - Dynamic 57.6 in.
 - Working Width 82.8 in.
- Vehicle Damage Minimal
 - VDS¹⁵ 1-RFQ-3
 - CDC¹⁶ 1-RYEN3
 - Maximum Deformation 0.75 in. near front right side

Figure B-1. Summary of Test Results and Sequential Photographs (English), Test No. MGSAS-1

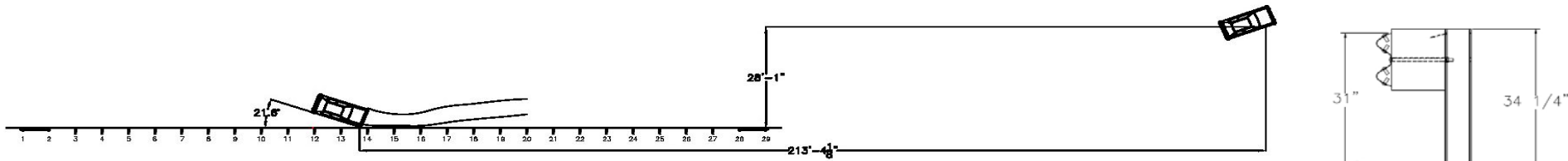
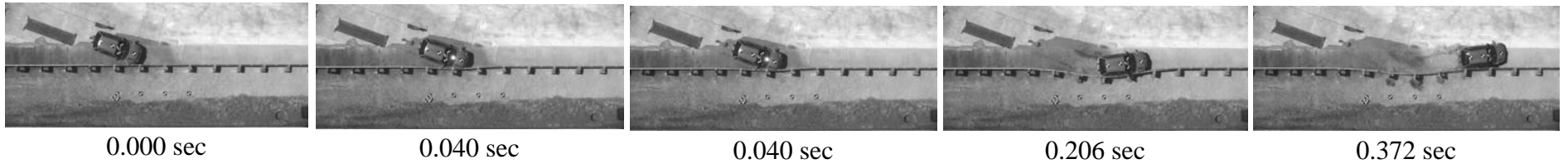

I 6

- Test Agency MwRSF
- Test Number MGSAS-2
- Date 9/6/2006
- NCHRP 350 Test Designation 3-10
- Appurtenance Midwest Guardrail System Approach Slope
- Total Length 175 ft
- Slope 8:1
- System Offset 5 ft
- Key Elements - Steel W-Beam
 - Thickness 12 gauge
 - Top Mounting Height 31 in.
- Key Elements - Steel Posts
 - Post Nos. 3 - 27 W6x9 by 6 ft long
 - Spacing 75 in.
- Key Elements - Wood Posts
 - Post Nos. 1 - 2, 28 - 29 (BCT) 5.5 in. x 7.5 in. by 42.5 in. long
- Key Elements - Steel Foundation Tube 6-ft long
- Key Elements - Wood Spacer Blocks
 - Post Nos. 3 - 27 6 in. x 12 in. by 14.25 in. long
- Type of Soil Grading B-AASHTO M 147-65 (1990)
- Test Vehicle
 - Type/Designation 820C
 - Make and Model 2000 Chevrolet Metro
 - Curb 1,843 lbs
 - Test Inertial 1,845 lbs
 - Gross Static 2,011 lbs
- Impact Conditions
 - Speed 61.9 mph
 - Angle 21.6 degrees
 - Impact Location 4 ft - 11 in. US splice between posts 14 & 15

- Exit Conditions
 - Speed 49.2 mph
 - Angle 8.2 degrees
 - Exit Box Criterion Pass
- Post-Impact Trajectory
 - Vehicle Stability Satisfactory
 - Stopping Distance 213 ft - 4.125 in. downstream
 - 28 ft - 1 in. traffic-side face
- Occupant Impact Velocity
 - Longitudinal -12.3 ft/s < 39.4 ft/s
 - Lateral -17.4 ft/s < 39.4 ft/s
- Occupant Ridedown Deceleration
 - Longitudinal -4.03 g's < 20 g's
 - Lateral -9.65 g's < 20 g's
- THIV (not required) 19.5 ft/s
- PHD (not required) 9.68 g's
- Test Article Damage Moderate
- Test Article Deflections
 - Permanent Set 14.625 in.
 - Dynamic 25 in.
 - Working Width 46.3 in.
- Vehicle Damage Minimal
 - VDS¹⁵ 1-RFQ-3
 - CDC¹⁶ 1-RYEN5
 - Maximum Deformation NA

Figure B-2. Summary of Test Results and Sequential Photographs (English), Test No. MGSAS-2

APPENDIX C

Occupant Compartment Deformation, Test No. MGSAS-1

Figure C-1. Occupant Compartment Deformation Data - Set 1, Test No. MGSAS-1

Figure C-2. Occupant Compartment Deformation Data - Set 2, Test No. MGSAS-1

Figure C-3. Occupant Compartment Deformation Index (OCDI), Test No. MGSAS-1

VEHICLE PRE/POST CRUSH INFO

Set-1

TEST: MGSAS-1
 VEHICLE: 1999 Chevy C2500

Note: If impact is on driver side need to enter negative number for Y

POINT	X	Y	Z	X'	Y'	Z'	DEL X	DEL Y	DEL Z
1	58.25	16.5	-1.75	58.5	16	-1.75	0.25	-0.5	0
2	58.5	22.5	-2	58.5	21.75	-2.25	0	-0.75	-0.25
3	57.5	28.25	-1	57.5	27.5	-1	0	-0.75	0
4	52.5	1.5	0	52.5	1.5	0	0	0	0
5	52.25	6.5	-0.25	52.25	6.5	0	0	0	0.25
6	54.5	12.25	-4.75	54.75	12	-4.75	0.25	-0.25	0
7	54.5	17	-4.5	54.75	17	-4.75	0.25	0	-0.25
8	54.75	23.25	-4.75	54.75	23	-5	0	-0.25	-0.25
9	54.75	28.5	-4.25	54.75	28	-4.5	0	-0.5	-0.25
10	48.25	6.5	-2.25	48.5	6.5	-1.75	0	0	0.5
11	48	12	-8	48	12	-7.75	0	0	0.25
12	48.5	18.25	-8	48.5	18	-7.75	0	-0.25	0.25
13	47.5	24	-7.5	47.5	24	-7.75	0	0	-0.25
14	47.75	29.25	-7.5	48	29.25	-7.5	0.25	0	0
15	43.5	6.5	-3.25	43.5	6.5	-2.75	0	0	0.5
16	43.5	11.5	-8.25	43.5	11.25	-8	0	-0.25	0.25
17	44.5	18.5	-8.5	44.5	18.5	-8.25	0	0	0.25
18	43	24.25	-8.25	43	24	-8.25	0	-0.25	0
19	44	28.75	-8.5	44	28.75	-8.5	0	0	0
20	38.75	6.5	-4.25	38.75	6.5	-3.75	0	0	0.5
21	37.75	11.25	-9	37.75	11	-8.5	0	-0.25	0.5
22	37.75	16.25	-9	37.75	16	-8.75	0	-0.25	0.25
23	37	21.5	-8.75	37	21.5	-8.5	0	0	0.25
24	36.5	26.75	-9	36.75	26.75	-9	0.25	0	0
25	30.25	6.5	-6	30.5	6.5	-5.5	0.25	0	0.5
26	30.25	10.75	-10	30.25	11	-9.5	0	0.25	0.5
27	29.75	16.75	-10	29.5	17	-9.5	-0.25	0.25	0.5
28	30.75	24.75	-9	30.75	25	-8.75	0	0.25	0.25

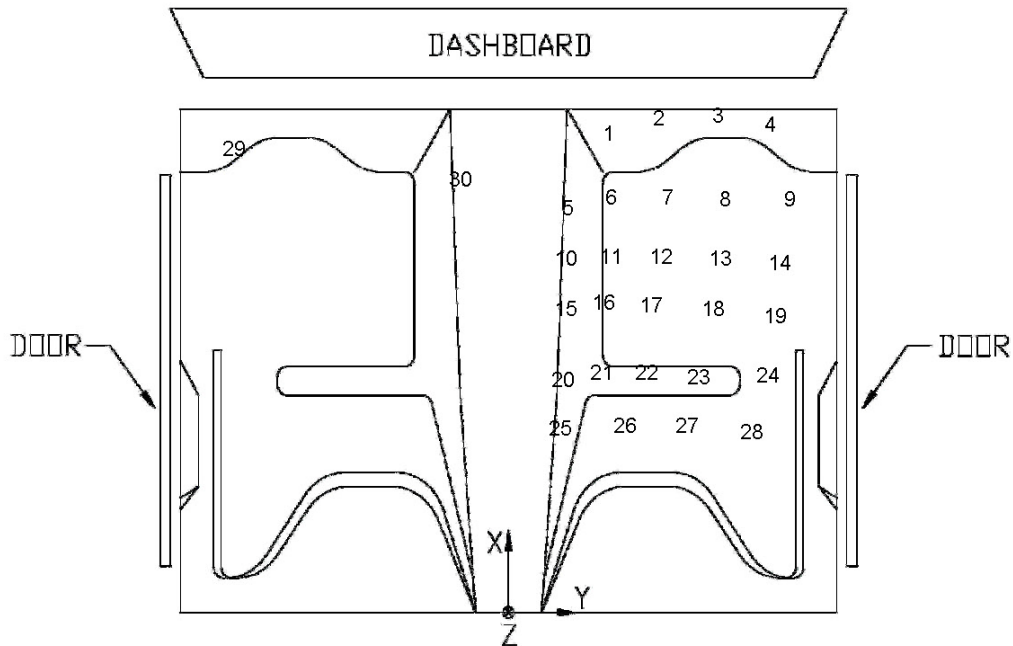

Figure C-1. Occupant Compartment Deformation Data - Set 1, Test No. MGSAS-1

VEHICLE PRE/POST CRUSH INFO

Set-2

TEST: MGSAS-1
 VEHICLE: 1999 Chevy C2500

Note: If Impact is on driver side need to enter negative number for Y

POINT	-6.5			8.5			DEL X	DEL Y	DEL Z
	X	Y	Z	X'	Y'	Z'			
1	51.75	25	-1.5	52	24.5	-1.5	0.25	-0.5	0
2	52	31	-1.75	52	30.25	-1.75	0	-0.75	0
3	51	36.75	-0.25	51	36	-0.25	0	-0.75	0
4	46	10	-0.5	46	10	-0.25	0	0	0.25
5	45.75	15	-0.5	45.75	15	0.25	0	0	0.75
6	48	20.75	-4.75	48.25	20.5	-4.75	0.25	-0.25	0
7	48	25.5	-4.5	48.25	25.5	-4.5	0.25	0	0
8	48.25	31.75	-4.25	48.25	31.5	-4.5	0	-0.25	-0.25
9	48.25	37	-3.5	48.25	36.5	-3.75	0	-0.5	-0.25
10	41.75	15	-2.25	42	15	-2	0	0	0.25
11	41.5	20.5	-7.75	41.5	20.5	-7.5	0	0	0.25
12	42	26.75	-7.5	42	26.5	-7.5	0	-0.25	0
13	41	32.5	-6.75	41	32.5	-7	0	0	-0.25
14	41.25	37.75	-6.5	41.5	37.75	-6.75	0.25	0	-0.25
15	37	15	-3	37	15	-2.75	0	0	0.25
16	37	20	-8	37	19.75	-7.5	0	-0.25	0.5
17	38	27	-7.75	38	27	-7.5	0	0	0.25
18	36.5	32.75	-7	36.5	32.5	-7	0	-0.25	0
19	37.5	37.25	-7	37.5	37.25	-7.25	0	0	-0.25
20	32.25	15	-4	32.25	15	-3.25	0	0	0.75
21	31.25	19.75	-6.25	31.25	19.5	-6	0	-0.25	0.25
22	31.25	24.75	-8.25	31.25	24.5	-8	0	-0.25	0.25
23	30.5	30	-7.75	30.5	30	-7.25	0	0	0.5
24	30	35.25	-7.5	30.25	35.25	-7.5	0.25	0	0
25	23.75	15	-5.25	24	15	-4.75	0.25	0	0.5
26	23.75	19.25	-9	23.75	19.5	-8.5	0	0.25	0.5
27	23.25	25.25	-8.5	23	25.5	-8.25	-0.25	0.25	0.25
28	24.25	33.25	-7.5	24.25	33.5	-7.25	0	0.25	0.25
29							0	0	0
30							0	0	0

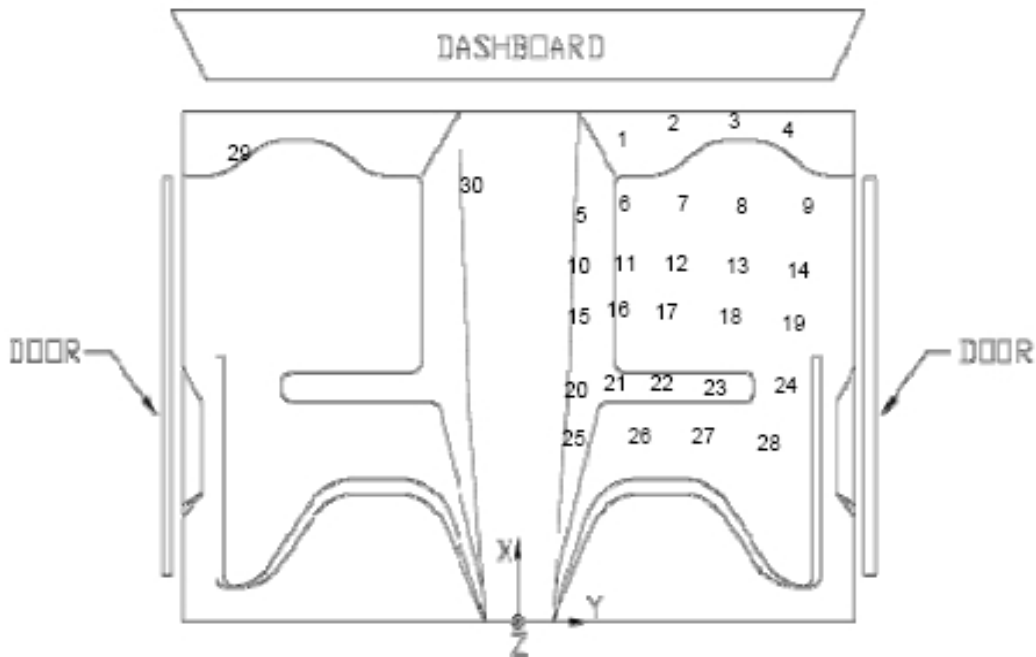

Figure C-2. Occupant Compartment Deformation Data - Set 2, Test No. MGSAS-1

Occupant Compartment Deformation Index (OCDI)

Test No. MGSAS-1
 Vehicle Type: 1999 Chevy C2500

OCDI = XXABCDEFGHI

XX = location of occupant compartment deformation

A = distance between the dashboard and a reference point at the rear of the occupant compartment, such as the top of the rear seat or the rear of the cab on a pickup

B = distance between the roof and the floor panel

C = distance between a reference point at the rear of the occupant compartment and the motor panel

D = distance between the lower dashboard and the floor panel

E = interior width

F = distance between the lower edge of right window and the upper edge of left window

G = distance between the lower edge of left window and the upper edge of right window

H = distance between bottom front corner and top rear corner of the passenger side window

I = distance between bottom front corner and top rear corner of the driver side window

Severity Indices

- 0 - if the reduction is less than 3%
- 1 - if the reduction is greater than 3% and less than or equal to 10 %
- 2 - if the reduction is greater than 10% and less than or equal to 20 %
- 3 - if the reduction is greater than 20% and less than or equal to 30 %
- 4 - if the reduction is greater than 30% and less than or equal to 40 %

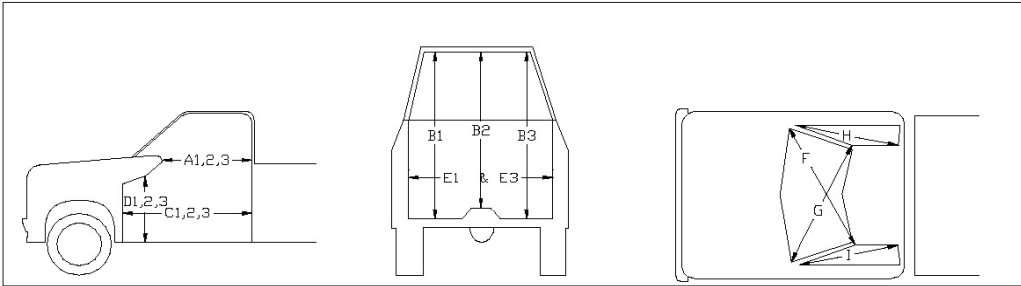

where,
 1 = Passenger Side
 2 = Middle
 3 = Driver Side

Location:

Measurement	Pre-Test (in.)	Post-Test (in.)	Change (in.)	% Difference	Severity Index
A1	39.00	39.00	0.00	0.00	0
A2	39.50	39.50	0.00	0.00	0
A3	39.25	39.25	0.00	0.00	0
B1	46.75	46.75	0.00	0.00	0
B2	41.75	41.75	0.00	0.00	0
B3	46.75	47.00	0.25	0.53	0
C1	58.25	58.75	0.50	0.86	0
C2	54.75	55.00	0.25	0.46	0
C3	58.00	58.00	0.00	0.00	0
D1	16.50	16.00	-0.50	-3.03	1
D2	8.50	8.50	0.00	0.00	0
D3	15.00	15.25	0.25	1.67	0
E1	62.50	62.25	-0.25	-0.40	0
E3	64.25	64.25	0.00	0.00	0
F	57.75	57.75	0.00	0.00	0
G	57.25	57.25	0.00	0.00	0
H	40.25	40.25	0.00	0.00	0
I	40.00	40.00	0.00	0.00	0

Note: Maximum severity index for each variable (A-I) is used for determination of final OCDI value

Final OCDI: XX A B C D E F G H I
 RF 0 0 0 1 0 0 0 0 0

Figure C-3. Occupant Compartment Deformation Index (OCDI), Test No. MGSAS-1

APPENDIX D

Accelerometer and Rate Transducer Data Analysis, Test No. MGSAS-1

Figure D-1. Graph of Longitudinal Deceleration, Test No. MGSAS-1

Figure D-2. Graph of Longitudinal Occupant Impact Velocity, Test No. MGSAS-1

Figure D-3. Graph of Longitudinal Occupant Displacement, Test No. MGSAS-1

Figure D-4. Graph of Lateral Deceleration, Test No. MGSAS-1

Figure D-5. Graph of Lateral Occupant Impact Velocity, Test No. MGSAS-1

Figure D-6. Graph of Lateral Occupant Displacement, Test No. MGSAS-1

Figure D-7. Graph of Roll, Pitch, and Yaw Angular Displacements, Test No. MGSAS-1

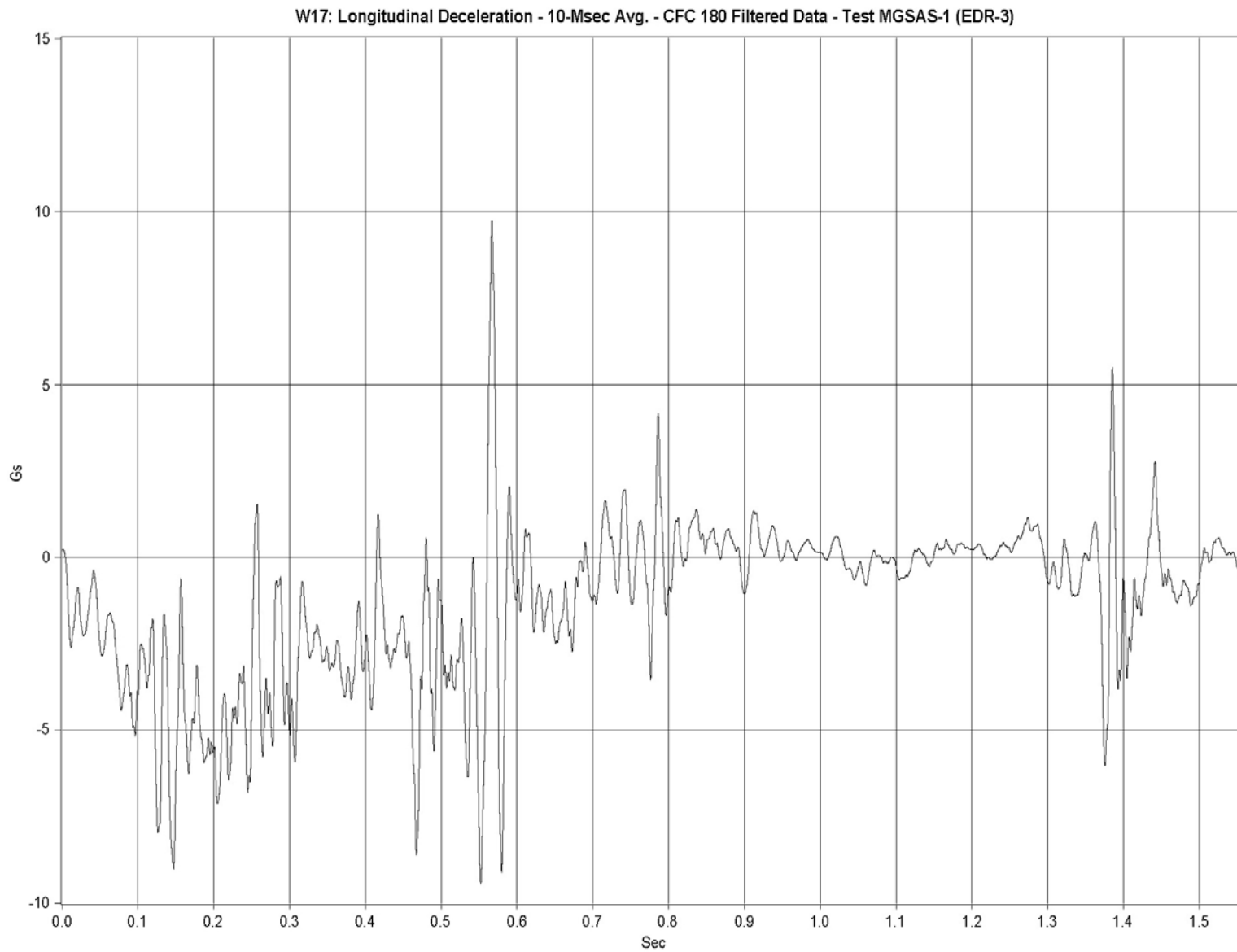

Figure D-1. Graph of Longitudinal Deceleration, Test No. MGSAS-1

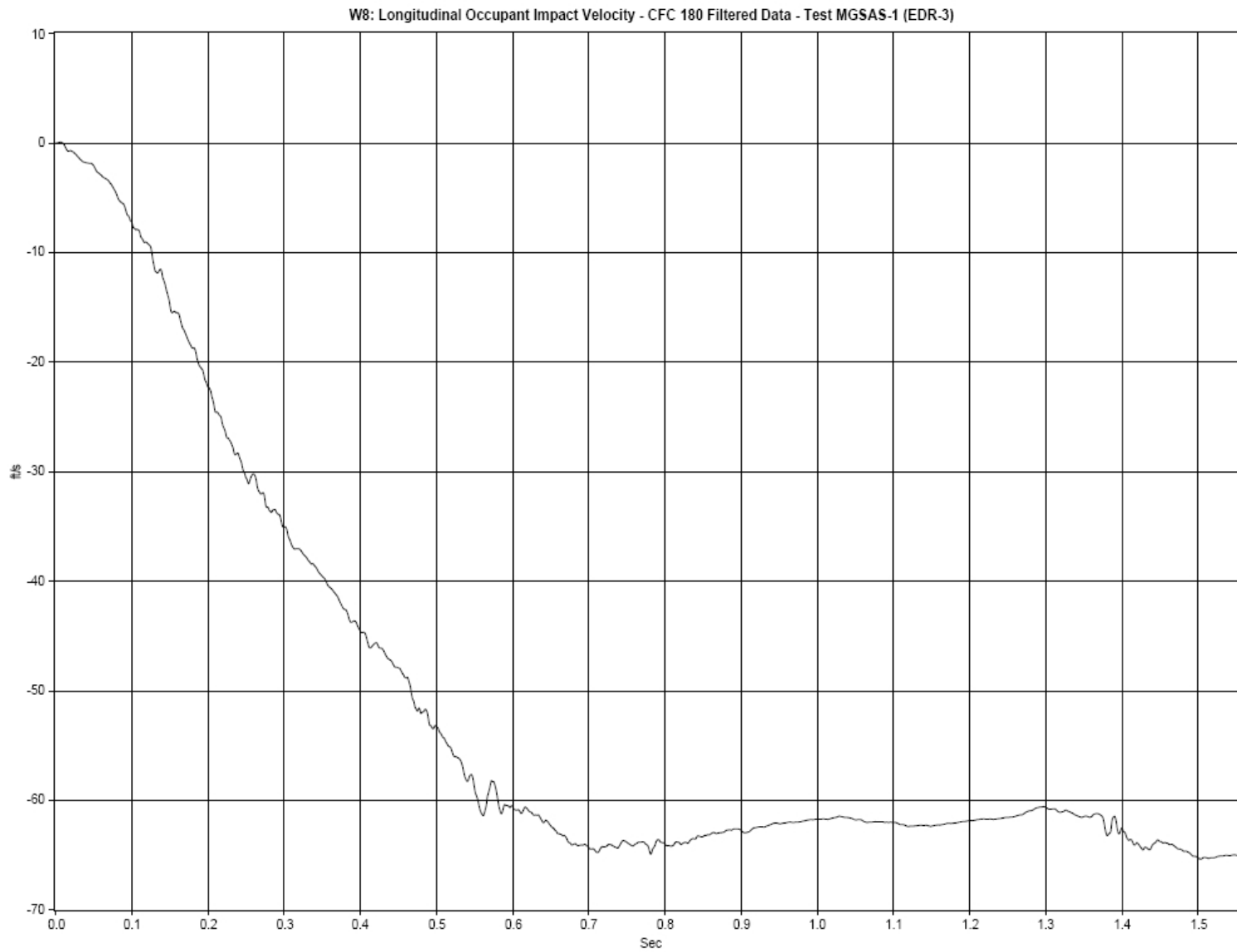

Figure D-2. Graph of Longitudinal Occupant Impact Velocity, Test No. MGSAS-1

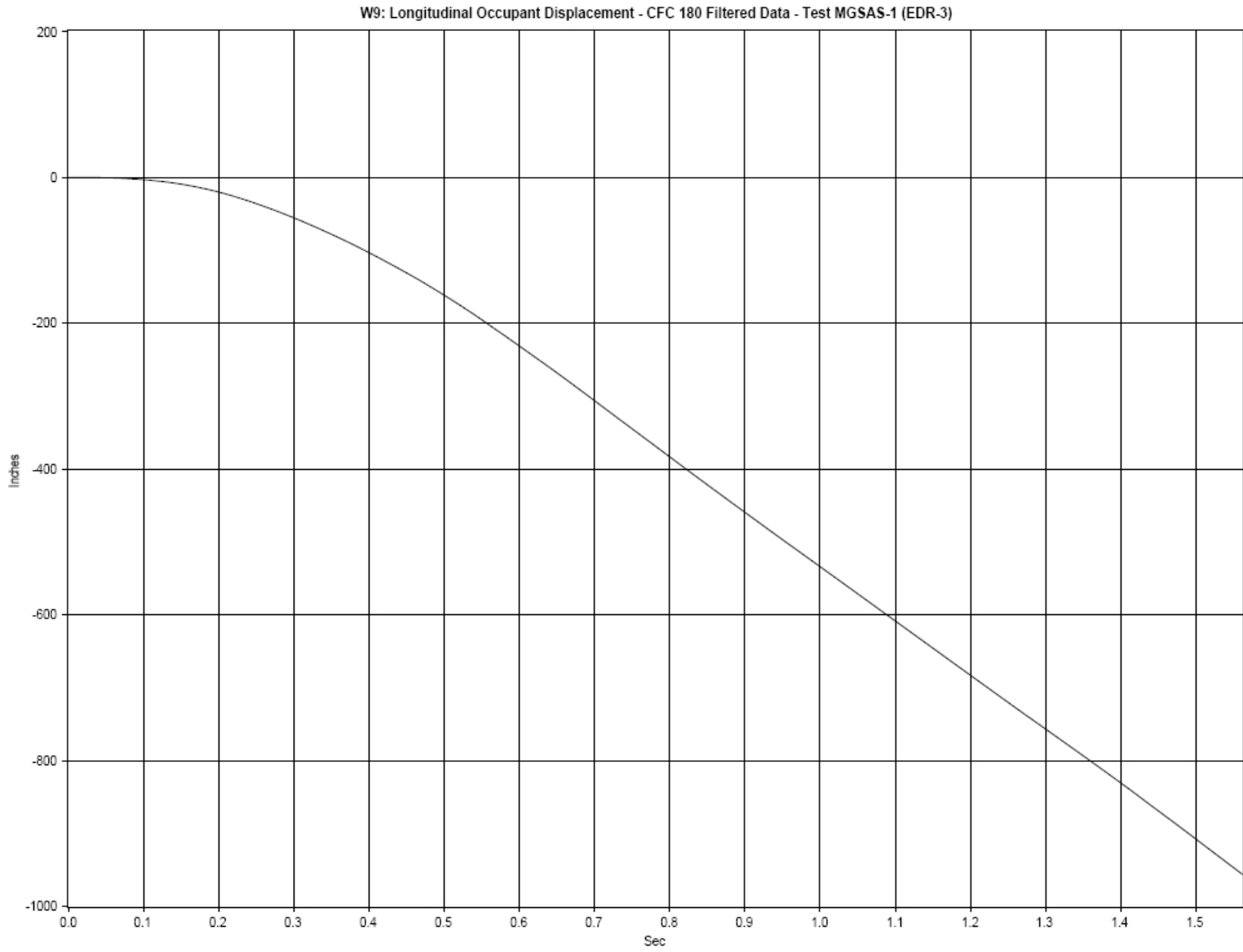

Figure D-3. Graph of Longitudinal Occupant Displacement, Test No. MGSAS-1

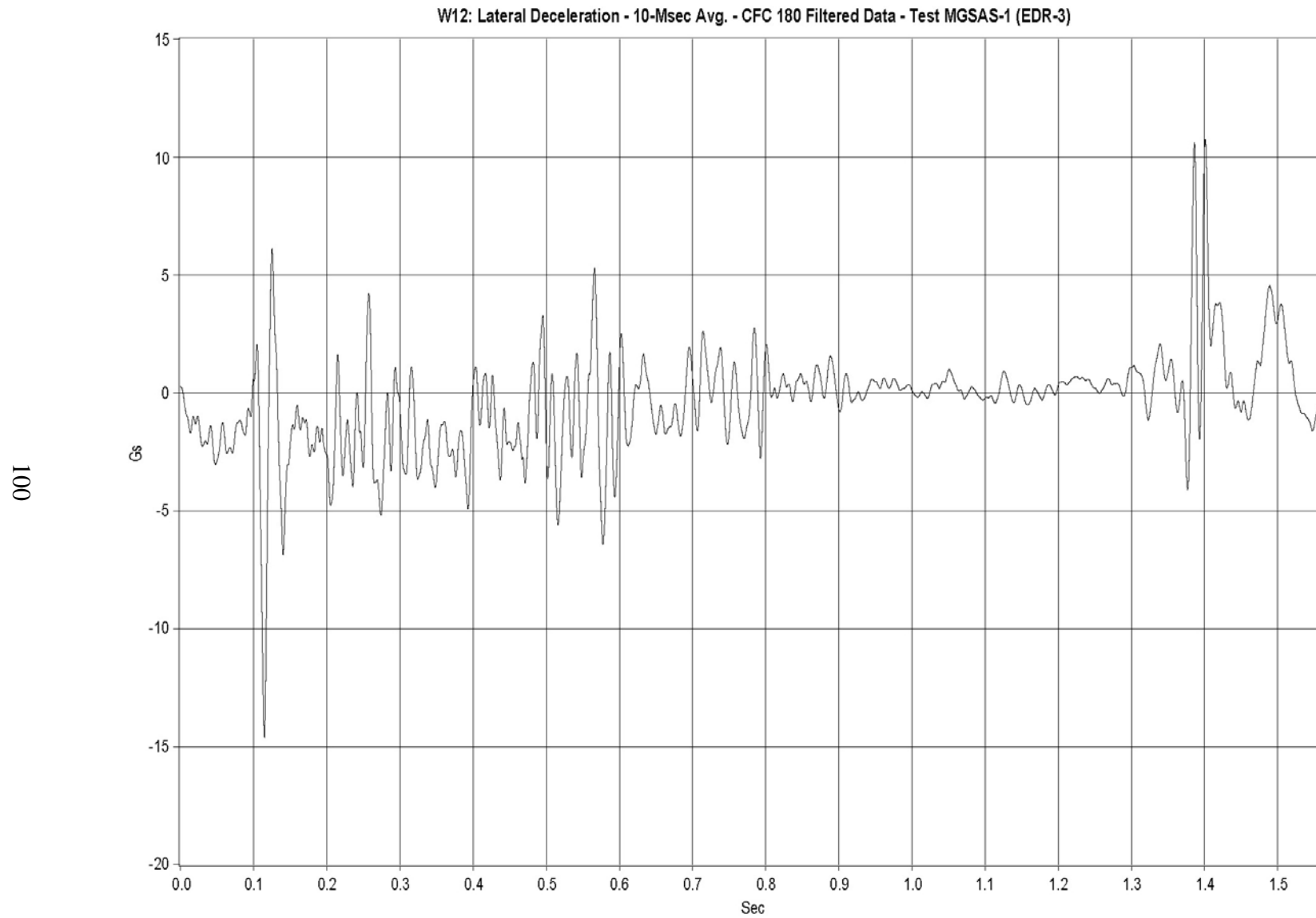

Figure D-4. Graph of Lateral Deceleration, Test No. MGSAS-1

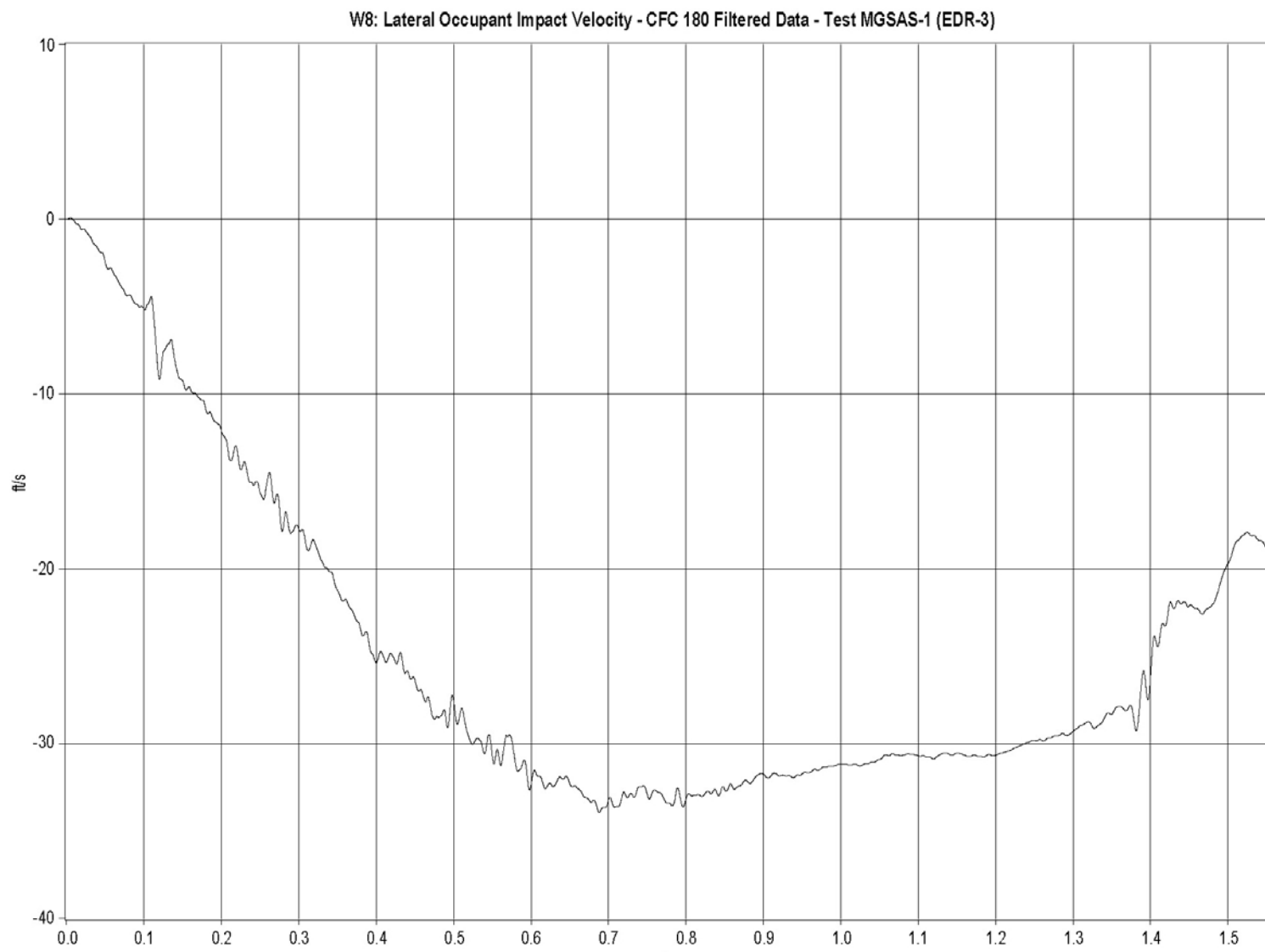

Figure D-5. Graph of Lateral Occupant Impact Velocity, Test No. MGSAS-1

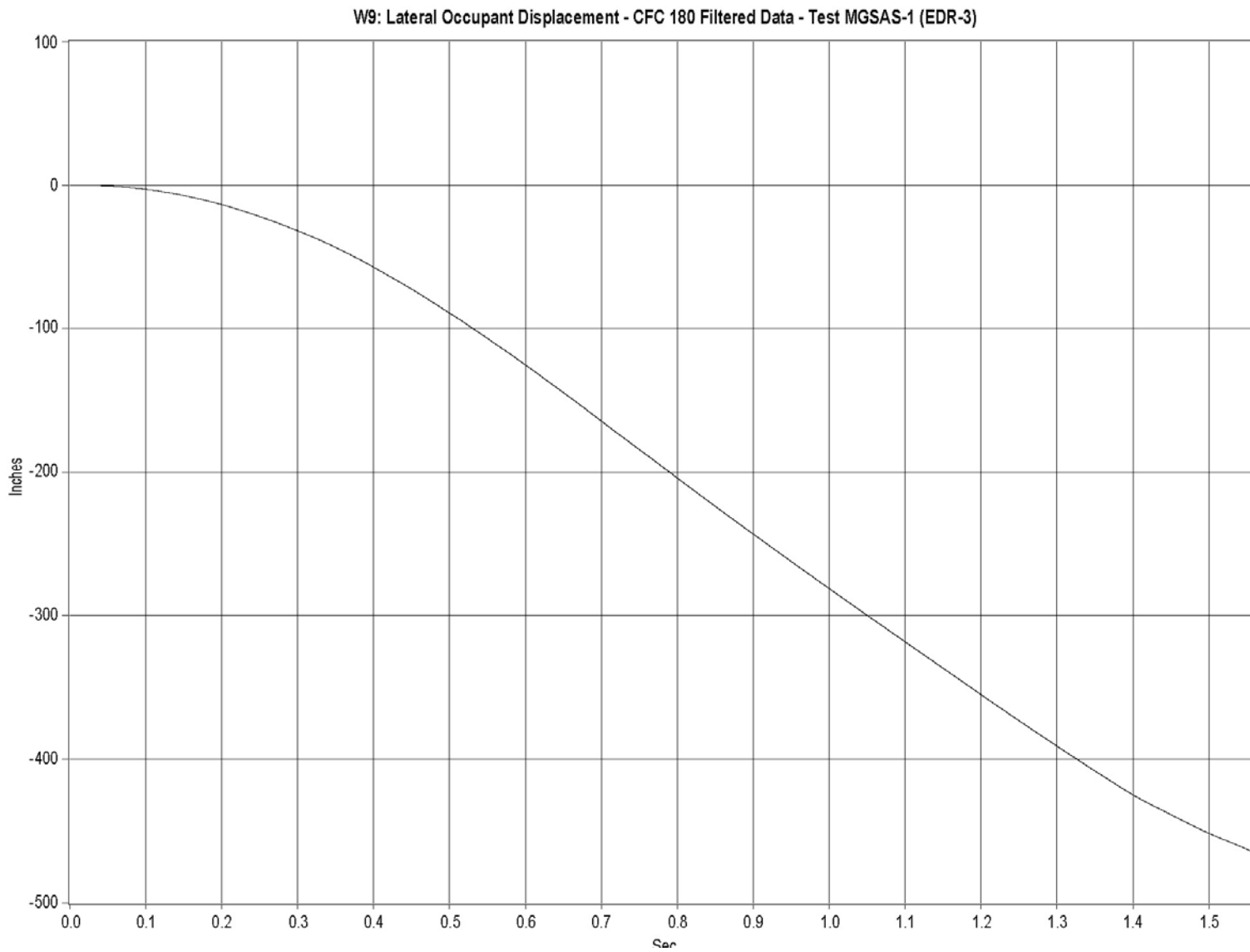

Figure D-6. Graph of Lateral Occupant Displacement, Test No. MGSAS-1

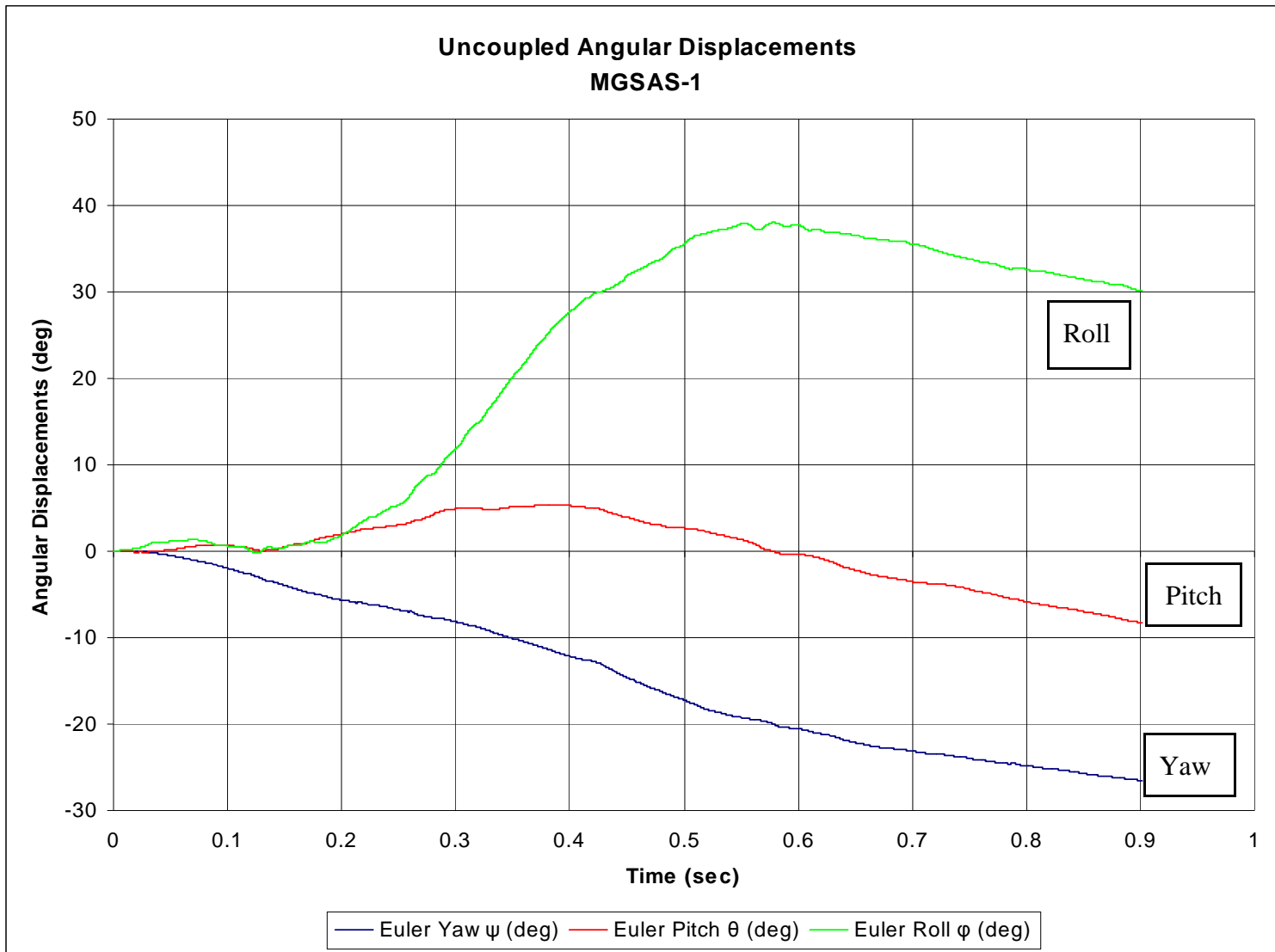

Figure D-7. Graph of Roll, Pitch, and Yaw Angular Displacements, Test No. MGSAS-1

APPENDIX E

Occupant Compartment Deformation Data, Test No. MGSAS-2

Figure E-1. Occupant Compartment Deformation Index (OCDI), Test No. MGSAS-2

Occupant Compartment Deformation Index (OCDI)

Test No. MGSAS-2
 Vehicle Type: 2000 geo metro 2dr

OCDI = XXABCDEFGHI

XX = location of occupant compartment deformation

A = distance between the dashboard and a reference point at the rear of the occupant compartment, such as the top of the rear seat or the rear of the cab on a pickup

B = distance between the roof and the floor panel

C = distance between a reference point at the rear of the occupant compartment and the motor panel

D = distance between the lower dashboard and the floor panel

E = interior width

F = distance between the lower edge of right window and the upper edge of left window

G = distance between the lower edge of left window and the upper edge of right window

H = distance between bottom front corner and top rear corner of the passenger side window

I = distance between bottom front corner and top rear corner of the driver side window

Severity Indices

- 0 - if the reduction is less than 3%
- 1 - if the reduction is greater than 3% and less than or equal to 10 %
- 2 - if the reduction is greater than 10% and less than or equal to 20 %
- 3 - if the reduction is greater than 20% and less than or equal to 30 %
- 4 - if the reduction is greater than 30% and less than or equal to 40 %

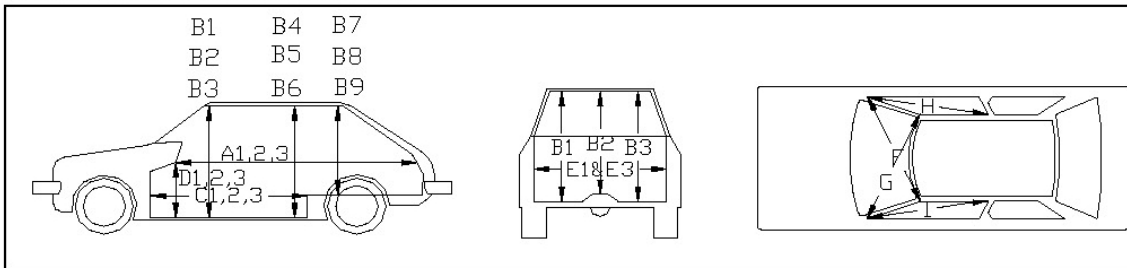

where,
 1 = Passenger Side
 2 = Middle
 3 = Driver Side

Location:

Measurement	Pre-Test (in.)	Post-Test (in.)	Change (in.)	% Difference	Severity Index
A1	46.25	46.25	0.00	0.00	0
A2	44.50	44.25	-0.25	-0.56	0
A3	45.00	45.00	0.00	0.00	0
B1	37.00	37.00	0.00	0.00	0
B2	37.50	37.75	0.25	0.67	0
B3	40.75	41.00	0.25	0.61	0
C1	57.25	57.00	-0.25	-0.44	0
C2	60.50	60.25	-0.25	-0.41	0
C3	57.00	56.75	-0.25	-0.44	0
D1	20.50	20.25	-0.25	-1.22	0
D2	23.50	23.50	0.00	0.00	0
D3	18.25	18.00	-0.25	-1.37	0
E1	49.50	48.75	-0.75	-1.52	0
E3	49.50	49.50	0.00	0.00	0
F	44.75	45.00	0.25	0.56	0
G	44.25	44.00	-0.25	-0.56	0
H	39.50	39.75	0.25	0.63	0
I	39.25	39.50	0.25	0.64	0

Note: Maximum severity index for each variable (A-I) is used for determination of final OCDI value

Final OCDI: XXABCDEFGHI
 RF 0 0 0 0 0 0 0 0 0

Figure E-1. Occupant Compartment Deformation Index (OCDI), Test No. MGSAS-2

APPENDIX F

Accelerometer and Rate Gyro Analysis, Test No. MGSAS-2

Figure F-1. Graph of Longitudinal Deceleration, Test No. MGSAS-2

Figure F-2. Graph of Longitudinal Occupant Impact Velocity, Test No. MGSAS-2

Figure F-3. Graph of Longitudinal Occupant Displacement, Test No. MGSAS-2

Figure F-4. Graph of Lateral Deceleration, Test No. MGSAS-2

Figure F-5. Graph of Lateral Occupant Impact Velocity, Test No. MGSAS-2

Figure F-6. Graph of Lateral Occupant Displacement, Test No. MGSAS-2

Figure F-7. Graph of Roll, Pitch, and Yaw Angular Displacements, Test No. MGSAS-2

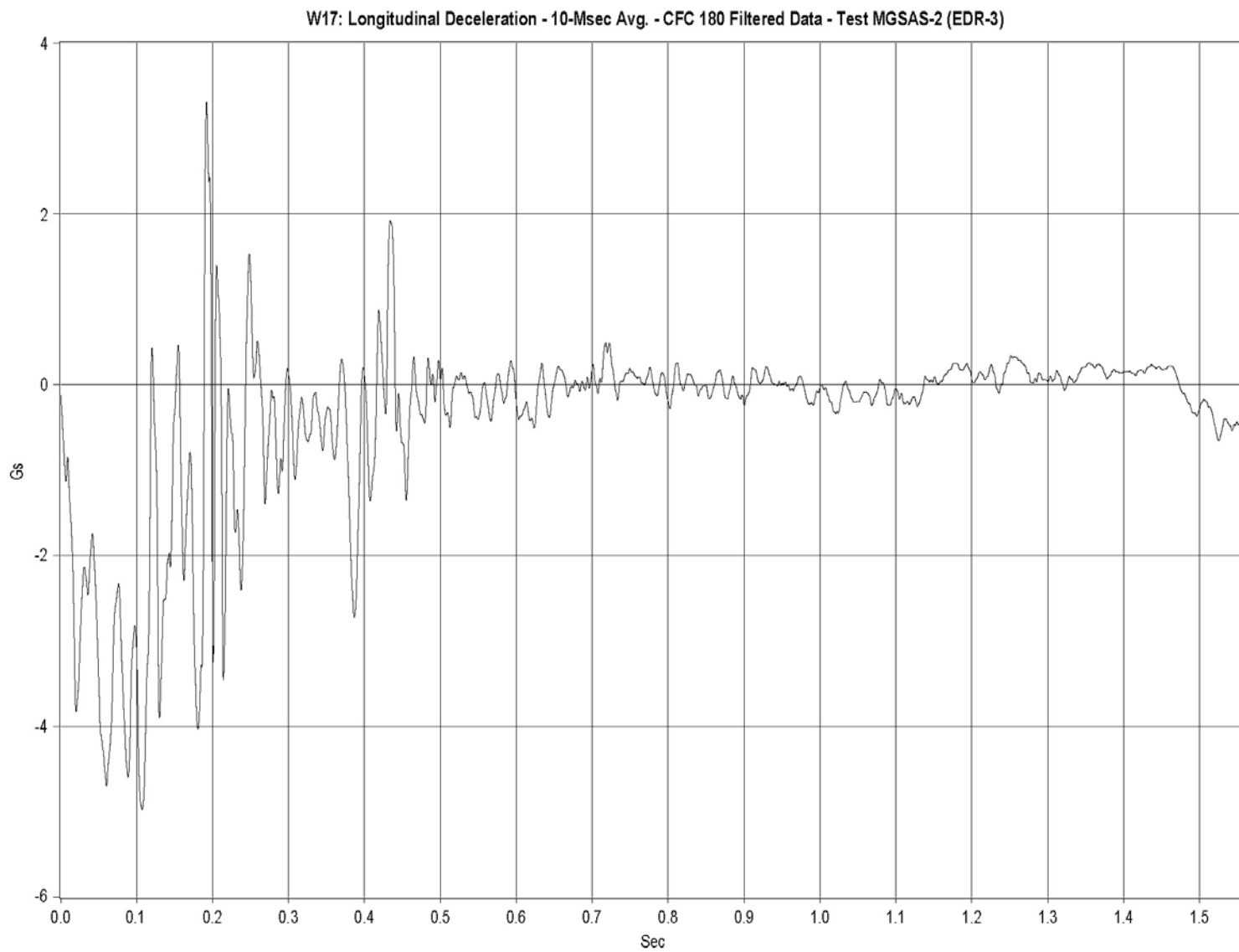

Figure F-1. Graph of Longitudinal Deceleration, Test No. MGSAS-2

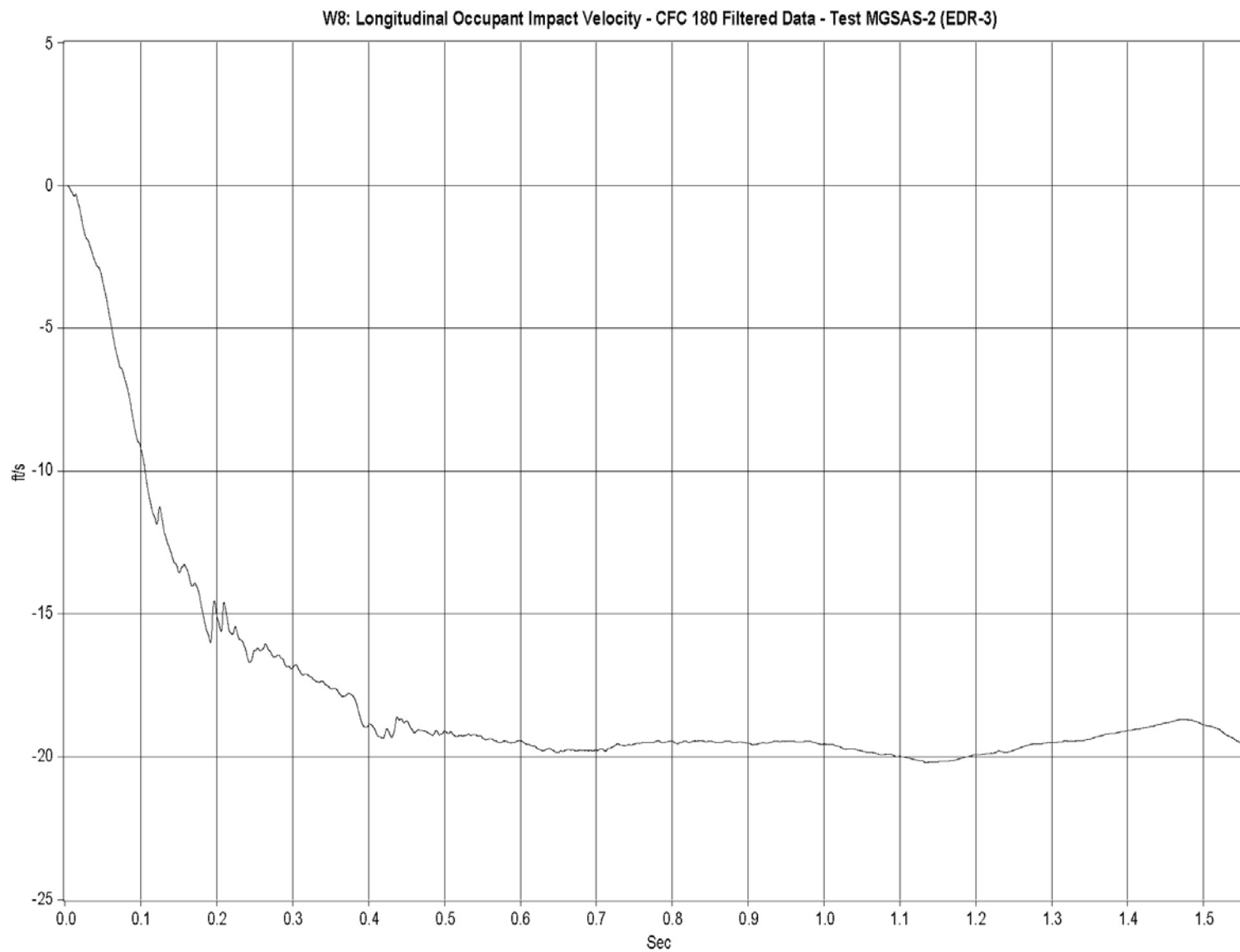

Figure F-2. Graph of Longitudinal Occupant Impact Velocity, Test No. MGSAS-2

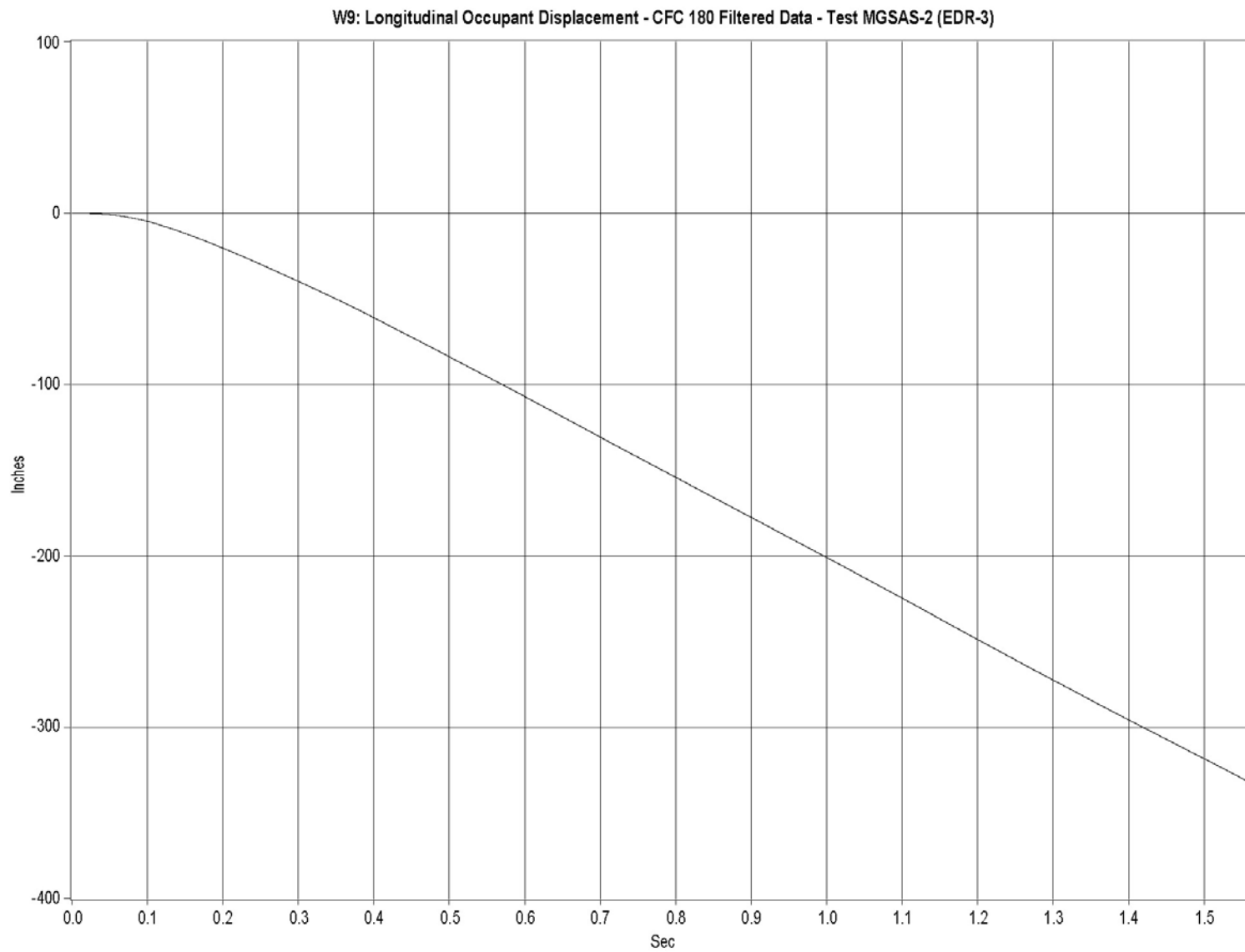

Figure F-3. Graph of Longitudinal Occupant Displacement, Test No. MGSAS-2

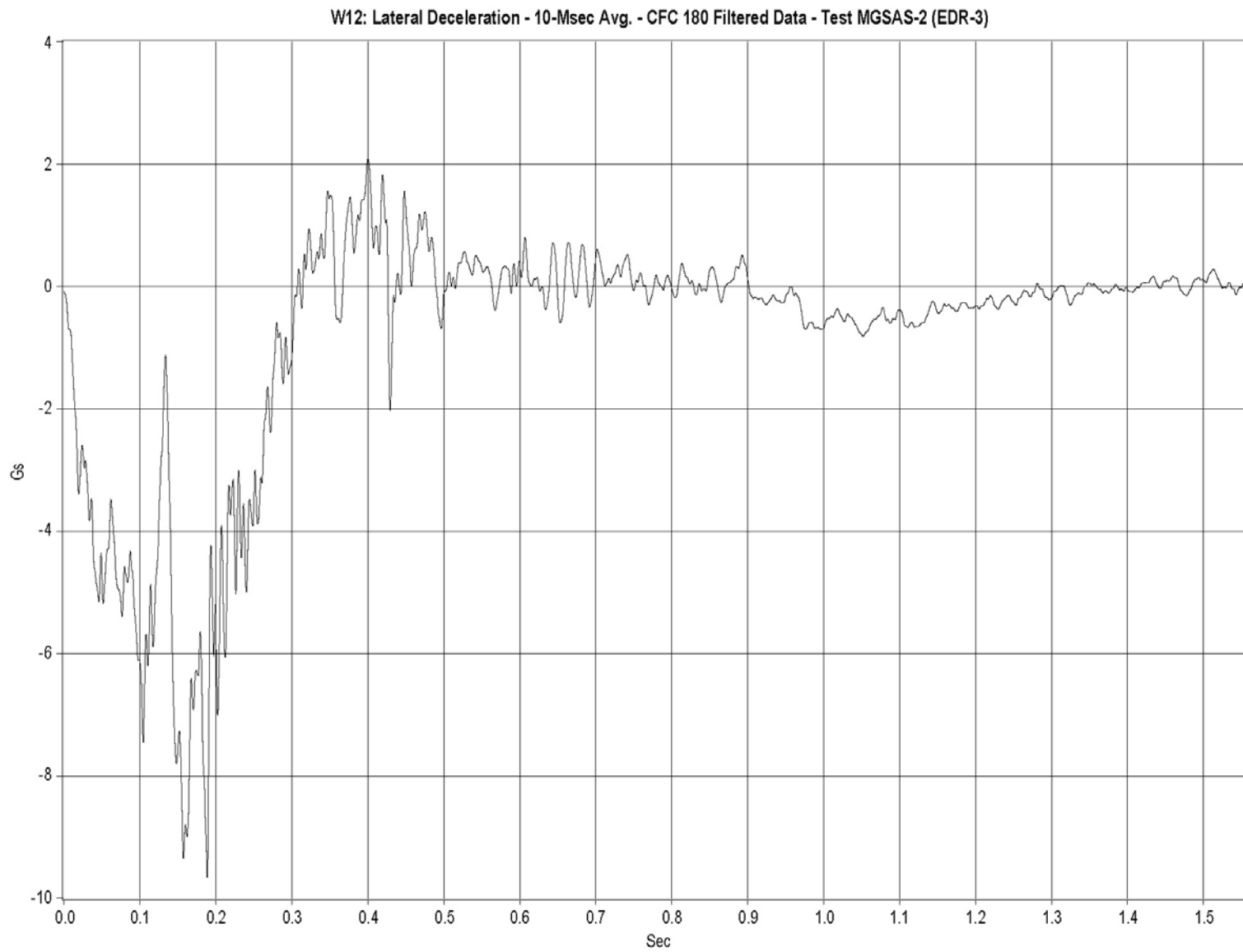

Figure F-4. Graph of Lateral Deceleration, Test No. MGSAS-2

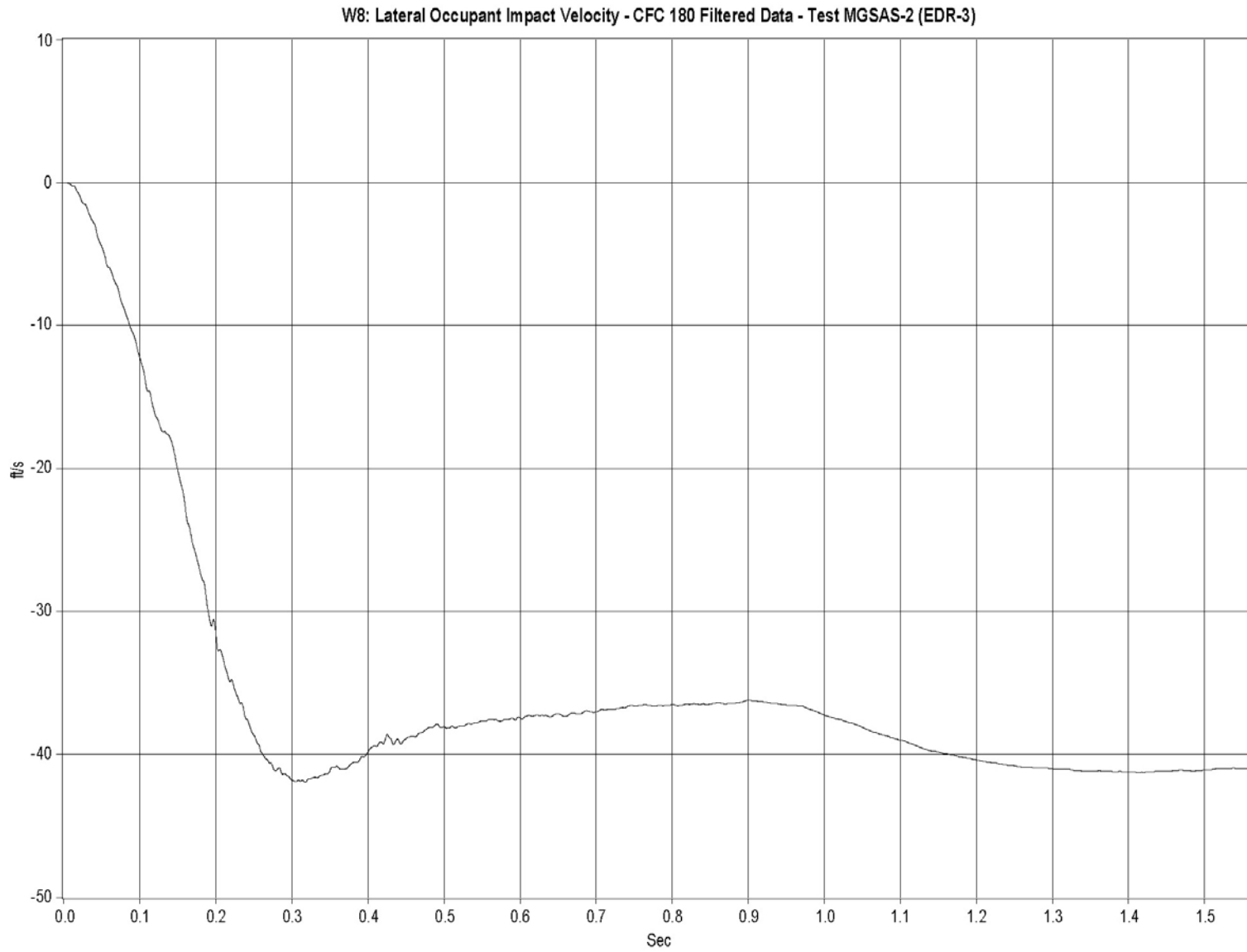

Figure F-5. Graph of Lateral Occupant Impact Velocity, Test No. MGSAS-2

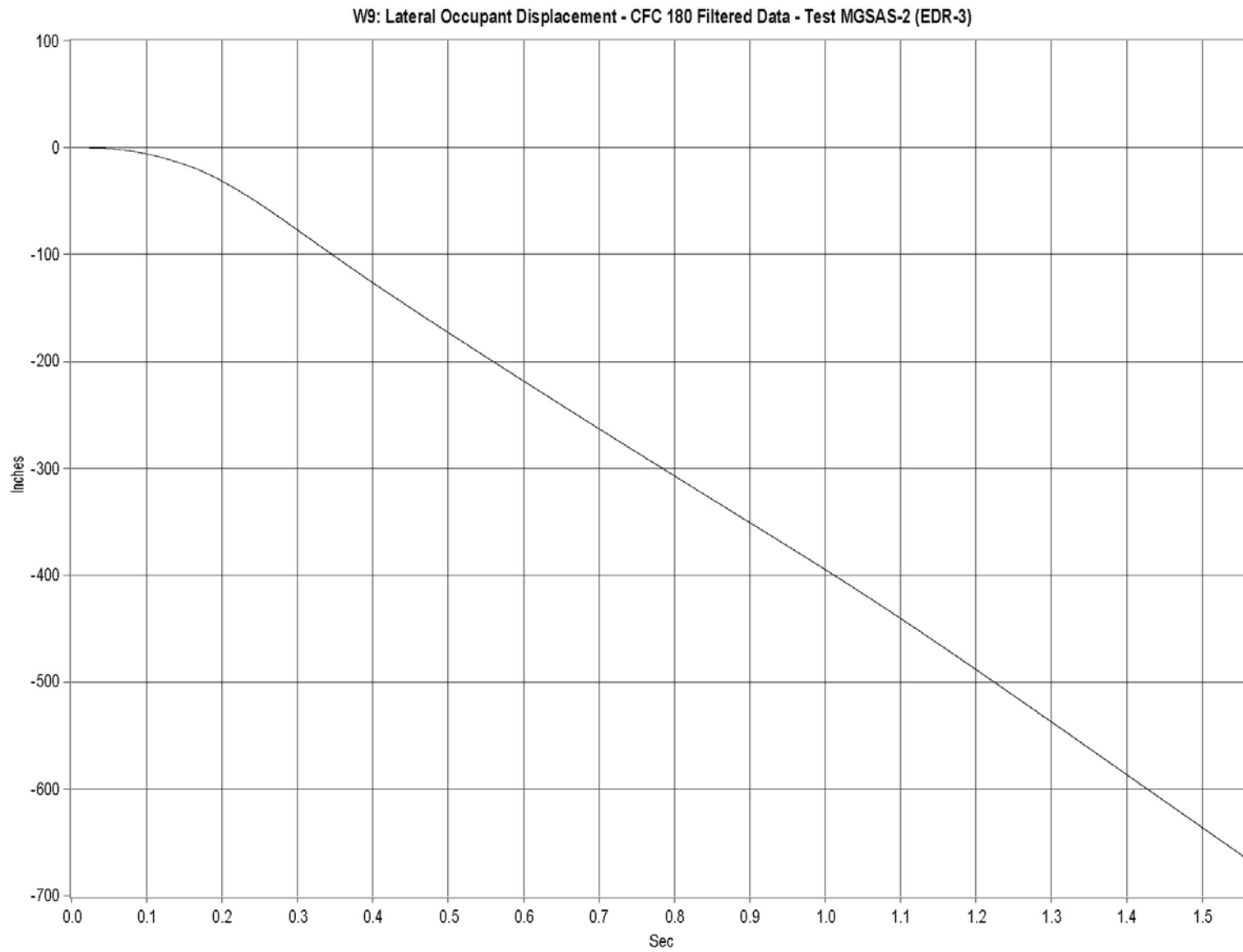

Figure F-6. Graph of Lateral Occupant Displacement, Test No. MGSAS-2

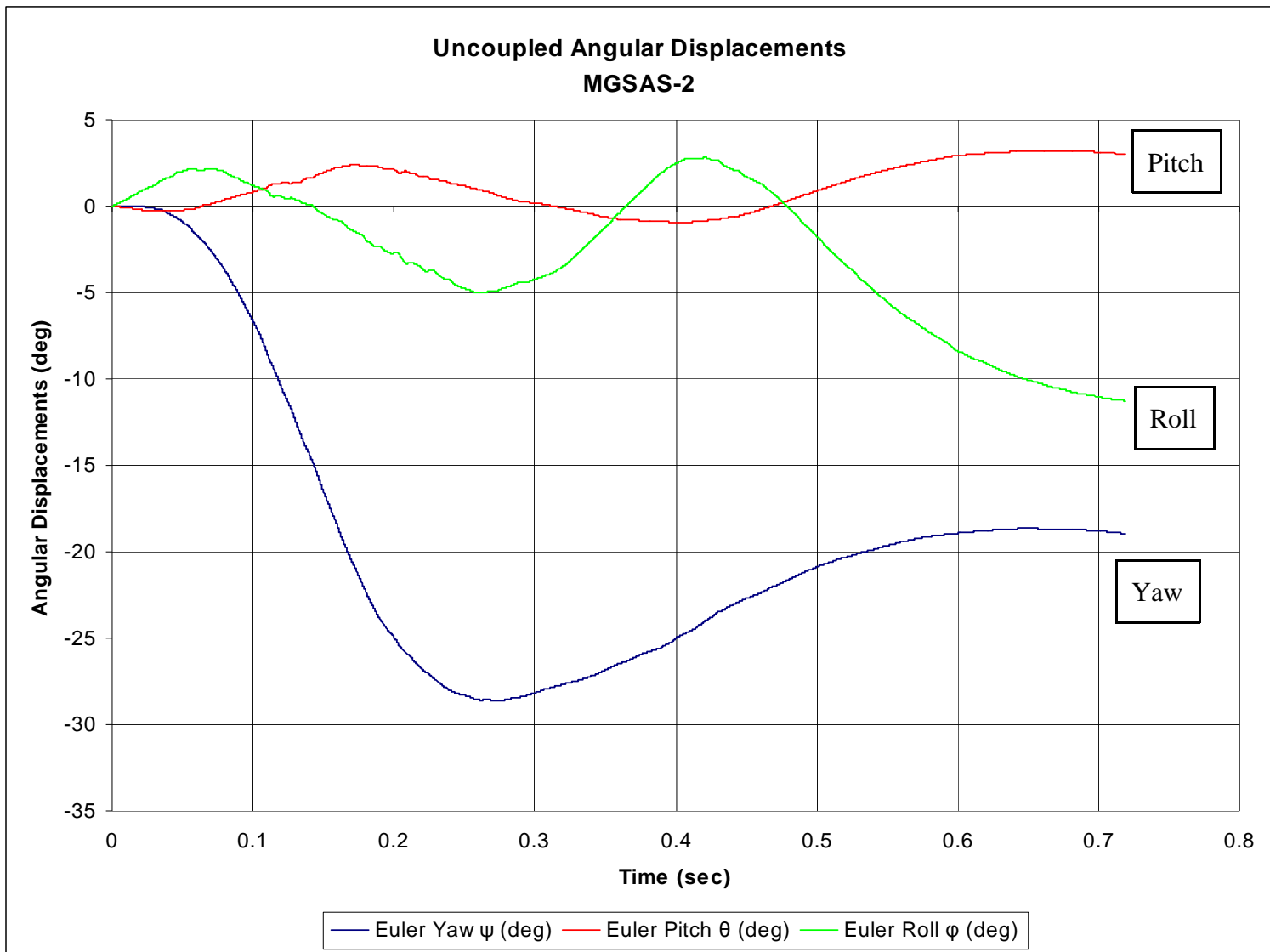

Figure F-7. Graph of Roll, Pitch, and Yaw Angular Displacements, Test No. MGSAS-2