

*Hawaii Department of Transportation
Research Project Number 61767*

CRASH TESTING AND EVALUATION OF THE HDOT 34-IN. TALL AESTHETIC CONCRETE BRIDGE RAIL: MASH TEST DESIGNATION NOS. 3-10 AND 3-11



Submitted by

Robert W. Bielenberg, M.S.M.E, E.I.T
Research Engineer

Seok Hwan Yoo, B.S.
Graduate Research Assistant

Ronald K. Faller, Ph.D., P.E.
Research Professor & MwRSF Director

Erin L. Urbank, B.A.
Research Communication Specialist

MIDWEST ROADSIDE SAFETY FACILITY

Nebraska Transportation Center
University of Nebraska-Lincoln

Main Office

Prem S. Paul Research Center at Whittier School
Room 130, 2200 Vine Street
Lincoln, Nebraska 68583-0853
(402) 472-0965

Outdoor Test Site

4630 N.W. 36th Street
Lincoln, Nebraska 68524

Submitted to

Hawaii Department of Transportation
Aliiimoku Building
869 Punchbowl St.
Honolulu, Hawaii 96813

MwRSF Research Report No. TRP-03-420-19

October 21, 2019

TECHNICAL REPORT DOCUMENTATION PAGE

1. Report No. TRP-03-420-19	2.	3. Recipient's Accession No.	
4. Title and Subtitle Crash Testing and Evaluation of the HDOT 34-in. Tall Aesthetic Concrete Bridge Rail: MASH Test Designation Nos. 3-10 and 3-11		5. Report Date October 21, 2019	
		6.	
7. Author(s) Bielenberg, R.W., Yoo, S., Faller, R.K., and Urbank, E.L.		8. Performing Organization Report No. TRP-03-420-19	
9. Performing Organization Name and Address Midwest Roadside Safety Facility (MwRSF) Nebraska Transportation Center University of Nebraska-Lincoln Main Office: Prem S. Paul Research Center at Whittier School Room 130, 2200 Vine Street Lincoln, Nebraska 68583-0853		10. Project/Task/Work Unit No.	
		11. Contract © or Grant (G) No. Research Project Number 67167	
12. Sponsoring Organization Name and Address Hawaii Department of Transportation Aliiaimoku Building 869 Punchbowl St. Honolulu, Hawaii 96813		13. Type of Report and Period Covered Final Report: 2018-2019	
		14. Sponsoring Agency Code	
15. Supplementary Notes Prepared in cooperation with U.S. Department of Transportation, Federal Highway Administration.			
16. Abstract <p>This report documents two full-scale crash tests conducted in support of a study to investigate the safety performance of the Hawaii Department of Transportation's 34-in. Tall Aesthetic Concrete Bridge Rail system. The barrier system consisted of two 11-ft long concrete rails and three 22-ft long concrete rails anchored to the concrete tarmac. The expansion joint consisted of 24-in. long, No. 8 ASTM A615 Grade 60 steel bars that were casted into the concrete and inserted into a PVC pipe on the upstream side of the expansion joint. Test nos. H34BR-1 and H34BR-2 were conducted according to <i>Manual for Assessing Safety Hardware 2016</i> (MASH 2016) criteria using Test Level 3 (TL-3) test designation nos. 3-10 and 3-11, respectively.</p> <p>In test no. H34BR-1, an 1100C vehicle impacted the bridge rail at a speed of 62.4 mph and at an angle of 25.7 degrees. In test no. H34BR-2, a 2270P vehicle impacted the bridge rail at a speed of 64.0 mph and at an angle of 25.4 degrees. Test nos. H34BR-1 and H34BR-2 resulted in the vehicles being safely redirected without violating any evaluation criteria. Therefore, test nos. H34BR-1 and H34BR-2 successfully met the TL-3 safety performance criteria defined in MASH 2016.</p>			
17. Document Analysis/Descriptors Highway Safety, Crash Test, Roadside Appurtenances, Compliance Test, MASH 2016, Aesthetic, Bridge Rail, Concrete Parapet		18. Availability Statement No restrictions. Document available from: National Technical Information Services, Springfield, Virginia 22161	
19. Security Class (this report) Unclassified	20. Security Class (this page) Unclassified	21. No. of Pages 149	22. Price

DISCLAIMER STATEMENT

This report was completed with funding from the Federal Highway Administration, U.S. Department of Transportation and the Hawaii Department of Transportation. The contents of this report reflect the views and opinions of the authors who are responsible for the facts and the accuracy of the data presented herein. The contents do not necessarily reflect the official views or policies of the Hawaii Department of Transportation nor the Federal Highway Administration, U.S. Department of Transportation. This report does not constitute a standard, specification, regulation, product endorsement, or an endorsement of manufacturers.

UNCERTAINTY OF MEASUREMENT STATEMENT

The Midwest Roadside Safety Facility (MwRSF) has determined the uncertainty of measurements for several parameters involved in standard full-scale crash testing and non-standard testing of roadside safety features. Information regarding the uncertainty of measurements for critical parameters is available upon request by the sponsor and the Federal Highway Administration.

INDEPENDENT APPROVING AUTHORITY

The Independent Approving Authority (IAA) for the data contained herein was Dr. Jennifer Rasmussen, Research Assistant Professor.

ACKNOWLEDGEMENTS

The authors wish to acknowledge several sources that made a contribution to this project: (1) the Hawaii Department of Transportation and (2) MwRSF personnel for constructing the barriers and conducting the crash tests.

Acknowledgement is also given to the following individuals who made a contribution to the completion of this research project.

Midwest Roadside Safety Facility

J.D. Reid, Ph.D., Professor
C.R. Song, Ph.D., A.E., M.ASCE, Associate Professor
J.S. Steelman, Ph.D., P.E., Assistant Professor
M. Asadollahi Pajouh, Ph.D., Assistant Professor, University of Nevada, Las Vegas
S.A. Ranjha, Ph.D., Former Post-Doctoral Research Associate
J.C. Holloway, M.S.C.E., E.I.T., Research Engineer & Assistant Director –Physical Testing Division
K.A. Lechtenberg, M.S.M.E., E.I.T., Research Engineer
S.K. Rosenbaugh, M.S.C.E., E.I.T., Research Engineer
J.D. Schmidt, Ph.D., P.E., Research Assistant Professor
C.S. Stolle, Ph.D., Research Assistant Professor
A.T. Russell, B.S.B.A., Testing and Maintenance Technician II
E.W. Krier, B.S., Construction and Testing Technician II
S.M. Tighe, Construction and Testing Technician I
D.S. Charroin, Construction and Testing Technician I
R.M. Novak, Construction and Testing Technician I
T.C. Donahoo, Construction and Testing Technician I
J.T. Jones, Construction and Testing Technician I
C.I. Sims, Construction and Testing Technician I
J.E. Kohtz, B.S.M.E., CAD Technician
Z.Z. Jabr, Engineering Technician
Undergraduate and Graduate Research Assistants

Hawaii Department of Transportation

Dean Takiguchi, P.E., Bridge Design Engineer
Kimberly Okamura, Bridge Design Engineer
James Fu, P.E., State Bridge Engineer

TABLE OF CONTENTS

TECHNICAL REPORT DOCUMENTATION PAGE i

DISCLAIMER STATEMENT ii

UNCERTAINTY OF MEASUREMENT STATEMENT ii

INDEPENDENT APPROVING AUTHORITY..... ii

ACKNOWLEDGEMENTS iii

TABLE OF CONTENTS..... iv

LIST OF FIGURES vi

LIST OF TABLES ix

1 INTRODUCTION 1

 1.1 Background 1

 1.2 Objective 7

 1.3 Scope..... 7

2 TEST REQUIREMENTS AND EVALUATION CRITERIA 8

 2.1 Test Requirements 8

 2.2 Evaluation Criteria 9

3 DESIGN DETAILS 10

4 TEST CONDITIONS..... 23

 4.1 Test Facility 23

 4.2 Vehicle Tow and Guidance System 23

 4.3 Test Vehicles 23

 4.4 Simulated Occupant 33

 4.5 Data Acquisition Systems 33

 4.5.1 Accelerometers 33

 4.5.2 Retroreflective Optic Speed Trap 34

 4.5.3 Rate Transducers..... 34

 4.5.4 Digital Photography 34

5 FULL-SCALE CRASH TEST NO. H34BR-1 37

 5.1 Weather Conditions 37

 5.2 Test Description 37

 5.3 Barrier Damage 47

 5.4 Vehicle Damage..... 53

 5.5 Occupant Risk..... 60

 5.6 Barrier Loads 61

 5.7 Discussion 62

6 FULL-SCALE CRASH TEST NO. H34BR-2 64

- 6.1 Weather Conditions 64
- 6.2 Test Description 64
- 6.3 Barrier Damage 73
- 6.4 Vehicle Damage 78
- 6.5 Occupant Risk 85
- 6.6 Barrier Loads 86
- 6.7 Discussion 87

7 SUMMARY, CONCLUSIONS, AND RECOMMENDATIONS 89

8 REFERENCES 92

9 APPENDICES 93

- Appendix A. Material Specifications 94
- Appendix B. Vehicle Center of Gravity Determination 104
- Appendix C. Vehicle Deformation Records 107
- Appendix D. Accelerometer and Rate Transducer Data Plots, Test No. H34BR-1 116
- Appendix E. Accelerometer and Rate Transducer Data Plots, Test No. H34BR-2 132

LIST OF FIGURES

Figure 1. HDOT Standard Detail for the 34-in. Tall, Aesthetic Concrete Bridge Rail	2
Figure 2. HDOT Standard Detail for the 34-in. Tall, Aesthetic Concrete Bridge Rail	3
Figure 3. HDOT Standard Detail for the 34-in. Tall, Aesthetic Concrete Bridge Rail	4
Figure 4. HDOT Standard Detail for the 34-in. Tall, Aesthetic Concrete Bridge Rail	5
Figure 5. Final Design Guidelines for Aesthetic Surface Treatments of Safety Shape Concrete Barrier [1]	6
Figure 6. Test Installation Layout, Test Nos. H34BR-1 and H34BR-2.....	11
Figure 7. Section Details, Test Nos. H34BR-1 and H34BR-2.....	12
Figure 8. Reinforcement Detail, Test Nos. H34BR-1 and H34BR-2	13
Figure 9. Expansion Joint Details, Test Nos. H34BR-1 and H34BR-2.....	14
Figure 10. 11-ft Concrete Parapet Details, Test Nos. H34BR-1 and H34BR-2	15
Figure 11. 22-ft Concrete Parapet Details, Test Nos. H34BR-1 and H34BR-2	16
Figure 12. Rebar Details, Test Nos. H34BR-1 and H34BR-2	17
Figure 13. Expansion Joint Components, Test Nos. H34BR-1 and H34BR-2	18
Figure 14. Bill of Materials, Test Nos. H34BR-1 and H34BR-2	19
Figure 15. Test Installation Photographs, Test Nos. H34BR-1 and H34BR-2.....	20
Figure 16. Test Installation Photographs, Back Side, Test Nos. H34BR-1 and H34BR-2.....	21
Figure 17. Test Installation Photographs, Traffic Side, Test Nos. H34BR-1 and H34BR-2.....	22
Figure 18. Test Vehicle, Test No. H34BR-1	24
Figure 19. Test Vehicle’s Interior Floorboards and Undercarriage, Test No. H34BR-1.....	25
Figure 20. Vehicle Dimensions, Test No. H34BR-1	26
Figure 21. Test Vehicle, Test No. H34BR-2	28
Figure 22. Test Vehicle’s Interior Floorboards and Undercarriage, Test No. H34BR-2.....	29
Figure 23. Vehicle Dimensions, Test No. H34BR-2	30
Figure 24. Target Geometry, Test No. H34BR-1	31
Figure 25. Target Geometry, Test No. H34BR-2	32
Figure 26. Camera Locations, Speeds, and Lens Settings, Test No. H34BR-1.....	35
Figure 27. Camera Locations, Speeds, and Lens Settings, Test No. H34BR-2.....	36
Figure 28. Impact Location, Test No. H34BR-1	38
Figure 29. Sequential Photographs, Test No. H34BR-1	41
Figure 30. Additional Sequential Photographs, Test No. H34BR-1	42
Figure 31. Documentary Photographs, Test No. H34BR-1	43
Figure 32. Additional Documentary Photographs, Test No. H34BR-1	44
Figure 33. Additional Documentary Photographs, Test No. H34BR-1	45
Figure 34. Vehicle Final Position and Trajectory Marks, Test No. H34BR-1	46
Figure 35. System Damage, Test No. H34BR-1.....	48
Figure 36. Traffic-Side System Damage, Test No. H34BR-1	49
Figure 37. Traffic-Side System Damage, Test No. H34BR-1	50
Figure 38. Traffic-Side System Damage, Test No. H34BR-1	51
Figure 39. Back-Side System Damage, Test No. H34BR-1	52
Figure 40. Permanent Set Deflection, Dynamic Deflection, and Working Width, Test No. H34BR-1	53
Figure 41. Vehicle Damage, Test No. H34BR-1	55
Figure 42. Vehicle Damage, Test No. H34BR-1	56
Figure 43. Vehicle Damage, Test No. H34BR-1	57

Figure 44. Interior Floorboard Damage, Test No. H34BR-158
Figure 45. Undercarriage Damage, Test No. H34BR-1.....59
Figure 46. Perpendicular and Tangential Forces Imparted to the Barrier System (SLICE-2),
Test No. H34BR-162
Figure 47. Summary of Test Results and Sequential Photographs, Test No. H34BR-1.....63
Figure 48. Impact Location, Test No. H34BR-265
Figure 49. Sequential Photographs, Test No. H34BR-2.....67
Figure 50. Additional Sequential Photographs, Test No. H34BR-2.....68
Figure 51. Documentary Photographs, Test No. H34BR-2.....69
Figure 52. Additional Documentary Photographs, Test No. H34BR-2.....70
Figure 53. Additional Documentary Photographs, Test No. H34BR-2.....71
Figure 54. Vehicle Final Position & Trajectory Marks, Test No. H34BR-272
Figure 55. System Damage, Test No. H34BR-2.....74
Figure 56. Traffic-Side System Damage, Test No. H34BR-275
Figure 57. Traffic-Side System Damage, Test No. H34BR-276
Figure 58. Back-Side System Damage, Test No. H34BR-277
Figure 59. Permanent Set Deflection, Dynamic Deflection, and Working Width, Test No.
H34BR-278
Figure 60. Vehicle Damage, Test No. H34BR-280
Figure 61. Vehicle Damage, Test No. H34BR-281
Figure 62. Vehicle Damage, Test No. H34BR-282
Figure 63. Interior Floorboard Damage, Test No. H34BR-2.....83
Figure 64. Undercarriage Damage, Test No. H34BR-2.....84
Figure 65. Perpendicular and Tangential Forces Imparted to the Barrier System (SLICE-2),
Test No. H34BR-287
Figure 66. Summary of Test Results and Sequential Photographs, Test No. H34BR-2.....88
Figure A-1. Reinforced Concrete, Test Nos. H34BR-1 and H34BR-296
Figure A-2. Compression Test Cylindrical Concrete Specimen, Test Nos. H34BR-1 and
H34BR-297
Figure A-3. Low-Strength Concrete Overlay, Test Nos. H34BR-1 and H34BR-298
Figure A-4. #5 Rebar, Test Nos. H34BR-1 and H34BR-299
Figure A-5. #8 Rebar, Test Nos. H34BR-1 and H34BR-2100
Figure A-6. 1¼-in. Dia. PVC Pipe and 1¼-in. PVC Cap, Test Nos. H34BR-1 and H34BR-2 ...101
Figure A-7. Epoxy Adhesive, Test Nos. H34BR-1 and H34BR-2102
Figure A-8. Expansion Joint Sealant, Test Nos. H34BR-1 and H34BR-2103
Figure B-1. Vehicle Mass Distribution, Test No. H34BR-1.....105
Figure B-2. Vehicle Mass Distribution, Test No. H34BR-2.....106
Figure C-1. Floor Pan Deformation Data – Set 1, Test No. H34BR-1108
Figure C-2. Floor Pan Deformation Data – Set 2, Test No. H34BR-1109
Figure C-3. Floor Pan Deformation Data – Set 1, Test No. H34BR-2110
Figure C-4. Floor Pan Deformation Data – Set 2, Test No. H34BR-2111
Figure C-5. Exterior Vehicle Crush (NASS) - Front, Test No. H34BR-1112
Figure C-6. Exterior Vehicle Crush (NASS) - Side, Test No. H34BR-1113
Figure C-7. Exterior Vehicle Crush (NASS) - Front, Test No. H34BR-2.....114
Figure D-1. 10-ms Average Longitudinal Deceleration (SLICE-2), Test No. H34BR-1.....117
Figure D-2. Longitudinal Occupant Impact Velocity (SLICE-2), Test No. H34BR-1.....118
Figure D-3. Longitudinal Occupant Displacement (SLICE-2), Test No. H34BR-1119

Figure D-4. 10-ms Average Lateral Deceleration (SLICE-2), Test No. H34BR-1120
Figure D-5. Lateral Occupant Impact Velocity (SLICE-2), Test No. H34BR-1121
Figure D-6. Lateral Occupant Displacement (SLICE-2), Test No. H34BR-1122
Figure D-7. Vehicle Angular Displacements (SLICE-2), Test No. H34BR-1123
Figure D-8. Acceleration Severity Index (SLICE-2), Test No. H34BR-1124
Figure D-9. 10-ms Average Longitudinal Deceleration (DTS), Test No. H34BR-1125
Figure D-10. Longitudinal Occupant Impact Velocity (DTS), Test No. H34BR-1126
Figure D-11. Longitudinal Occupant Displacement (DTS), Test No. H34BR-1127
Figure D-12. 10-ms Average Lateral Deceleration (DTS), Test No. H34BR-1128
Figure D-13. Lateral Occupant Impact Velocity (DTS), Test No. H34BR-1129
Figure D-14. Lateral Occupant Displacement (DTS), Test No. H34BR-1130
Figure D-15. Acceleration Severity Index (DTS), Test No. H34BR-1131
Figure E-1. 10-ms Average Longitudinal Deceleration (SLICE-1), Test No. H34BR-2133
Figure E-2. Longitudinal Occupant Impact Velocity (SLICE-1), Test No. H34BR-2134
Figure E-3. Longitudinal Occupant Displacement (SLICE-1), Test No. H34BR-2135
Figure E-4. 10-ms Average Lateral Deceleration (SLICE-1), Test No. H34BR-2136
Figure E-5. Lateral Occupant Impact Velocity (SLICE-1), Test No. H34BR-2137
Figure E-6. Lateral Occupant Displacement (SLICE-1), Test No. H34BR-2138
Figure E-7. Vehicle Angular Displacements (SLICE-1), Test No. H34BR-2139
Figure E-8. Acceleration Severity Index (SLICE-1), Test No. H34BR-2140
Figure E-9. 10-ms Average Longitudinal Deceleration (SLICE-2), Test No. H34BR-2141
Figure E-10. Longitudinal Occupant Impact Velocity (SLICE-2), Test No. H34BR-2142
Figure E-11. Longitudinal Occupant Displacement (SLICE-2), Test No. H34BR-2143
Figure E-12. 10-ms Average Lateral Deceleration (SLICE-2), Test No. H34BR-2144
Figure E-13. Lateral Occupant Impact Velocity (SLICE-2), Test No. H34BR-2145
Figure E-14. Lateral Occupant Displacement (SLICE-2), Test No. H34BR-2146
Figure E-15. Vehicle Angular Displacements (SLICE-2), Test No. H34BR-2147
Figure E-16. Acceleration Severity Index (SLICE-2), Test No. H34BR-2148

LIST OF TABLES

Table 1. MASH 2016 TL-3 Crash Test Conditions for Longitudinal Barriers.....8
Table 2. MASH 2016 Evaluation Criteria for Longitudinal Barriers9
Table 3. Weather Conditions, Test No. H34BR-137
Table 4. Sequential Description of Impact Events, Test No. H34BR-139
Table 5. Maximum Occupant Compartment Intrusion by Location, Test No. H34BR-160
Table 6. Summary of OIV, ORA, THIV, PHD, and ASI Values, Test No. H34BR-161
Table 7. Weather Conditions, Test No. H34BR-264
Table 8. Sequential Description of Impact Events, Test No. H34BR-266
Table 9. Maximum Occupant Compartment Intrusion by Location, Test No. H34BR-285
Table 10. Summary of OIV, ORA, THIV, PHD, and ASI Values, Test No. H34BR-2.....86
Table 11. Summary of Safety Performance Evaluation.....91
Table A-1. Bill of Materials, Test Nos. H34BR-1 and H34BR-2.....95

1 INTRODUCTION

1.1 Background

The Hawaii Department of Transportation (HDOT) utilizes several concrete bridge rails with aesthetic treatments. However, the crashworthiness of these bridge railings under current impact safety standards has not been demonstrated until recently. This report documents two full-scale crash tests conducted in support of a study to evaluate the safety performance of HDOT's 34-in. tall, Aesthetic Concrete Bridge Rail with aesthetic recessed rectangular panels added to its traffic-side and back surfaces. The original standard plans of the HDOT 34-in. tall, Aesthetic Concrete Bridge Rail are shown in Figures 1 through 4. The recessed rectangular panels for the HDOT 34-in. bridge rail are 60 in. wide, 15 in. tall, and ½ in. deep with an inclination angle of 45 degrees. The concrete bridge rail is anchored to a concrete bridge deck, and a 2-in. thick concrete or asphalt finishing surface is applied on the traffic-side face of the bridge rail. Expansion joints using smooth dowels are located at intervals in the bridge rail. End sections measuring 3 ft – 6 in. long are used at the ends of the bridge rail adjacent to an end buttress structure.

Several years ago, researchers at the Texas A&M Transportation Institute (TTI) published National Cooperative Highway Research Program (NCHRP) Report No. 554 [1], which developed design guidelines for aesthetic treatments for safety shape concrete roadway barriers using a series of Finite Element Modeling (FEM) simulations in conjunction with physical crash testing. The computer simulation effort examined the effect of asperity width and depth as well as the inclination angle of the asperity surface. A parametric FEM analysis was performed for asperity angles of 30, 45, and 90 degrees as measured from the front face of the barrier, and the simulation outcomes were categorized as acceptable, marginal/unknown, and unacceptable. NCHRP Report No. 554 provided final design guidelines for safety shape barriers based on simulation and crash testing results, as shown in Figure 5.

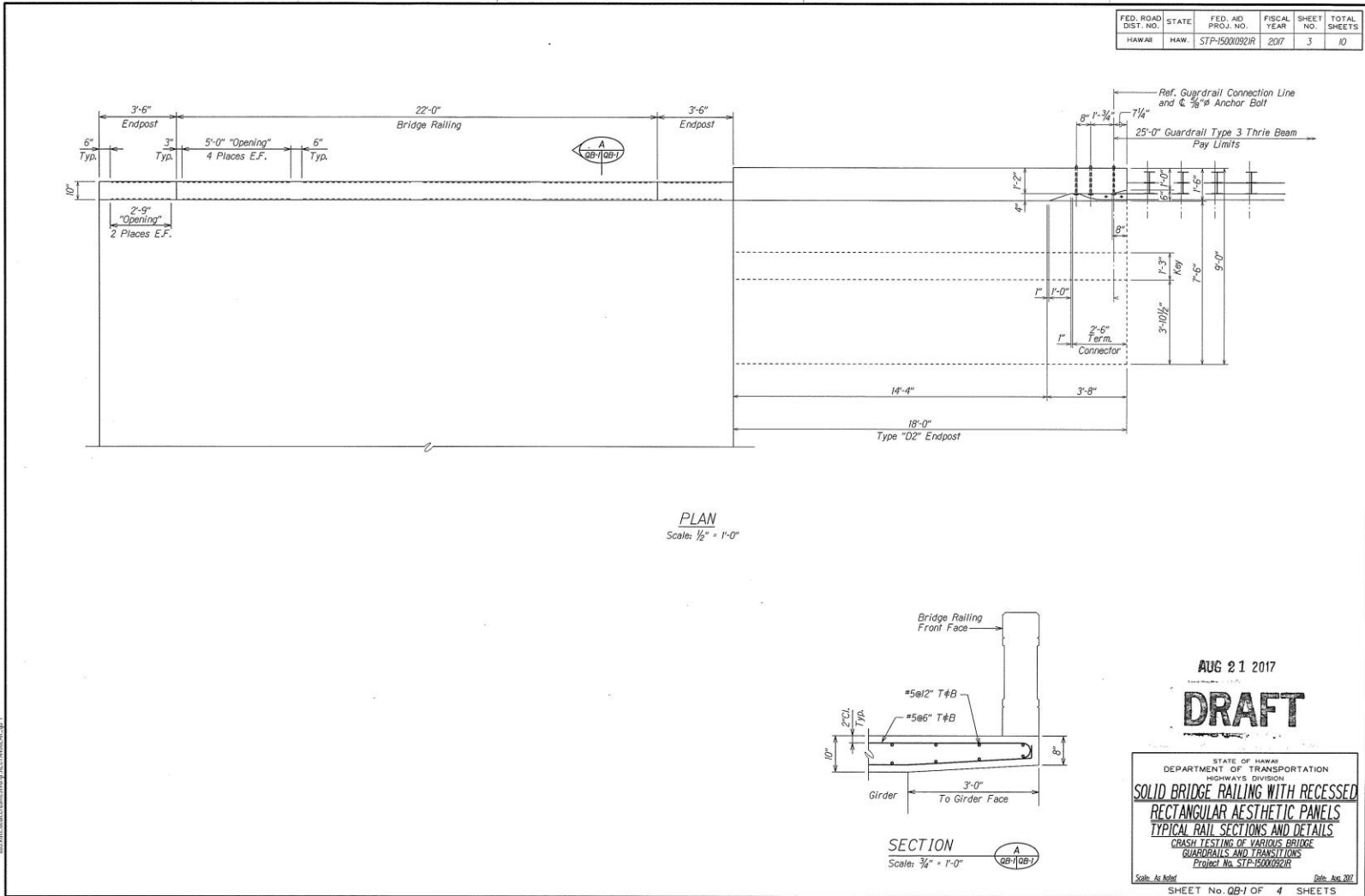

Figure 1. HDOT Standard Detail for the 34-in. Tall, Aesthetic Concrete Bridge Rail

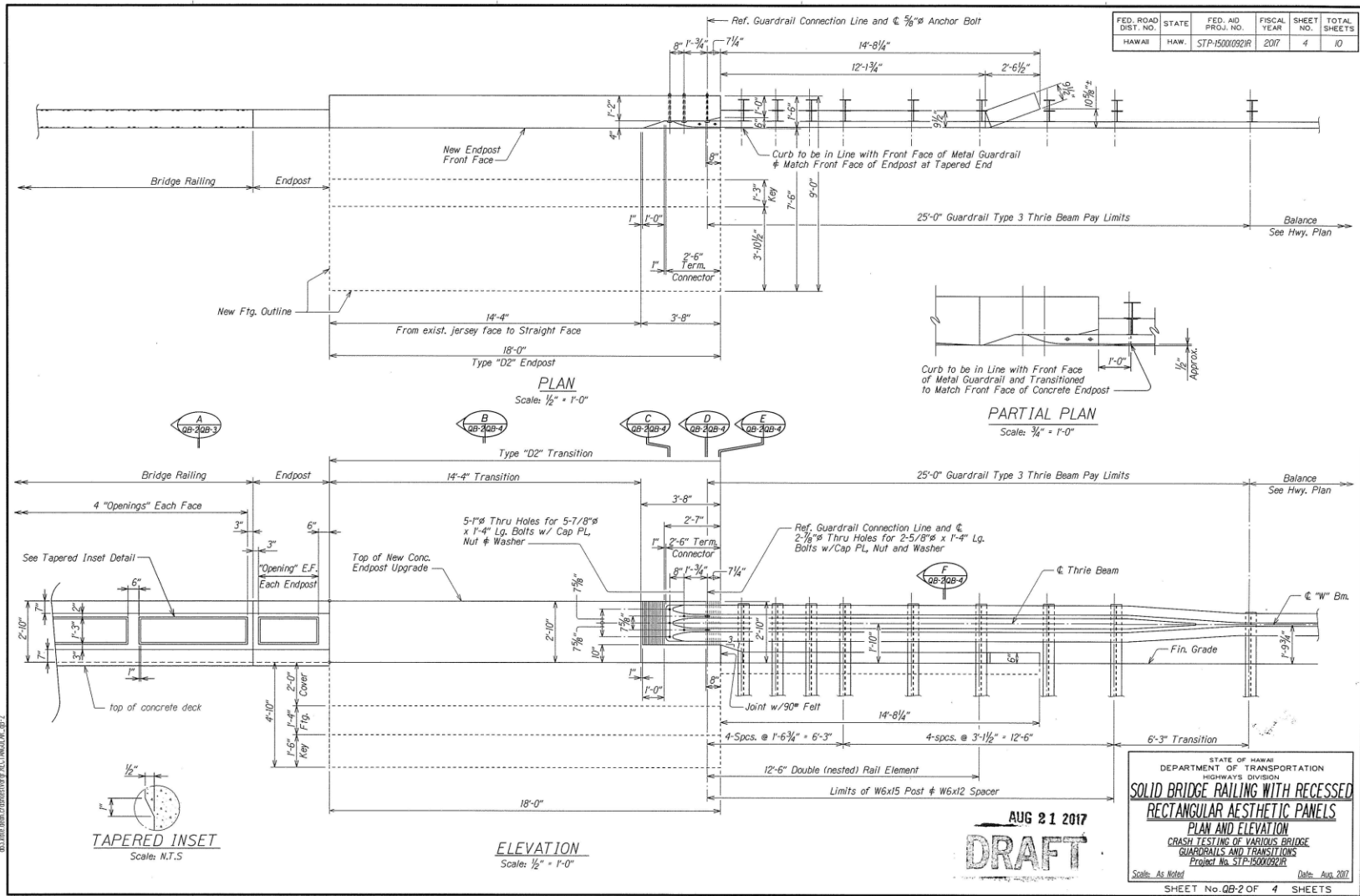
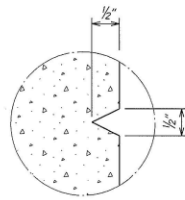
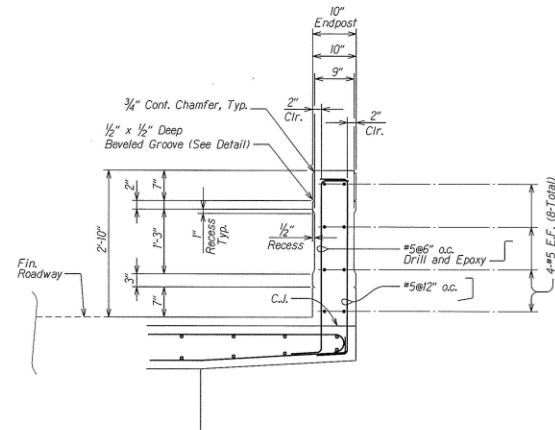

Figure 2. HDOT Standard Detail for the 34-in. Tall, Aesthetic Concrete Bridge Rail

FED. ROAD DIST. NO.	STATE	FISCAL YEAR	SHEET NO.	TOTAL SHEETS
HAWAII	HAW.	STP-1500092/R	2017	5



TYPICAL BEVELED GROOVE DETAIL
Scale: N.T.S.



SECTION A
Scale: 1" = 1'-0"

TYPICAL SECTIONS - RAIL DETAILS

AUG 21 2017
DRAFT

STATE OF HAWAII
DEPARTMENT OF TRANSPORTATION
HIGHWAYS DIVISION
**SOLID BRIDGE RAILING WITH RECESSED
RECTANGULAR AESTHETIC PANELS**
TYPICAL RAIL SECTIONS AND DETAILS
CRASH TESTING OF VARIOUS BRIDGE
GUARDRAILS AND TRANSITIONS
Project No. STP-1500092/R
Scale: As Noted Date: Aug. 2017
SHEET No. 08-3 OF 4 SHEETS

DESIGNED BY	DATE
DRAWN BY	
CHECKED BY	
APPROVED BY	

Figure 3. HDOT Standard Detail for the 34-in. Tall, Aesthetic Concrete Bridge Rail

FED. ROAD DIST. NO.	STATE	FED. AID PROJ. NO.	FISCAL YEAR	SHEET NO.	TOTAL SHEETS
HAWAII	HAW.	STP-15000921R	2017	6	10

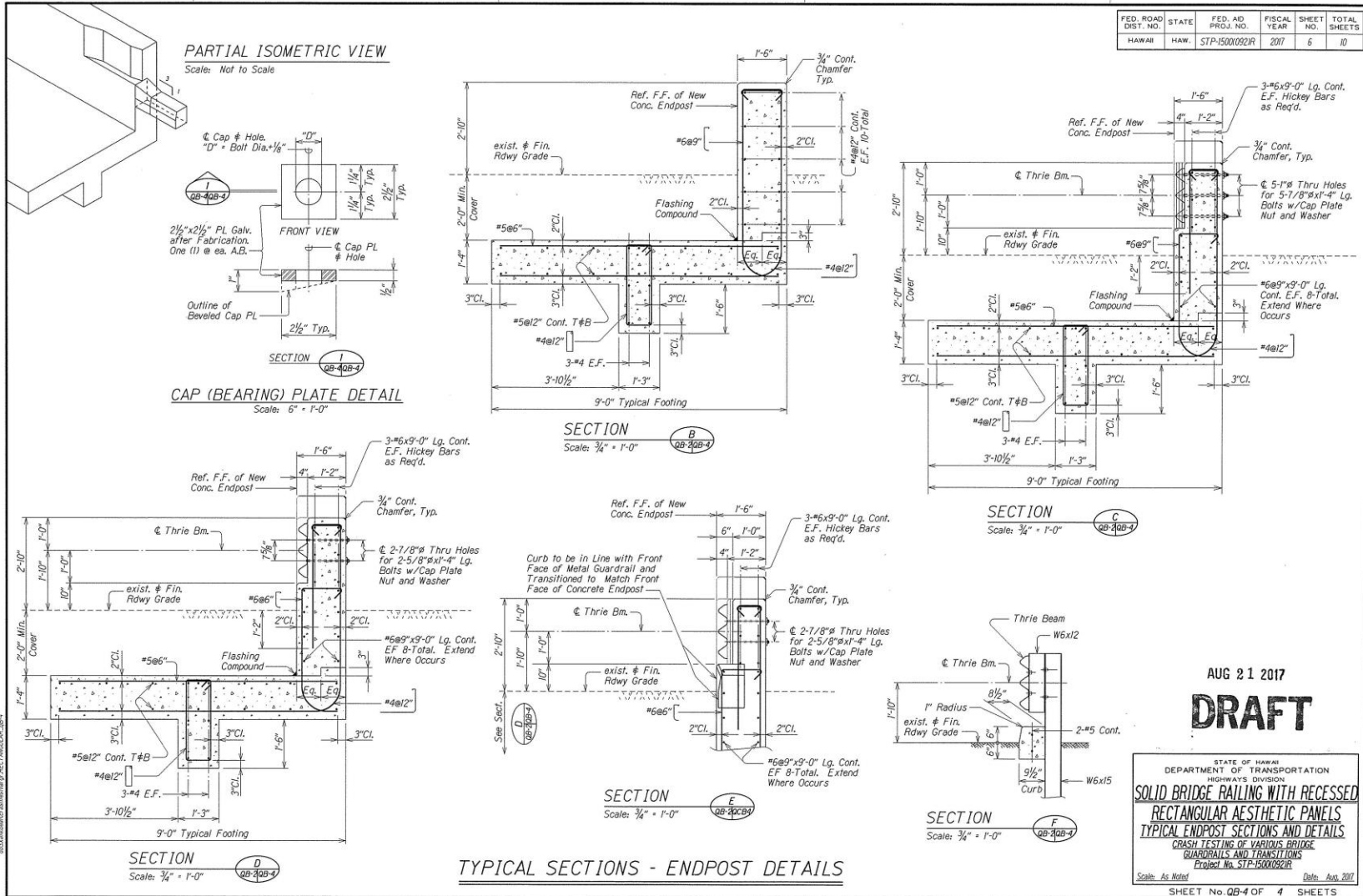

5

Figure 4. HDOT Standard Detail for the 34-in. Tall, Aesthetic Concrete Bridge Rail

October 21, 2019
MWRSF Report No. TRP-03-420-19

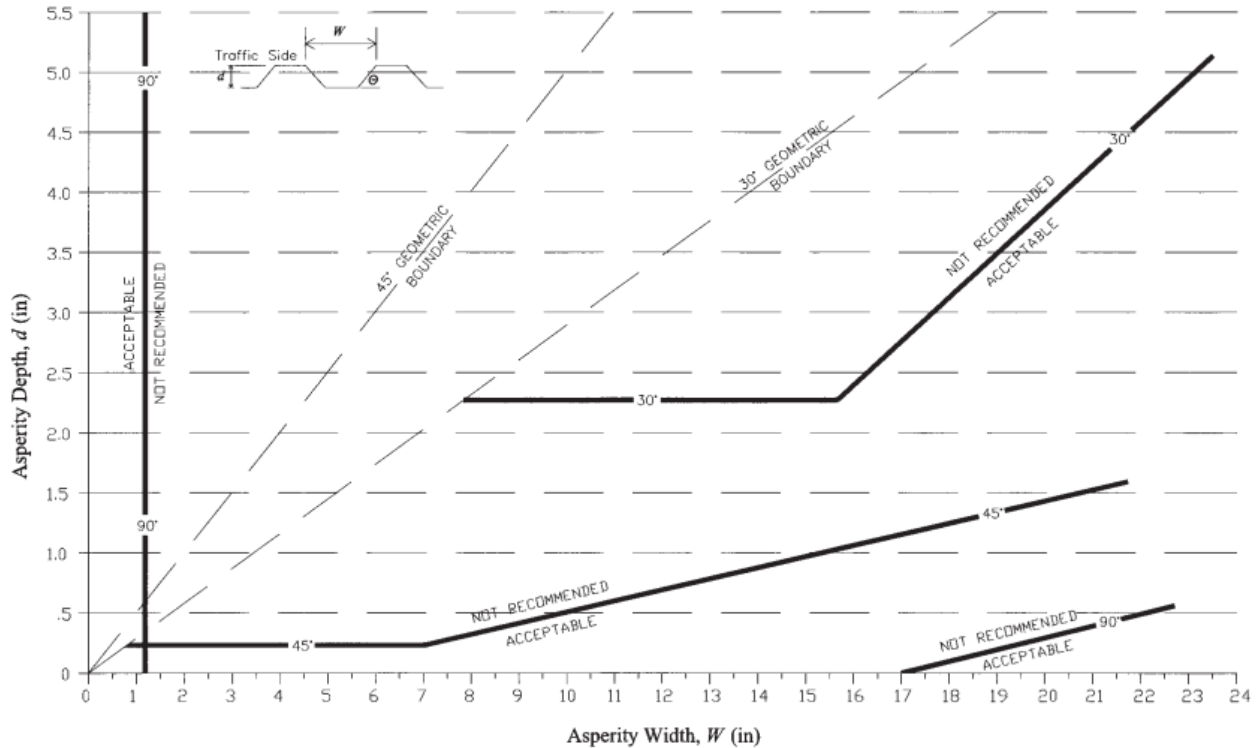

Figure 5. Final Design Guidelines for Aesthetic Surface Treatments of Safety Shape Concrete Barrier [1]

NCHRP Report No. 554 also provided guidelines for single-sloped and vertical-face barriers that were developed by the California Department of Transportation (Caltrans) [2] in 2002 and approved by the Federal Highway Administration (FHWA) in acceptance letter B-110. Caltrans conducted crash testing on single-sloped barriers with various architectural treatments in order to develop guidelines for evaluating crashworthiness of barriers with wide-ranging patterns and textures. Six recommendations for single-sloped or vertical-face barriers were developed after full-scale crash testing in accordance with NCHRP Report No. 350 Test Level 3 (TL-3) [3] criteria. As reported in NCHRP Report No. 554, the following types of surface treatment are permitted:

1. Sandblasted textures with a maximum relief of 9.5 mm.
2. Images or geometric patterns cut into the face of the barrier 25 mm or less and having 45-degree or flatter chamfered or beveled edges to minimize vehicular sheet metal or wheel snagging.
3. Textures or patterns of any shape and length inset into the face of the barrier up to 13 mm deep and 25 mm wide.
4. Any pattern or texture with gradual undulation that has a maximum relief of 20 mm over a distance of 300 mm.
5. Gaps, slots, grooves, or joints of any depth with a maximum width of 20 mm and a maximum surface differential across these features of 5 mm.

6. Any pattern or texture with a maximum relief of 64 mm, if such a pattern begins 610 mm or more above the base of the barrier and if all leading edges are rounded or sloped to minimize any vehicle snagging potential.

After comparing the HDOT 34-in. tall, Aesthetic Concrete Bridge Rail to the NCHRP Report No. 554 design guidelines, the research team anticipated that existing bridge rail would likely provide acceptable safety performance under current impact safety standards for passenger vehicles. However, full-scale crash testing was needed to evaluate the bridge rail to the safety criteria in the American Association of State Highway and Transportation (AASHTO) *Manual for Assessing Safety Hardware, Second Edition* (MASH 2016) [4].

1.2 Objective

The objective of this report included a safety performance evaluation of the length-of-need (LON) of HDOT's 34-in. tall, Aesthetic Concrete Bridge Rail system. The system was evaluated according to TL-3 criteria found MASH 2016.

1.3 Scope

The research objective was achieved through the completion of several tasks. Two full-scale crash tests were conducted on the HDOT 34-in. tall, Aesthetic Concrete Bridge Rail according to MASH 2016 test designation nos. 3-10 and 3-11. Next, the full-scale vehicle crash test results were analyzed, evaluated, and documented. Conclusions and recommendations were then made pertaining to the safety performance of the HDOT 34-in. tall, Aesthetic Concrete Bridge Rail system. A final report was published discussing the results and findings from two full-scale crash tests that were conducted on the HDOT 34-in. tall, Aesthetic Concrete Bridge Rail.

2 TEST REQUIREMENTS AND EVALUATION CRITERIA

2.1 Test Requirements

Aesthetic concrete bridge rails must satisfy impact safety standards in order to be declared eligible for federal reimbursement by the FHWA for use on the National Highway System (NHS). For new hardware, these safety standards consist of the guidelines and procedures published in MASH 2016 [4]. Note that there is no difference between MASH 2009 [5] and MASH 2016 for longitudinal barriers (i.e., bridge rails), except that additional occupant compartment deformation measurements, photographs, and documentation are required by MASH 2016. According to TL-3 of MASH 2016, longitudinal barriers must be subjected to two full-scale vehicle crash tests, as summarized in Table 1. Note that both prescribed full-scale crash tests, test designation nos. 3-10 and 3-11, were conducted and reported herein, along with an evaluation of the bridge railing system.

It should be noted that the test matrix detailed herein represents a practical worst-case condition with respect to the MASH 2016 safety requirements and a crashworthiness evaluation of the barrier system. According to MASH 2016, the HDOT 34-in. tall, Aesthetic Concrete Bridge Rail should be evaluated at a location that evaluates the greatest propensity for vehicle snag as well as a location that maximizes structural loading of the bridge rail at a critical section. For the HDOT 34-in. tall, Aesthetic Concrete Bridge Rail, the critical impact point for both impact locations occur upstream from the expansion joint in the bridge rail. The HDOT 34-in. tall, Aesthetic Concrete Bridge Rail has a transition from the recessed panel to the main face of the bridge rail 2¾ in. upstream from the expansion joint in the rail. Thus, impacting upstream from this point provides an evaluation of vehicle snag on both the recessed panel edge and the expansion joint. Additionally, the critical structural section in the rail is at the expansion joint because the bridge rail design does not reduce the transverse reinforcement near the expansion joint and smooth dowel bars are used to transfer shear loading across the opening. As such, the critical impact point specified test designation nos. 3-10 and 3-11 for rigid barrier testing in Table 2.7 of MASH 2016 were applied upstream from the expansion joint for the evaluation of vehicle snag and structural loading of the HDOT 34-in. tall, Aesthetic Concrete Bridge Rail.

Table 1. MASH 2016 TL-3 Crash Test Conditions for Longitudinal Barriers

Test Article	Test Designation No.	Test Vehicle	Vehicle Weight, lb	Impact Conditions		Evaluation Criteria ¹
				Speed, mph	Angle, deg.	
Longitudinal Barrier	3-10	1100C	2,420	62	25	A,D,F,H,I
	3-11	2270P	5,000	62	25	A,D,F,H,I

¹ Evaluation criteria explained in Table 2.

Table 2. MASH 2016 Evaluation Criteria for Longitudinal Barriers

Structural Adequacy	A. Test article should contain and redirect the vehicle or bring the vehicle to a controlled stop; the vehicle should not penetrate, underride, or override the installation although controlled lateral deflection of the test article is acceptable.		
Occupant Risk	D. Detached elements, fragments, or other debris from the test article should not penetrate or show potential for penetrating the occupant compartment, or present an undue hazard to other traffic, pedestrians, or personnel in a work zone. Deformations of, or intrusions into, the occupant compartment should not exceed limits set forth in Section 5.2.2 and Appendix E of MASH 2016.		
	F. The vehicle should remain upright during and after collision. The maximum roll and pitch angles are not to exceed 75 degrees.		
	H. Occupant Impact Velocity (OIV) (see Appendix A, Section A5.2.2 of MASH 2016 for calculation procedure) should satisfy the following limits:		
	Occupant Impact Velocity Limits		
	Component	Preferred	Maximum
	Longitudinal and Lateral	30 ft/s	40 ft/s
Occupant Risk	I. The Occupant Ridedown Acceleration (ORA) (see Appendix A, Section A5.2.2 of MASH 2016 for calculation procedure) should satisfy the following limits:		
	Occupant Ridedown Acceleration Limits		
	Component	Preferred	Maximum
	Longitudinal and Lateral	15.0 g's	20.49 g's

2.2 Evaluation Criteria

Evaluation criteria for full-scale vehicle crash testing are based on three appraisal areas: (1) structural adequacy; (2) occupant risk; and (3) vehicle trajectory after collision. Criteria for structural adequacy are intended to evaluate the ability of the HDOT 34-in. tall, Aesthetic Concrete Bridge Rail to contain and safely redirect impacting vehicles. In addition, controlled lateral deflection of the test article is acceptable. Occupant risk evaluates the degree of hazard to occupants in the impacting vehicle. Post-impact vehicle trajectory is a measure of the potential of the vehicle to result in a secondary collision with other vehicles and/or fixed objects, thereby increasing the risk of injury to the occupants of the impacting vehicle and/or other vehicles. These evaluation criteria are summarized in Table 2 and defined in greater detail in MASH 2016. The full-scale vehicle crash tests documented herein were conducted and reported in accordance with the procedures provided in MASH 2016.

In addition to the standard occupant risk measures, the Post-Impact Head Deceleration (PHD), the Theoretical Head Impact Velocity (THIV), and the Acceleration Severity Index (ASI) were determined and reported. Additional discussion on PHD, THIV, and ASI is provided in MASH 2016.

3 DESIGN DETAILS

The test installation consisted of two 11-ft long and three 22-ft long concrete barrier segments, as shown in Figures 6 through 14. Photographs of the test installation are shown in Figures 15 through 17. Material specifications, mill certifications, and certificates of conformity for the system materials are shown in Appendix A.

As noted previously, the HDOT 34-in. tall, Aesthetic Concrete Bridge Rail was fabricated for evaluation of the LON of the bridge rail. Thus, no end sections of the rail were constructed. The rail was constructed in five segments separated by four expansion joints to allow for evaluation of the critical rail section at the expansion joints. The spacing between the expansion joints was limited to 22 ft, which was the smallest rail segment length between joints noted by HDOT. Larger rail segment lengths between expansion joints were considered less critical. The HDOT 34-in. tall, Aesthetic Concrete Bridge Rail was installed on the concrete tarmac at the MwRSF Outdoor Test Site rather than on a simulated bridge deck and overhang. Previous testing of a MASH 2016 TL-4 bridge rail on similar 8-in. thick concrete bridge deck displayed no deck damage [6], which indicated that the potential for deck damage or deflection that would affect the outcome of the full-scale crash of the HDOT 34-in. tall, Aesthetic Concrete Bridge Rail was minimal under MASH 2016 TL-3 impact conditions. However, the HDOT 34-in. tall, Aesthetic Concrete Bridge Rail was constructed in a trench such that the back of the rail was 36 in. tall relative to the tarmac to simulate the correct height of the rail relative to the bridge deck in the HDOT standard. A concrete fill was then applied to the trench in front of the traffic-side face of the rail to simulate the 2-in. tall finished grade used by HDOT.

The bridge rail was 34 in. tall relative to the traffic-side tarmac and 10 in. wide at the top and the bottom. The top surface had $\frac{3}{4}$ -in. chamfered edges. Recessed aesthetic lines $\frac{1}{2}$ in. deep were located 7 in. below the top surface and 9 in. above the bottom surface on the traffic- and back-side faces. The main aesthetic feature on this concrete bridge rail was 60-in. wide x 15-in. tall x $\frac{1}{2}$ -in. deep recessed panels on both the traffic-side and back-side faces. The edges of the panels transitioned to the face of the rail using 2H:1V slope. The concrete mix for the bridge rail sections required a minimum 28-day compressive strength of 4,000 psi. Two concrete cylinder compression tests were conducted, with 13-day compressive strength results of 4,000 psi and 4,260 psi. Steel reinforcement in the barrier consisted of ASTM A615 Grade 60 rebar. Each concrete bridge rail segment consisted of eight no. 5 longitudinal bars (four per face) that were vertically spaced 10 in. apart. Vertical stirrups were also provided using no. 5 rebar, which were spaced on 12-in. centers on the back-side face and on 6-in. centers on the traffic-side face. Vertical reinforcement bars were anchored to an existing concrete tarmac on both the traffic-side and back-side faces to a depth of 8 in. and epoxied with Hilti HIT RE-500 V3 in order to develop the full tensile strength of the bar. The minimum bond strength of the epoxy adhesive was 1,560 psi after a two-day cure.

The bridge rail system contained an expansion joint consisting of a $\frac{1}{2}$ -in. gap that was filled by expansion joint sealant, as shown in Figures 8 and 9. The expansion joint assembly consisted of three 24-in. long, no. 8 smooth rebar with PVC tubes and caps casted on the upstream side of the expansion joint. Additional vertical stirrups spaced on 4-in. centers were placed at the expansion joints, as shown in Figures 8 and 9.

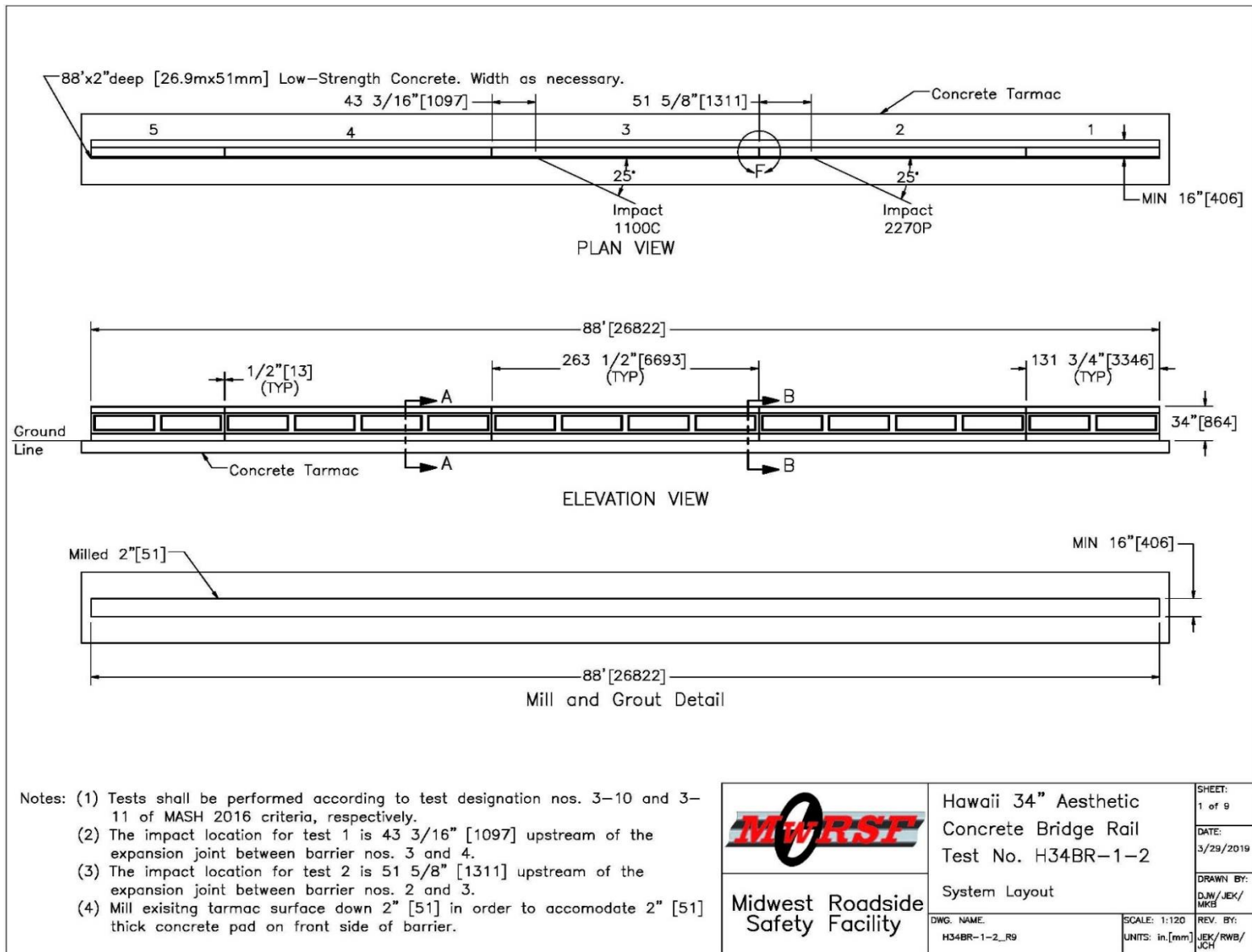

Figure 6. Test Installation Layout, Test Nos. H34BR-1 and H34BR-2

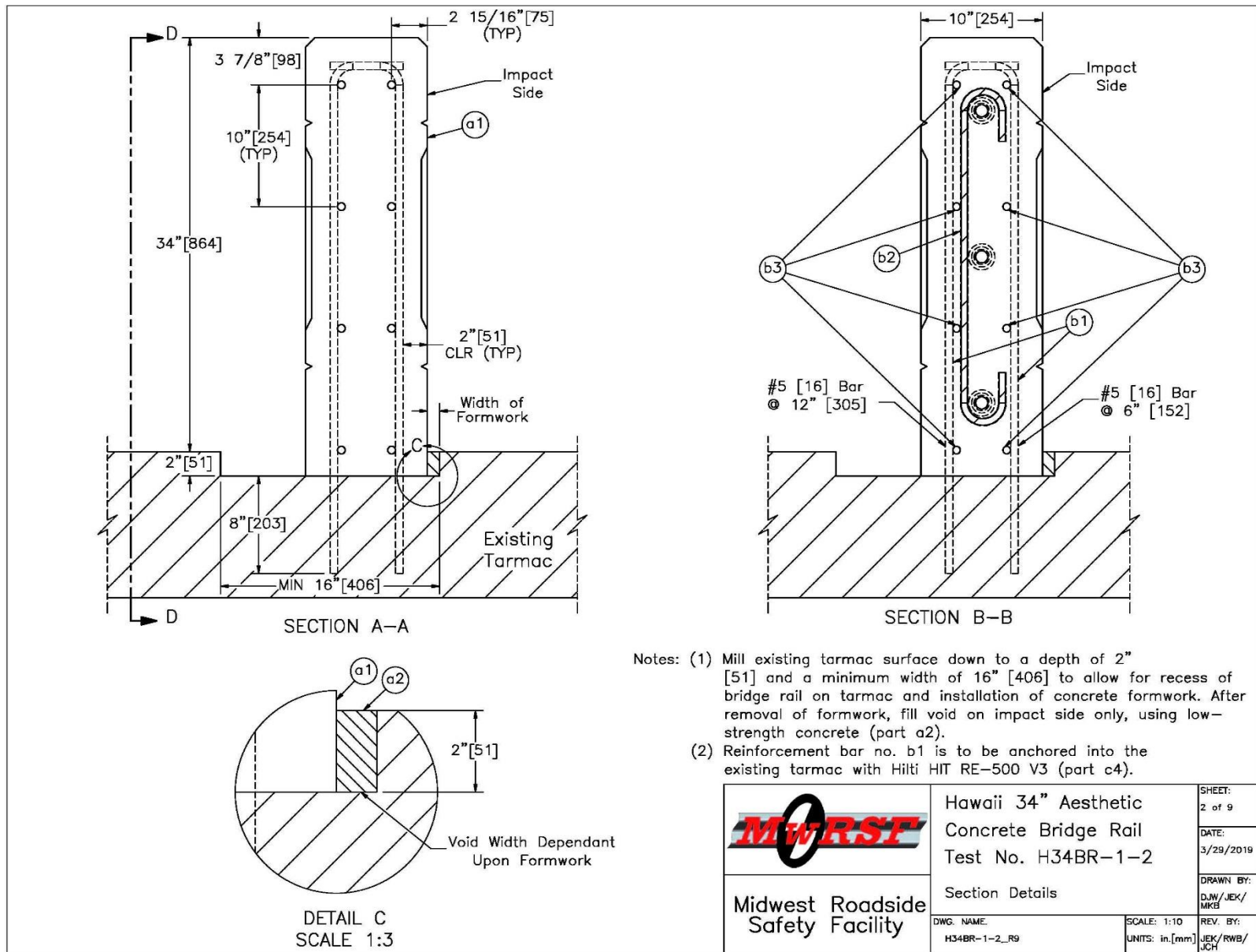

Figure 7. Section Details, Test Nos. H34BR-1 and H34BR-2

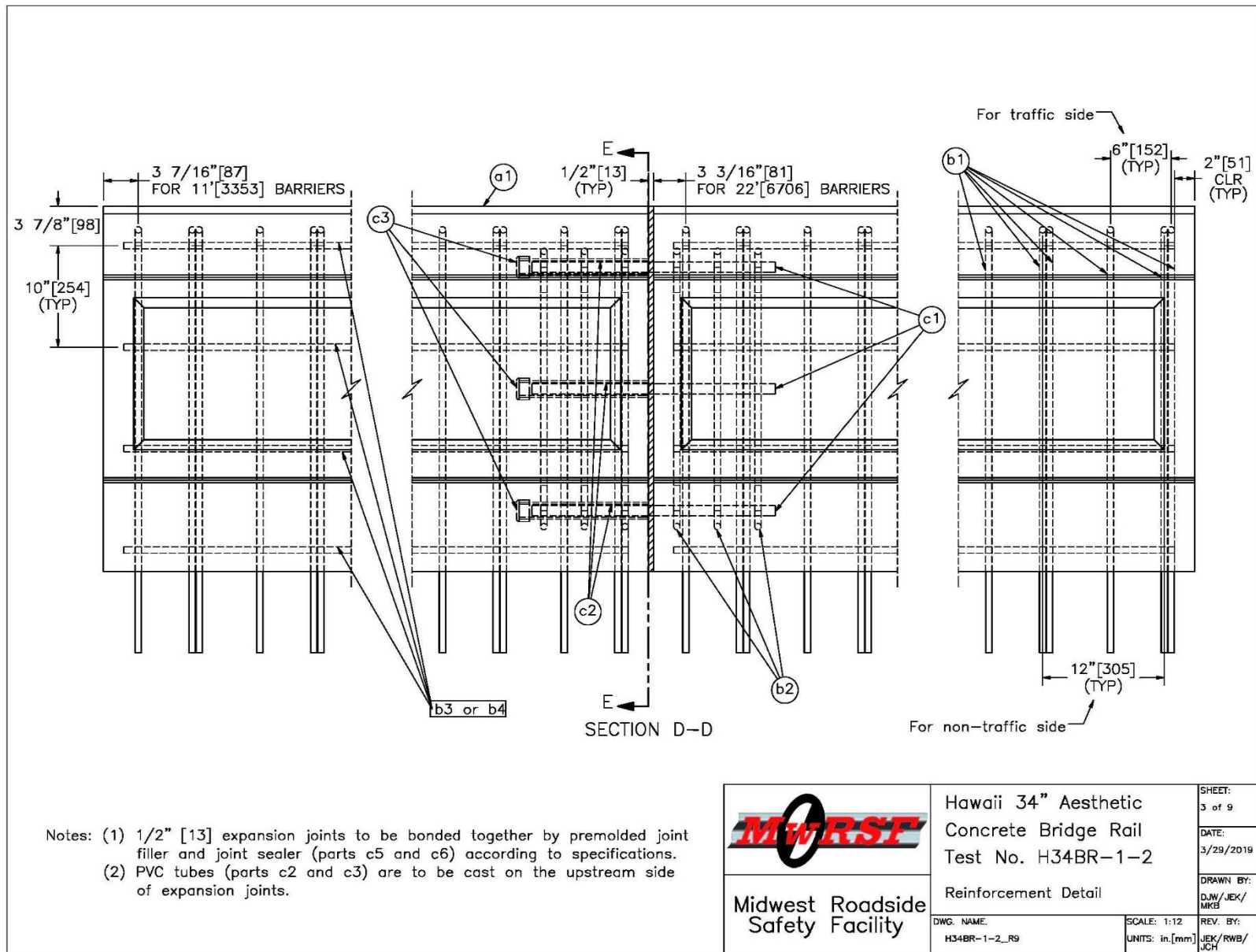

Figure 8. Reinforcement Detail, Test Nos. H34BR-1 and H34BR-2

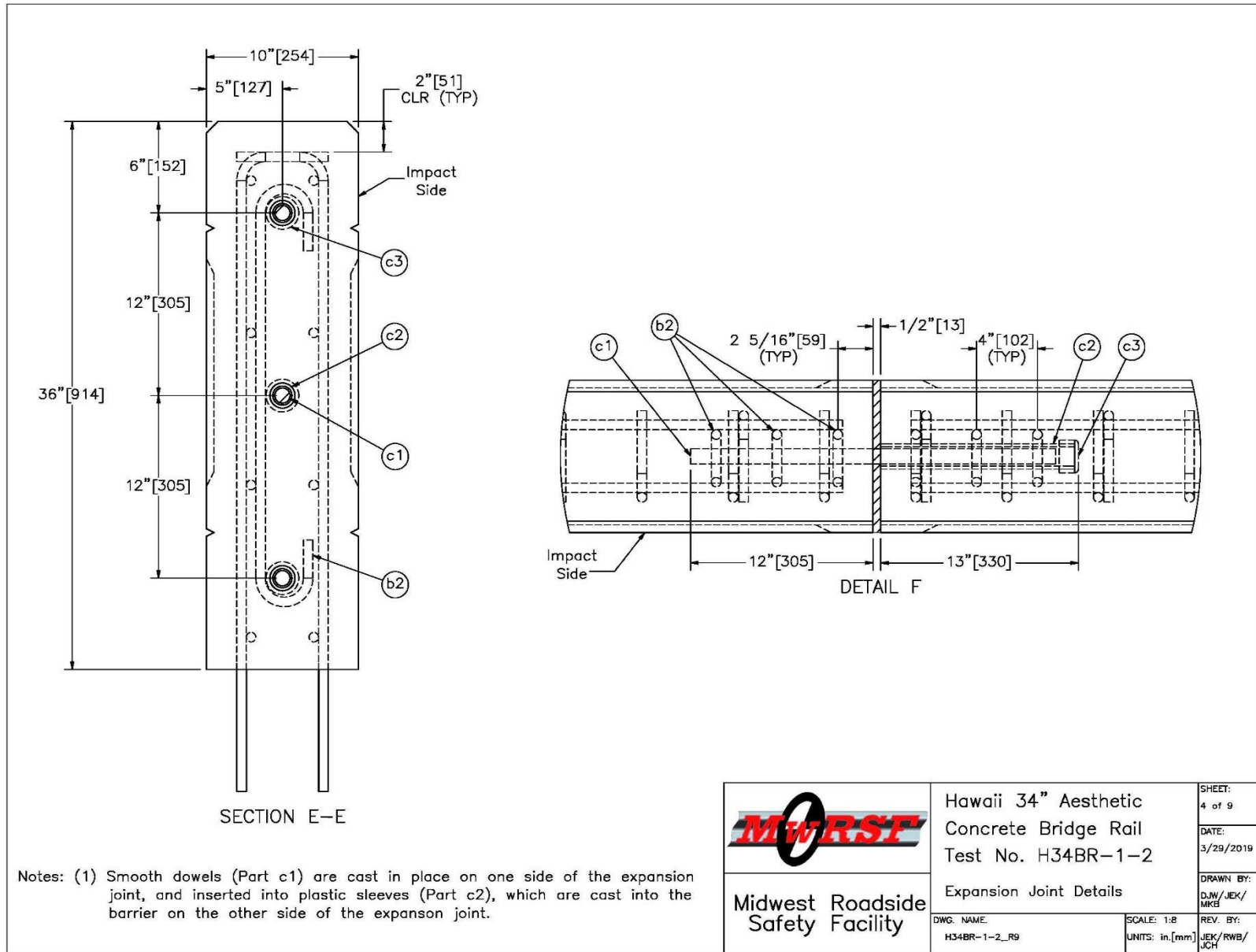

Figure 9. Expansion Joint Details, Test Nos. H34BR-1 and H34BR-2

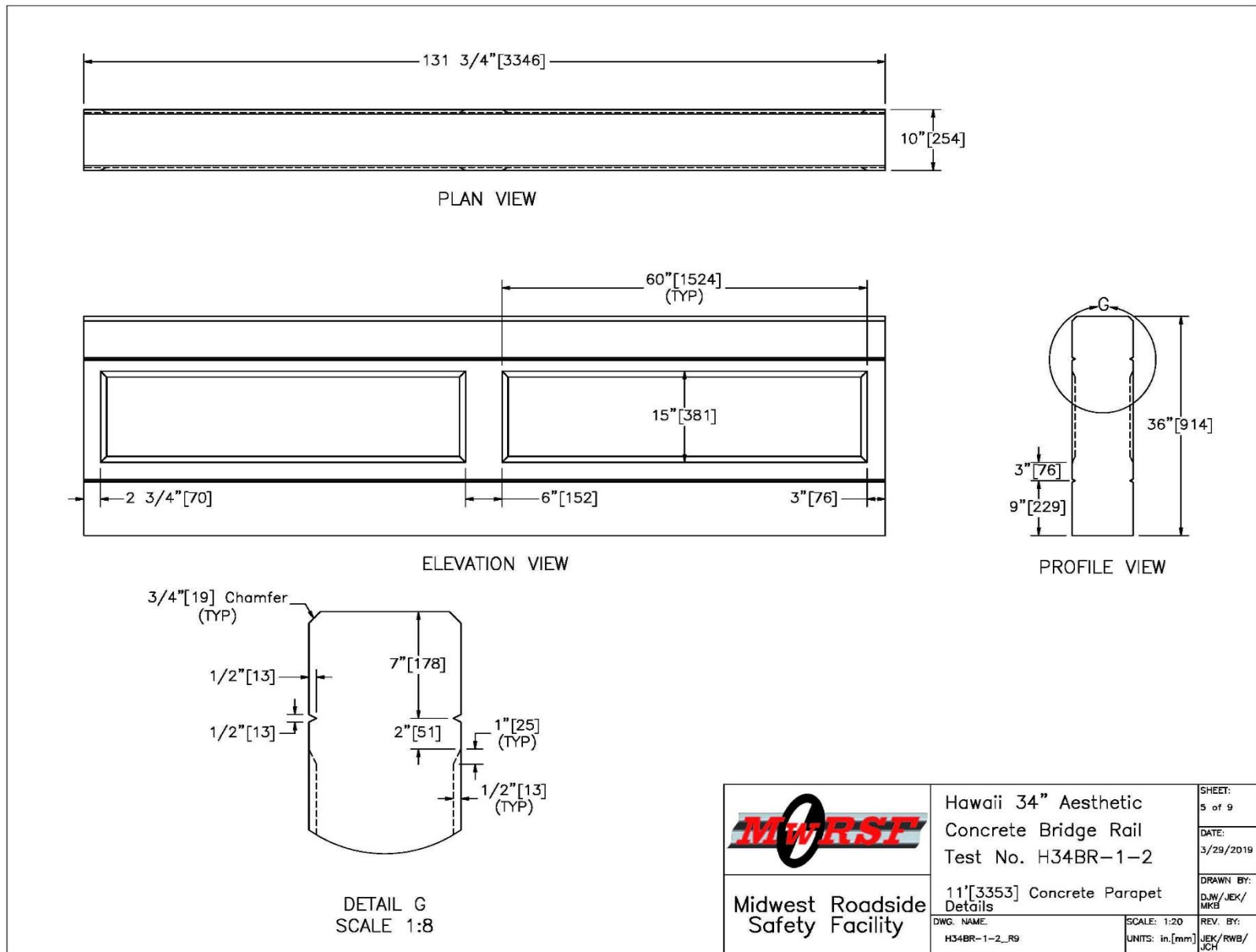

Figure 10. 11-ft Concrete Parapet Details, Test Nos. H34BR-1 and H34BR-2

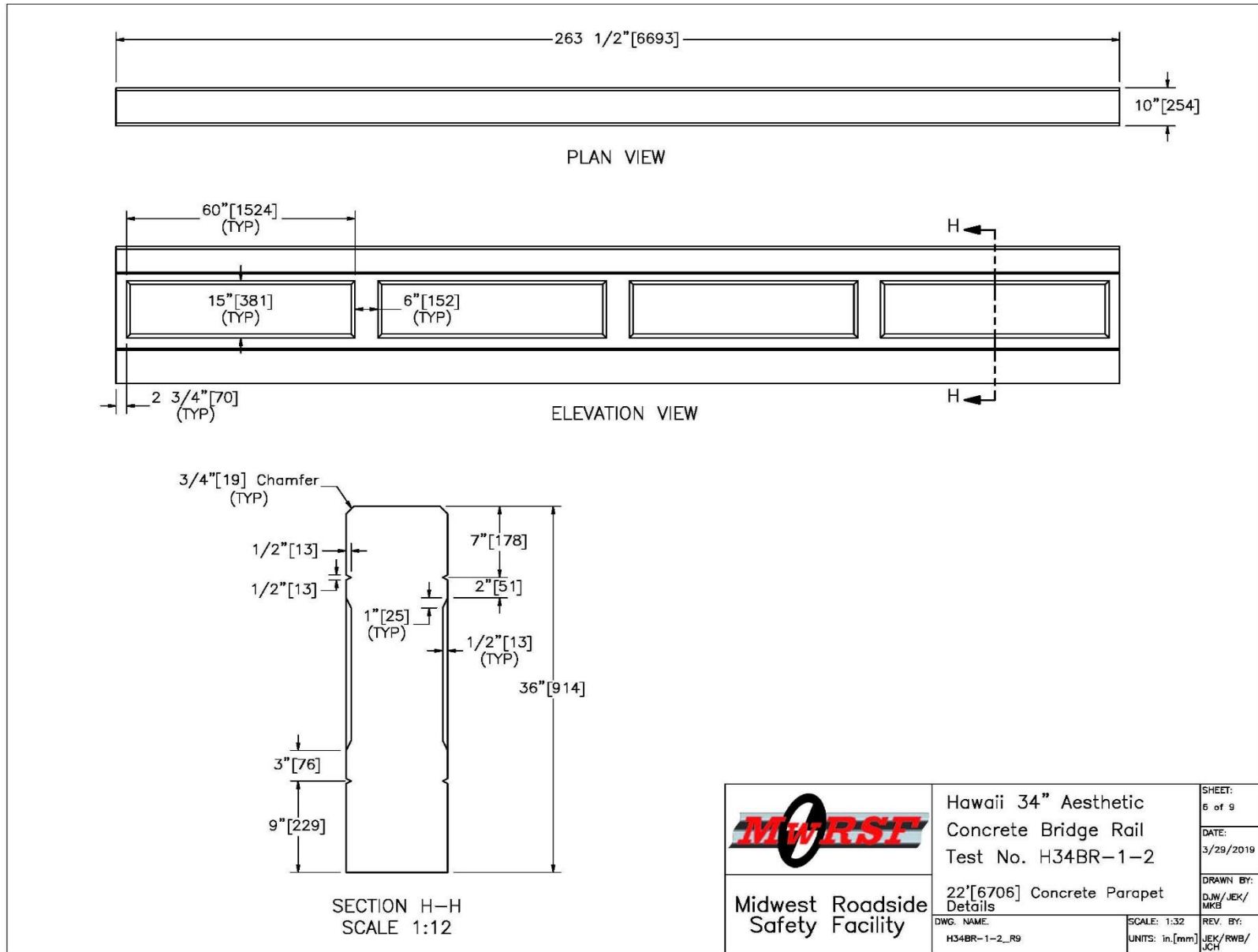

Figure 11. 22-ft Concrete Parapet Details, Test Nos. H34BR-1 and H34BR-2

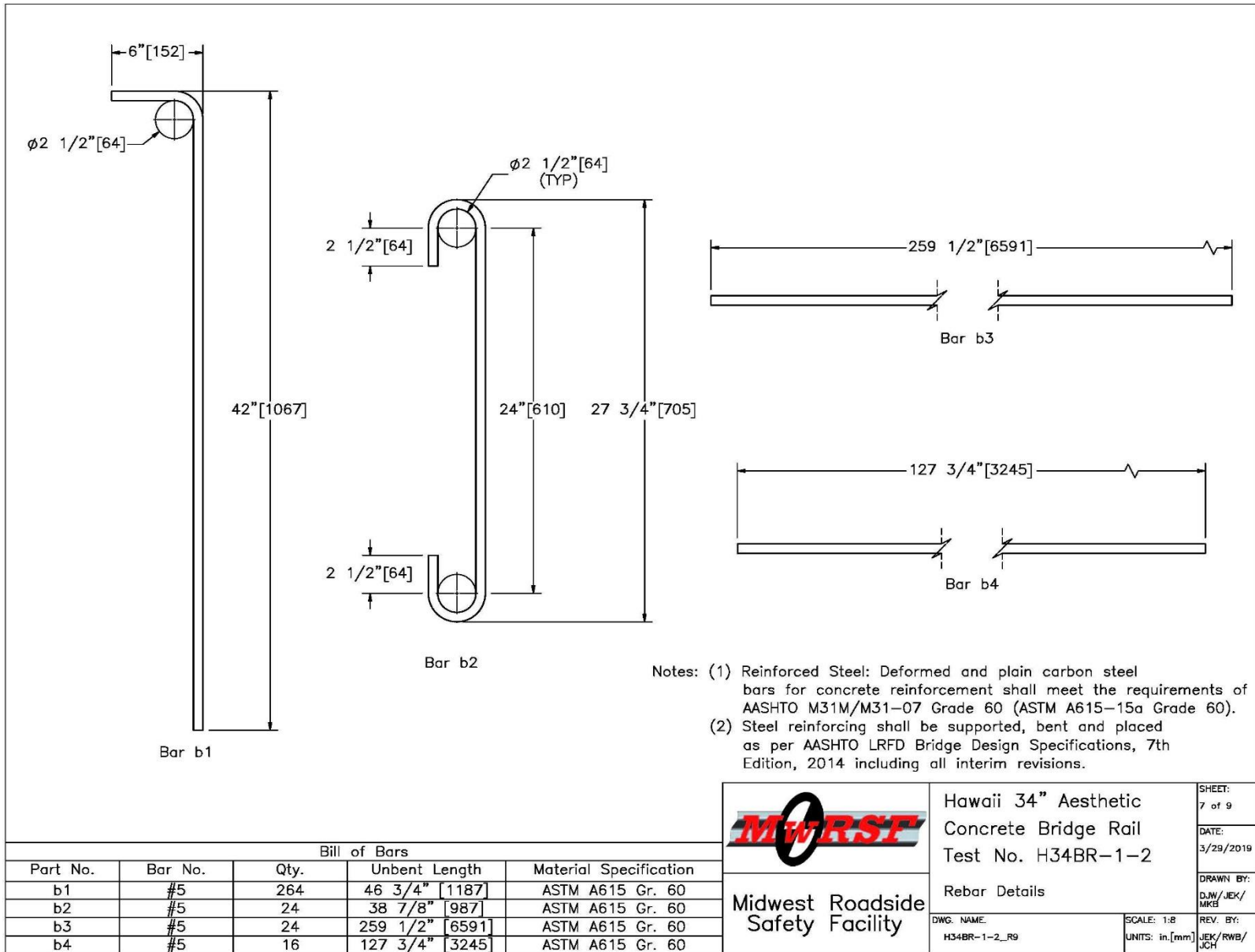

Figure 12. Rebar Details, Test Nos. H34BR-1 and H34BR-2

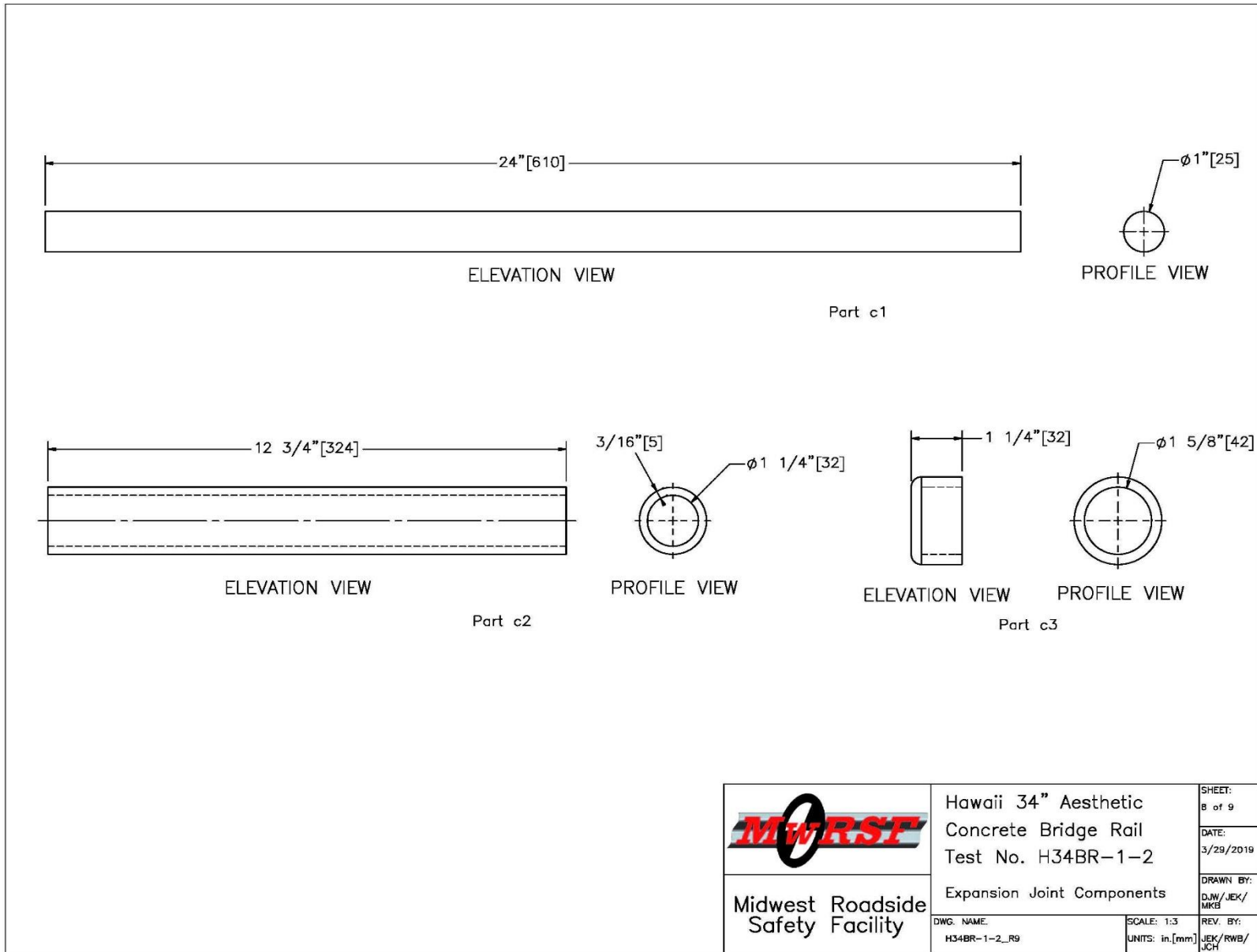

Figure 13. Expansion Joint Components, Test Nos. H34BR-1 and H34BR-2

Item No.	QTY.	Description	Material Specification	Treatment Specification
a1	-	Reinforced Concrete	Min. f'c = 4,000 psi [27.6 MPa] NE Mix 47BD	-
a2	-	Low-Strength Concrete Overlay	Concrete NE Mix 9019 CITY	-
b1	264	#5 [16] Rebar, 46 3/4" [1187] Total Unbent Length	ASTM A615 Gr. 60	Epoxy Coated (ASTM A775 or A934)*
b2	24	#5 [16] Rebar, 38 7/8" [987] Total Unbent Length	ASTM A615 Gr. 60	Epoxy Coated (ASTM A775 or A934)*
b3	24	#5 [16] Rebar, 259 1/2" [6591] Total Length	ASTM A615 Gr. 60	Epoxy Coated (ASTM A775 or A934)*
b4	16	#5 [16] Rebar, 127 3/4" [3245] Total Length	ASTM A615 Gr. 60	Epoxy Coated (ASTM A775 or A934)*
c1	12	#8 [25] Smooth Rebar, 24" [288] Total Length	ASTM A615 Gr. 60	Epoxy Coated (ASTM A775 or A934)*
c2	12	1 1/4" [32] Dia. PVC Pipe	Schedule 80 PVC Gr. 12454	-
c3	12	1 1/4" [32] PVC Cap	Schedule 80 PVC Gr. 12454	-
c4	-	Epoxy Adhesive	Hilti HIT RE-500 V3	-
c5	-	Expansion Joint Filler	AASHTO M33, M153, or M213	-
c6	-	Expansion Joint Sealant	AASHTO M173, M282, M301, ASTM D3581, or ASTM D5893	-

*Rebar does not need to be epoxy-coated for testing purposes.

 Midwest Roadside Safety Facility	Hawaii 34" Aesthetic Concrete Bridge Rail Test No. H34BR-1-2	SHEET: 9 of 9
	Bill of Materials	DATE: 3/29/2019
DWG. NAME: H34BR-1-2_R9	SCALE: None UNITS: in./mm	DRAWN BY: DJW/JEK/ MKB
		REV. BY: JEK/RWB/ UCH

Figure 14. Bill of Materials, Test Nos. H34BR-1 and H34BR-2



Figure 15. Test Installation Photographs, Test Nos. H34BR-1 and H34BR-2

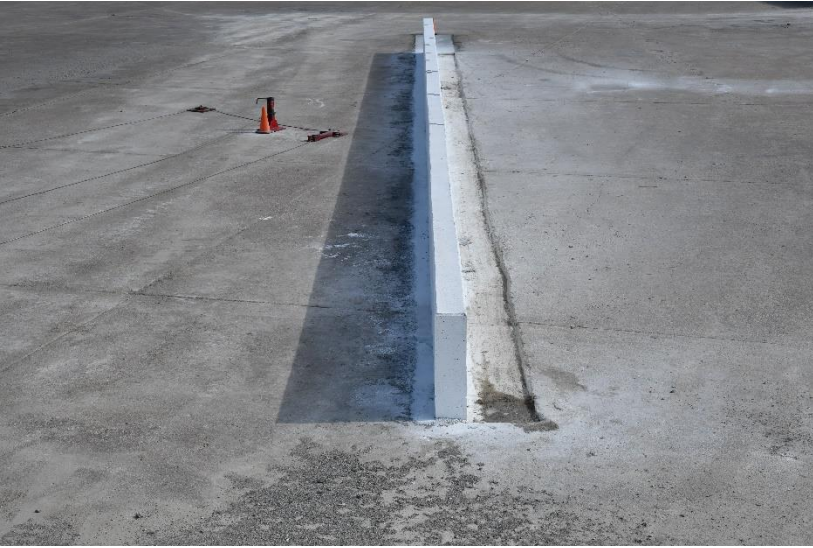

Figure 16. Test Installation Photographs, Back Side, Test Nos. H34BR-1 and H34BR-2



Figure 17. Test Installation Photographs, Traffic Side, Test Nos. H34BR-1 and H34BR-2

4 TEST CONDITIONS

4.1 Test Facility

The Outdoor Test Site is located at the Lincoln Air Park on the northwest side of the Lincoln Municipal Airport and is approximately 5 miles northwest of the University of Nebraska-Lincoln.

4.2 Vehicle Tow and Guidance System

A reverse-cable, tow system with a 1:2 mechanical advantage was used to propel the test vehicles. The distance traveled and the speed of the tow vehicle were one-half that of the test vehicles. The test vehicles were released from the tow cable before impact with the barrier system. A digital speedometer on the tow vehicle increased the accuracy of the test vehicles' impact speed.

A vehicle guidance system developed by Hinch [7] was used to steer the test vehicles. A guide flag, attached to the left-front wheel for test nos. H34BR-1 and H34BR-2, and the guide cable were sheared off before impact with the barrier system. The $\frac{3}{8}$ -in. diameter guide cable was tensioned to approximately 3,500 lb and supported both laterally and vertically every 100 ft by hinged stanchions. The hinged stanchions stood upright while holding up the guide cable. As the vehicle was towed down the line, the guide flag struck and knocked each stanchion to the ground.

4.3 Test Vehicles

For test no. H34BR-1, a 2009 Hyundai Accent was used as the test vehicle. The curb, test inertial, and gross static vehicle weights were 2,511 lb, 2,430 lb, and 2,589 lb, respectively. The test vehicle is shown in Figures 18 and 19, and vehicle dimensions are shown in Figure 20. MASH 2016 describes that test vehicles used in crash testing should be no more than six model years old. The 2009 Hyundai Accent was used instead of the 2013 model for the crash test because the 2013 model vehicle geometry did not comply with the recommended vehicle dimension ranges specified in Table 4.1 in MASH 2016.



Figure 18. Test Vehicle, Test No. H34BR-1

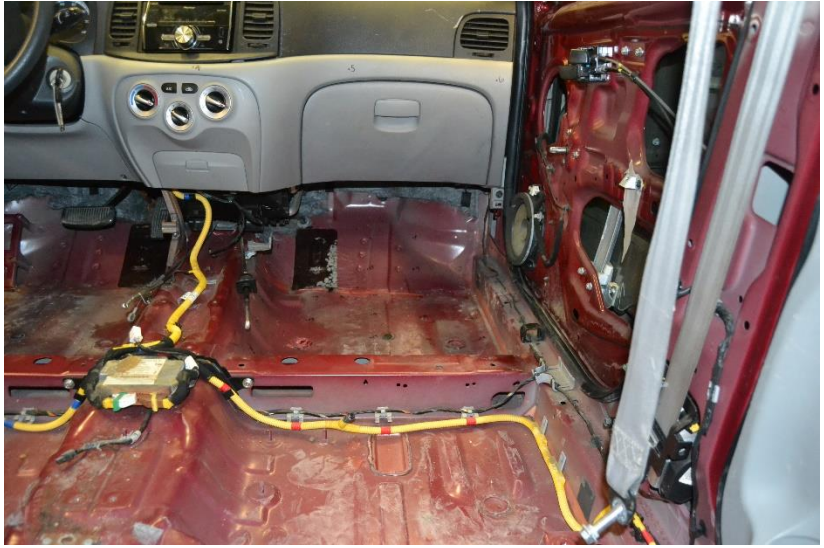

Figure 19. Test Vehicle's Interior Floorboards and Undercarriage, Test No. H34BR-1

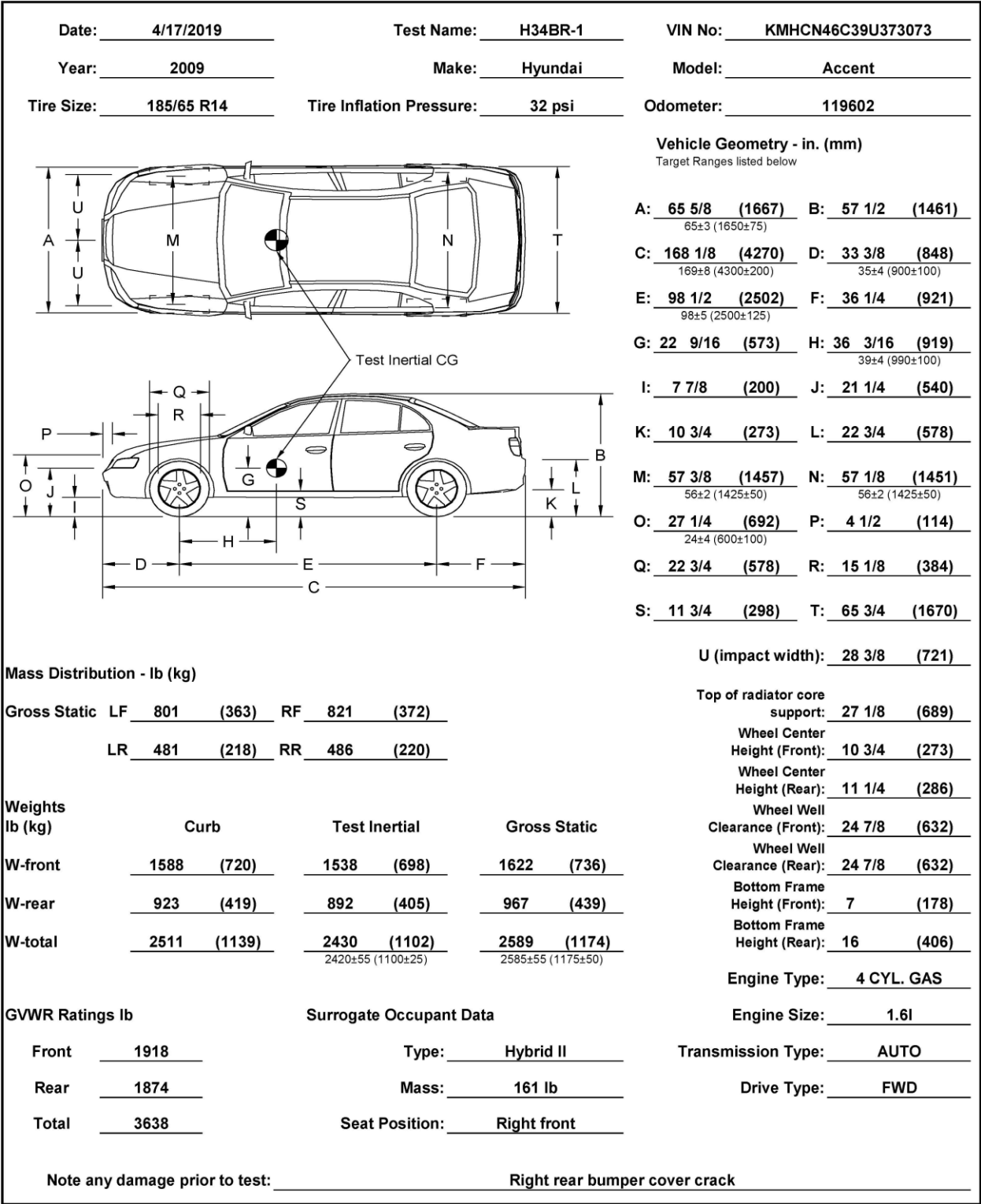

Figure 20. Vehicle Dimensions, Test No. H34BR-1

For test no. H34BR-2, a 2013 Dodge Ram 1500 quad cab pickup truck was used as the test vehicle. The curb, test inertial, and gross static vehicle weights were 5,068 lb, 5,001 lb, and 5,167 lb, respectively. The test vehicle is shown in Figures 21 and 22, and vehicle dimensions are shown in Figure 23.

The longitudinal component of the center of gravity (c.g.) was determined using the measured axle weights. The vertical component of the c.g. for the 1100C vehicle was determined utilizing a procedure published by SAE [8]. The location of the final c.g. for test no. H34BR-1 is shown in Figures 20 and 24. The Suspension Method [9] was used to determine the vertical component of the c.g. for the pickup truck. This method is based on the principle that the c.g. of any freely suspended body is in the vertical plane through the point of suspension. The vehicle was suspended successively in three positions, and the respective planes containing the c.g. were established. The intersection of these planes pinpointed the final c.g. location for the test inertial condition. The location of the final c.g. for test no. H34BR-2 is shown in Figures 23 and 25. Data used to calculate the location of the c.g. and ballast information are shown in Appendix B.

Square, black- and white-checked targets were placed on the vehicles for reference to be viewed from the high-speed digital video cameras and aid in the video analysis, as shown in Figures 24 and 25. Round, checkered targets were placed at the c.g. on the left-side door, the right-side door, and the roof of the vehicles.

The front wheels of the test vehicles were aligned to vehicle standards except the toe-in value was adjusted to zero such that the vehicles would track properly along the guide cable. A 5B flash bulb was mounted under both vehicles' right windshield wiper and was fired by a pressure tape switch mounted at the impact corner of the bumper. The flash bulb was fired upon initial impact with the test article to create a visual indicator of the precise time of impact on the high-speed digital videos. A remote-controlled brake system was installed in the test vehicles so the vehicles could be brought safely to a stop after the test.



Figure 21. Test Vehicle, Test No. H34BR-2

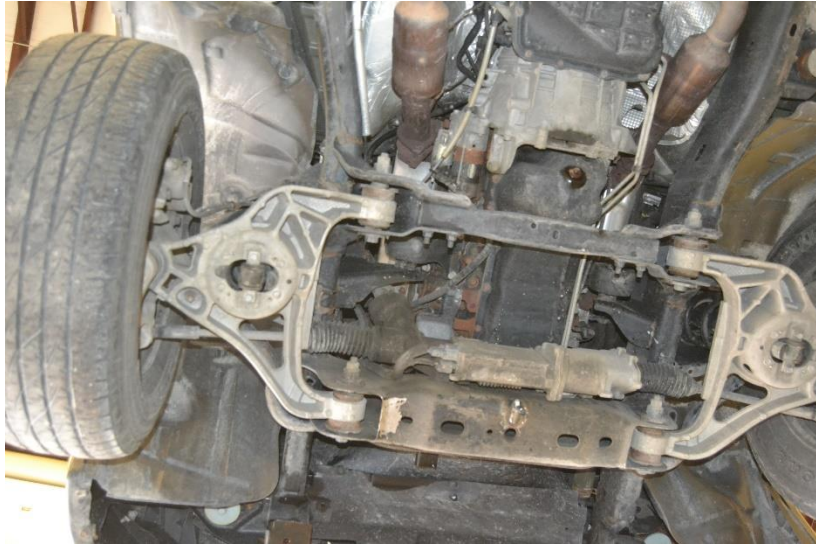

Figure 22. Test Vehicle's Interior Floorboards and Undercarriage, Test No. H34BR-2

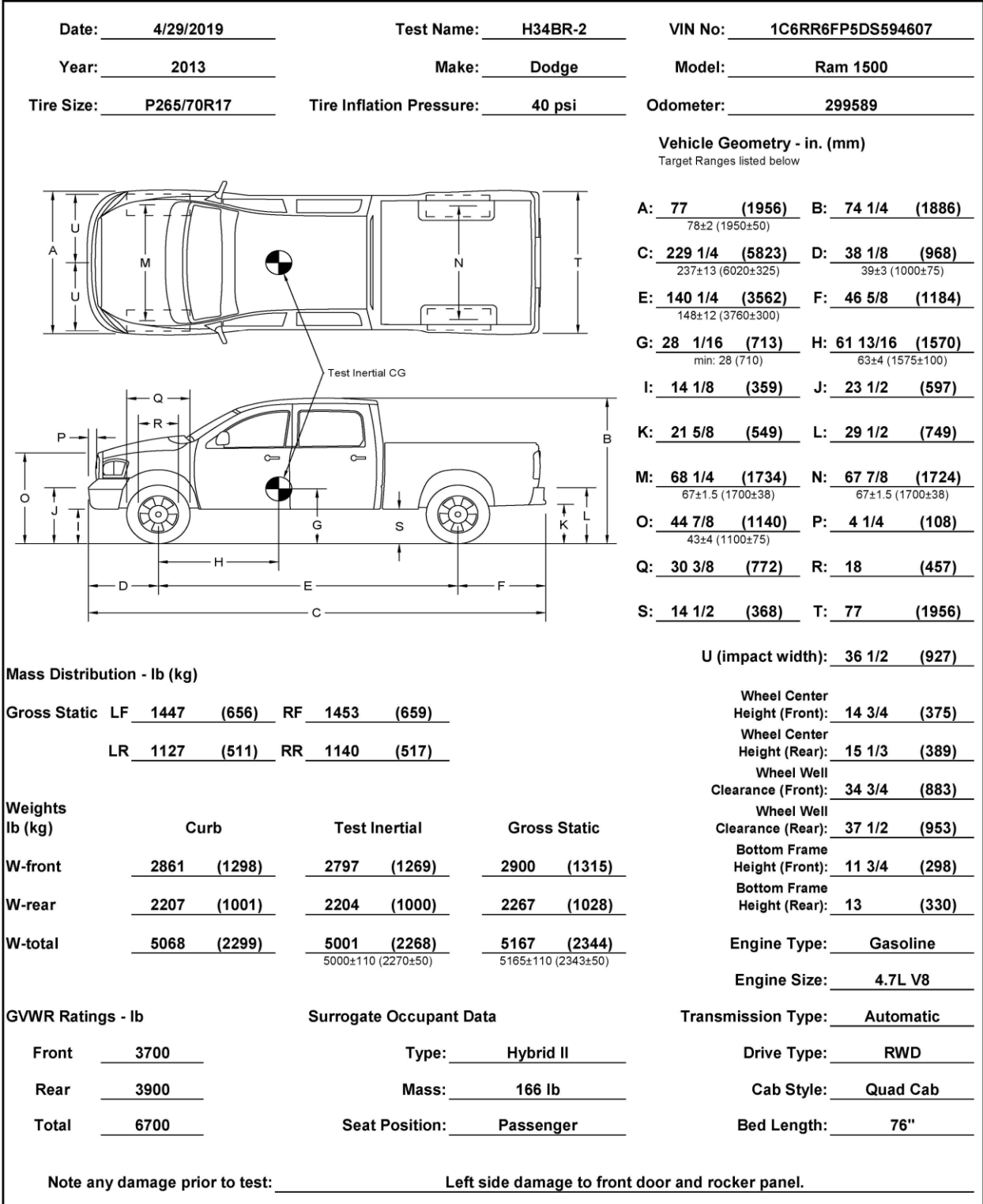

Figure 23. Vehicle Dimensions, Test No. H34BR-2

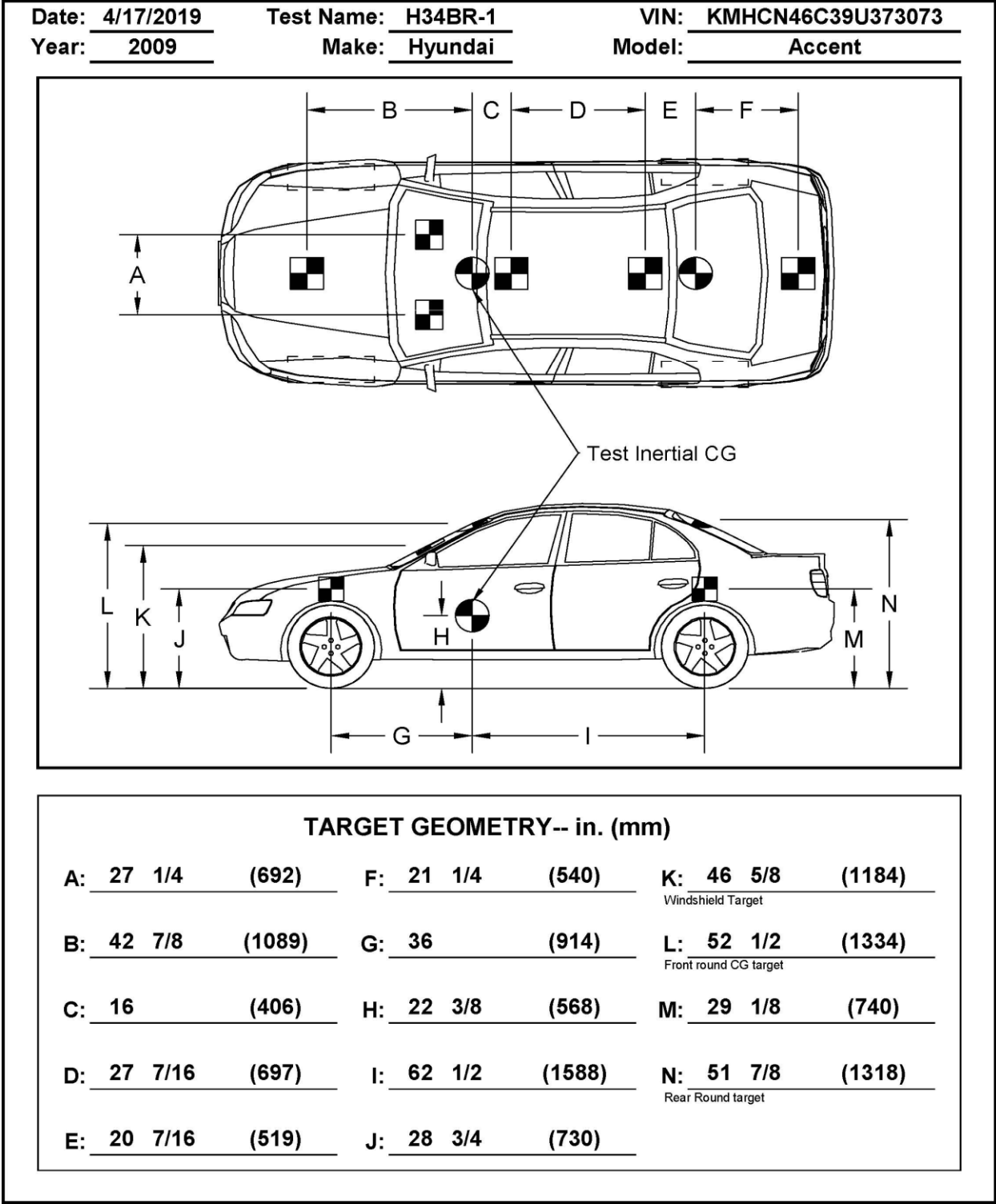

Figure 24. Target Geometry, Test No. H34BR-1

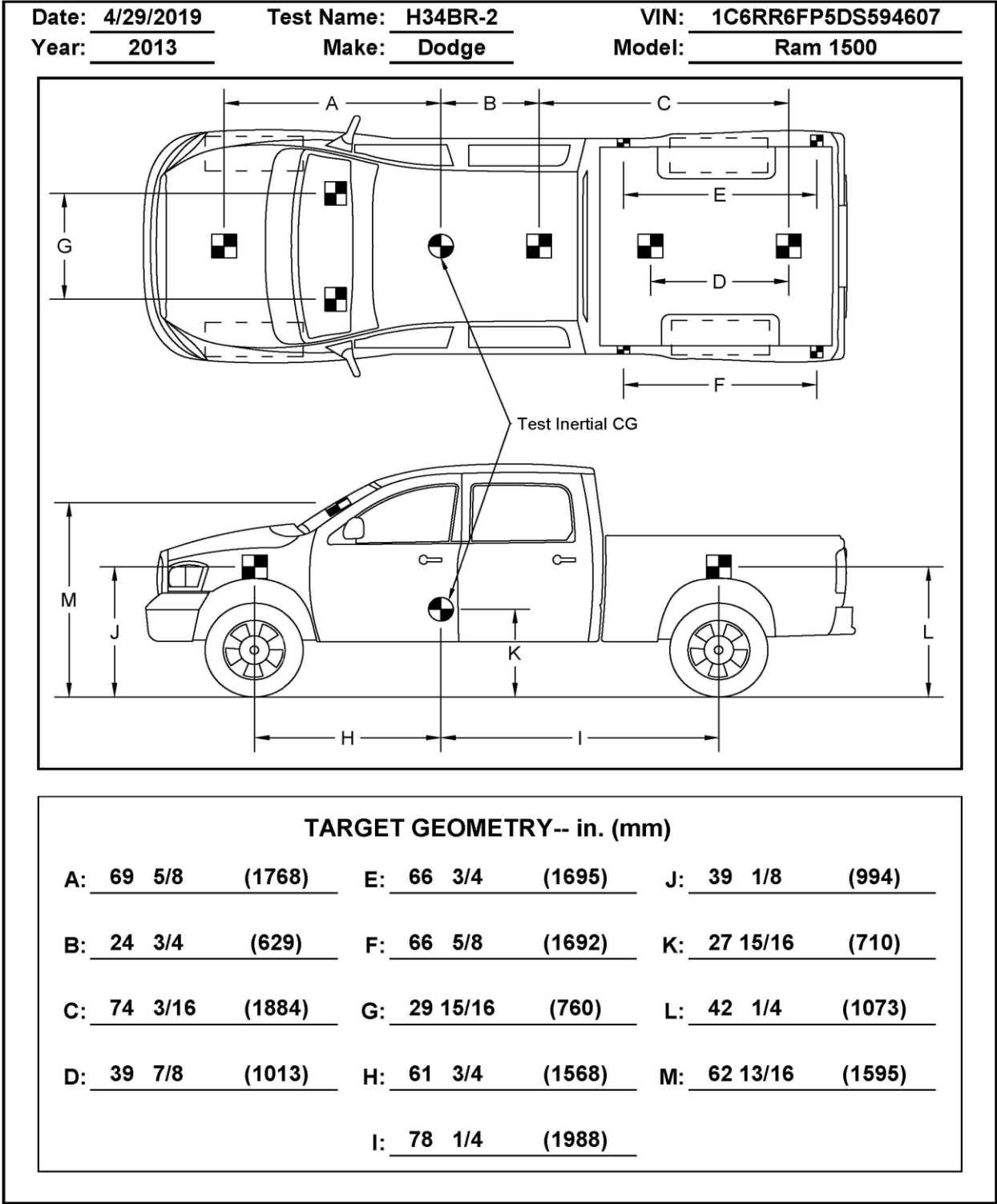

Figure 25. Target Geometry, Test No. H34BR-2

4.4 Simulated Occupant

For test nos. H34BR-1 and H34BR-2, a Hybrid II 50th-Percentile, Adult Male Dummy, equipped with clothing and footwear, was placed in the right-front seat of the test vehicle with the seat belt fastened. The dummy, which had a final weight of 161 lb in test no. H34BR-1 and 166 lb in test no. H34BR-2, was represented by model no. 572 and was manufactured by Android Systems of Carson, California. As recommended by MASH 2016, the dummy was not included in calculating the c.g. location.

4.5 Data Acquisition Systems

4.5.1 Accelerometers

Two environmental shock and vibration sensor/recorder systems were used to measure the accelerations in the longitudinal, lateral, and vertical directions. Both accelerometer systems were mounted near the c.g. of the test vehicles. For test no. H34BR-1, SLICE-2 was used as the primary acceleration system, and DTS was used as the secondary acceleration system. For H34BR-2, SLICE-2 was used as the primary acceleration system, and SLICE-1 was used for the secondary acceleration system. The electronic accelerometer data obtained in dynamic testing was filtered using the SAE Class 60 and the SAE Class 180 Butterworth filter conforming to the SAE J211/1 specifications [10].

The primary accelerometer system for test no. H34BR-1, the SLICE-2 unit, and the two systems for test no. H34BR-2, the SLICE-1 and SLICE-2 units, were modular data acquisition systems manufactured by Diversified Technical Systems, Inc. (DTS) of Seal Beach, California. The acceleration sensors were mounted inside the body of custom-built, SLICE 6DX event data recorder and recorded data at 10,000 Hz to the onboard microprocessor. The SLICE 6DX was configured with 7 GB of non-volatile flash memory, a range of ± 500 g's, a sample rate of 10,000 Hz, and a 1,650 Hz (CFC 1000) anti-aliasing filter. The "SLICEWare" computer software programs and a customized Microsoft Excel worksheet were used to analyze and plot the accelerometer data.

The secondary accelerometer system for test no. H34BR-1, the DTS system, was a two-arm piezoresistive accelerometer system manufactured by Endevco of San Juan Capistrano, California. Three accelerometers were used to measure each of the longitudinal, lateral, and vertical accelerations independently at a sample rate of 10,000 Hz. The accelerometers were configured and controlled using a system developed and manufactured by DTS of Seal Beach, California. More specifically, data was collected using a DTS Sensor Input Module (SIM), Model TDAS3-SIM-16M. The SIM was configured with 16 MB SRAM and 8 sensor input channels with 250 kB SRAM/channel. The SIM was mounted on a TDAS3-R4 module rack. The module rack was configured with isolated power/event/communications, 10BaseT Ethernet and RS232 communication, and an internal backup battery. Both the SIM and module rack were crashworthy. The "DTS TDAS Control" computer software program and a customized Microsoft Excel worksheet were used to analyze and plot the accelerometer data.

4.5.2 Retroreflective Optic Speed Trap

The retroreflective optic speed trap was used to determine the speed of the test vehicles before impact. Five retroreflective targets, spaced at approximately 18-in. intervals, were applied to the right side of the vehicles for test nos. H34BR-1 and H34BR-2. When the emitted beam of light was reflected by the targets and returned to the Emitter/Receiver, a signal was sent to the data acquisition computer, recording at 10,000 Hz, as well as the external LED box activating the LED flashes. The speed was then calculated using the spacing between the retroreflective targets and the time between the signals. LED lights and high-speed digital video analysis are only used as a backup in the event that vehicle speeds cannot be determined from the electronic data.

4.5.3 Rate Transducers

The primary angular rate sensor system mounted inside the body of the SLICE-2 event data recorders was used to measure the rates of rotation of the test vehicle for test nos. H34BR-1 and H34BR-2, and a secondary angular rate sensor system mounted inside the body of the SLICE-1 event data recorder was used to measure the rates of rotation of the test vehicle for test no. H34BR-2. The SLICE MICRO Triax ARS had a range of 1,500 degrees/sec in each of the three directions (roll, pitch, and yaw) and recorded data at 10,000 Hz to the onboard microprocessors. The raw data measurements were then downloaded, converted to the proper Euler angles for analysis, and plotted. The “SLICEWare” computer software program and a customized Microsoft Excel worksheet were used to analyze and plot the angular rate sensor data.

A secondary angular rate sensor, the ARS-1500, with a range of 1,500 degrees/sec in each of the three directions (roll, pitch, and yaw) was used to measure the rates of rotation of the test vehicle for test no. H34BR-1. The angular rate sensor was mounted on an aluminum block inside the test vehicle near the c.g. and recorded data at 10,000 Hz to the DTS SIM. The raw data measurements were then downloaded, converted to the proper Euler angles for analysis, and plotted. The “DTS TDAS Control” computer software program and a customized Microsoft Excel worksheet were used to analyze and plot the angular rate sensor data. Note that the angular rate sensor failed to record the data for test no. H34BR-1 due to equipment malfunction.

4.5.4 Digital Photography

Six AOS high-speed digital video cameras, ten GoPro digital video cameras, one SoloShot camera, and four Panasonic digital video cameras were utilized to film test no. H34BR-1. Six AOS high-speed digital video cameras, nine GoPro digital video cameras, and four Panasonic digital video cameras were utilized to film test no. H34BR-2. Camera details, camera operating speeds, lens information, and a schematic of the camera locations relative to the system are shown in Figures 26 and 27.

The high-speed videos were analyzed using TEMA Motion and Redlake MotionScope software programs. Actual camera speed and camera divergence factors were considered in the analysis of the high-speed videos. A Nikon digital still camera was also used to document pre- and post-test conditions for the test.

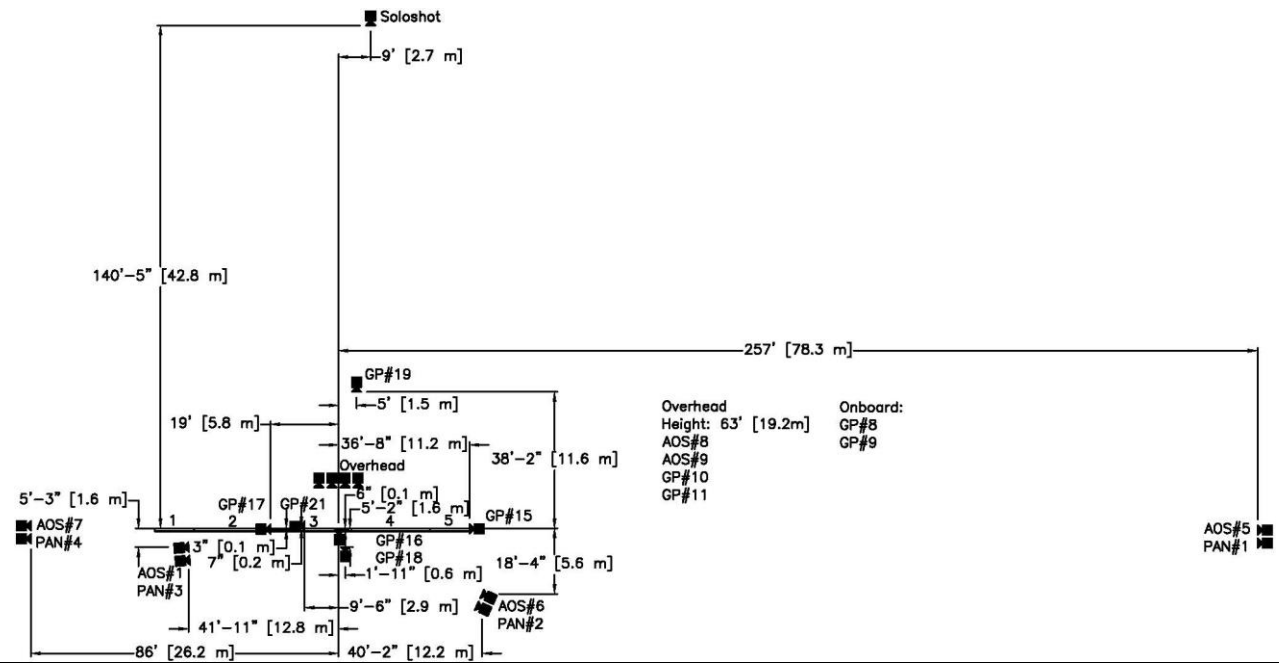

No.	Type	Operating Speed (frames/sec)	Lens	Lens Setting
AOS-1	AOS Vitcam CTM	500	Sigma 28-70	28
AOS-5	AOS X-PRI Gigabit	500	100 mm Fixed	-
AOS-6	AOS X-PRI Gigabit	500	Kowa 25 mm Fixed	-
AOS-7	AOS X-PRI Gigabit	500	Funinon 50 mm Fixed	-
AOS-8	AOS S-VIT 1531	500	Kowa 16 mm Fixed	-
AOS-9	AOS TRI-VIT	500	Kowa 12 mm Fixed	-
GP-8	GoPro Hero 4	120		
GP-9	GoPro Hero 4	120		
GP-10	GoPro Hero 4	120		
GP-11	GoPro Hero 4	240		
GP-15	GoPro Hero 4	240		
GP-16	GoPro Hero 4	120		
GP-17	GoPro Hero 4	240		
GP-18	GoPro Hero 6	240		
GP-19	GoPro Hero 6	240		
GP-21	GoPro Hero 6	240		
PAN-1	Panasonic HC-V770	60		
PAN-2	Panasonic HC-V770	60		
PAN-3	Panasonic HC-V770	60		
PAN-4	Panasonic HC-V770	60		
	SoloShot	120		

Figure 26. Camera Locations, Speeds, and Lens Settings, Test No. H34BR-1

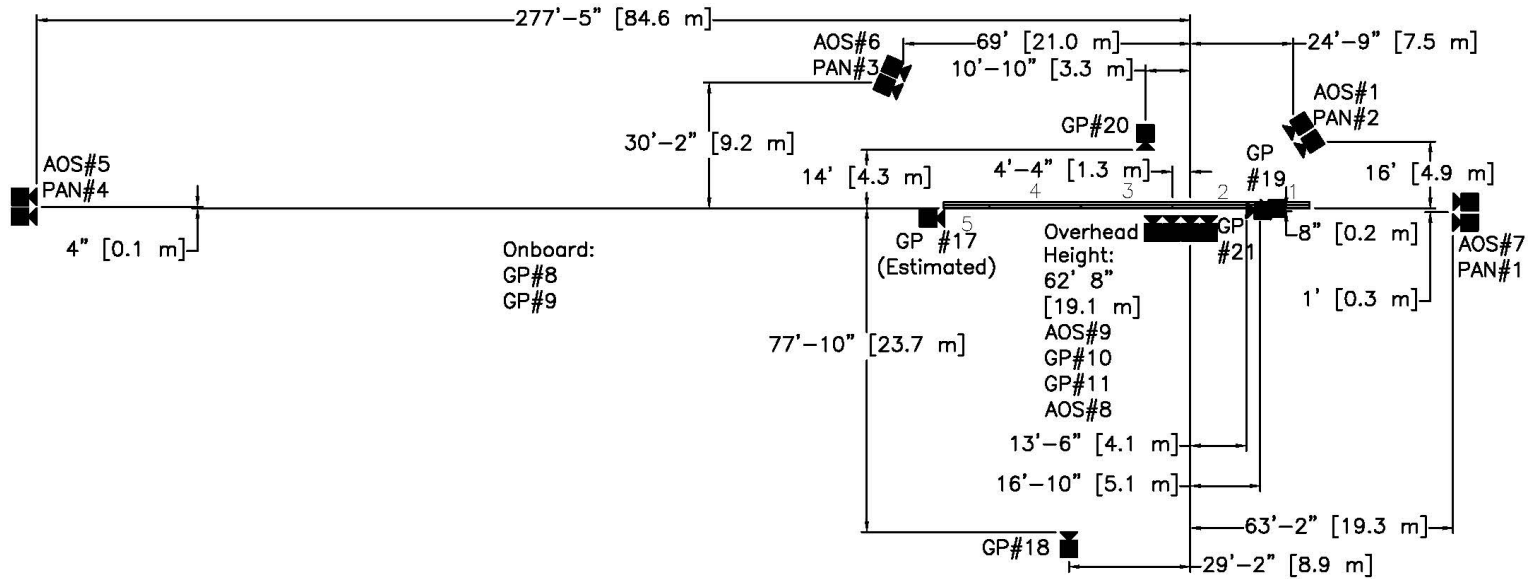

No.	Type	Operating Speed (frames/sec)	Lens	Lens Setting
AOS-1	AOS Vitcam CTM	500	Kowa 25 mm	-
AOS-5	AOS X-PRI Gigabit	500	100 mm Fixed	-
AOS-6	AOS X-PRI Gigabit	500	Kowa 35 mm Fixed	-
AOS-7	AOS X-PRI Gigabit	500	Funinon 50 mm Fixed	-
AOS-8	AOS S-VIT 1531	500	Kowa 16 mm Fixed	-
AOS-9	AOS TRI-VIT	500	Kowa 12 mm Fixed	-
GP-8	GoPro Hero 4	120		
GP-9	GoPro Hero 4	120		
GP-10	GoPro Hero 4	120		
GP-11	GoPro Hero 4	240		
GP-17	GoPro Hero 4	240		
GP-18	GoPro Hero 6	240		
GP-19	GoPro Hero 6	240		
GP-20	GoPro Hero 6	240		
GP-21	GoPro Hero 6	240		
PAN-1	Panasonic HC-V770	120		
PAN-2	Panasonic HC-V770	120		
PAN-3	Panasonic HC-V770	120		
PAN-4	Panasonic HC-V770	120		

Figure 27. Camera Locations, Speeds, and Lens Settings, Test No. H34BR-2

5 FULL-SCALE CRASH TEST NO. H34BR-1

5.1 Weather Conditions

Test no. H34BR-1 was conducted on April 17, 2019 at approximately 2:30 p.m. The weather conditions as per the National Oceanic and Atmospheric Administration (station 14939/LNK) were reported and are shown in Table 3.

Table 3. Weather Conditions, Test No. H34BR-1

Temperature	71° F
Humidity	63%
Wind Speed	14.5 mph
Wind Direction	320° from True North
Sky Conditions	Cloudy
Visibility	10 Statute Miles
Pavement Surface	Dry
Previous 3-Day Precipitation	0.00 in.
Previous 7-Day Precipitation	0.00 in.

5.2 Test Description

Initial vehicle impact was to occur $43\frac{3}{16}$ in. upstream from the expansion joint between barrier segment nos. 3 and 4, as shown in Figure 28, which was selected using the CIP plots found in Table 2.7 of MASH 2016 to increase the probability of vehicle snag and maximize loading of the critical section of the rail expansion joint, which was discussed further in Section 2.1. The 2,430-lb small car impacted the HDOT 34-in. tall, Aesthetic Concrete Bridge Rail at a speed of 62.4 mph and at an angle of 25.7 degrees. The actual point of impact was $\frac{5}{8}$ in. downstream from the targeted point. The vehicle was captured and redirected by the 34-in. tall bridge rail. During the redirection of the vehicle, the right-front fender and right-front wheel experienced snag on the expansion joint and the edge of the aesthetic asperities downstream from impact. The snag was sufficient to push the right-front tire backward and crush the front portion of the right-front fender. However, the snag of the vehicle components did not pose a risk to the vehicle occupant compartment nor did it pose a hazard due to the velocity change or deceleration of the vehicle. The vehicle came to rest 161 ft – 9 in. downstream and 23 ft – 3 in. in front of the system after brakes were applied. Impact Severity (I.S.) is an additional limiting condition required in MASH 2016. The measured I.S. of test no. H34BR-1 was 59.2 kip-ft, which fell into the acceptable range of greater than or equal to 51 kip-ft as defined in MASH 2016 for test designation no. 3-10.

A detailed description of the sequential impact events is contained in Table 4. Sequential photographs are shown in Figures 29 and 30. Documentary photographs of the crash test are shown in Figures 31 through 33. The vehicle trajectory and final position are shown in Figure 34.



Figure 28. Impact Location, Test No. H34BR-1

Table 4. Sequential Description of Impact Events, Test No. H34BR-1

TIME (sec)	EVENT
0.000	Vehicle's front bumper contacted barrier 42 ⁹ / ₁₆ in. upstream from expansion joint between barriers nos. 3 and 4.
0.004	Vehicle's right headlight and right render contacted barrier no. 3.
0.006	Vehicle's right fender deformed, vehicle's right-front tire contacted barrier no. 3.
0.012	Vehicle's right headlight shattered, vehicle's hood contacted barrier no. 3.
0.014	Barrier no. 3 spalled on front-side downstream end.
0.016	Vehicle's hood deformed, vehicle yawed away from system.
0.020	Vehicle pitched downward.
0.024	Vehicle rolled toward system.
0.030	Vehicle's right-front door contacted barrier no. 3.
0.032	Vehicle's windshield cracked, vehicle's right-front door flexed away from frame.
0.034	Vehicle's right-front door deformed.
0.036	Vehicle's front bumper and grille disengaged.
0.040	Vehicle's roof experienced flexure.
0.050	Vehicle's right mirror contacted barrier no. 4.
0.052	Barrier no. 3 cracked on front-side downstream end.
0.064	Vehicle's right-front window shattered.
0.066	Vehicle's left-rear tire became airborne.
0.076	Occupant's head passed through window.
0.080	Vehicle's left-rear tire became airborne.
0.084	Barrier no. 4 spalled on front-side upstream end.
0.088	Barrier no. 4 cracked on front-side upstream end.
0.122	Vehicle rolled away from system.
0.130	Occupant's head re-entered vehicle compartment.
0.138	Vehicle's right-rear door contacted barrier no. 3.
0.142	Vehicle's right-rear door deformed.
0.154	Vehicle's right quarter panel contacted barrier no. 3.
0.158	Vehicle's right quarter panel deformed.
0.160	Vehicle was parallel to system at a speed of 50.9 mph.
0.166	Vehicle's rear bumper contacted barrier no. 4.
0.170	Vehicle's rear bumper deformed.
0.172	Vehicle's right taillight contacted barrier no. 4.
0.176	Vehicle's right taillight shattered.
0.204	Vehicle rolled away from system.
0.216	Vehicle pitched upward.
0.242	Vehicle rolled away from system.
0.290	Vehicle exited system at a speed of 43.0 mph and angle of 6.9 degrees.

0.336	Vehicle's left-rear tire regained contact with ground.
0.406	Vehicle rolled toward system.
0.454	Vehicle yawed toward system.
0.556	Vehicle rolled away from system.
0.922	Vehicle rolled toward system.
1.042	Vehicle rolled away from system.
1.224	Vehicle rolled toward system.
1.420	Vehicle rolled away from system.



0.000 sec



0.100 sec



0.200 sec

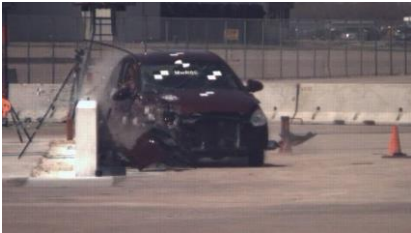

0.300 sec



0.400 sec



0.600 sec



0.000 sec



0.100 sec



0.200 sec



0.300 sec



0.400 sec



0.500 sec

Figure 29. Sequential Photographs, Test No. H34BR-1



0.000 sec



0.050 sec



0.100 sec



0.200 sec



0.300 sec

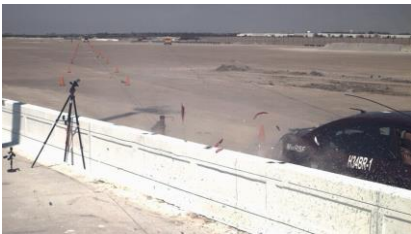

0.400 sec



0.000 sec



0.100 sec



0.200 sec



0.300 sec



0.400 sec



0.500 sec

Figure 30. Additional Sequential Photographs, Test No. H34BR-1



Figure 31. Documentary Photographs, Test No. H34BR-1

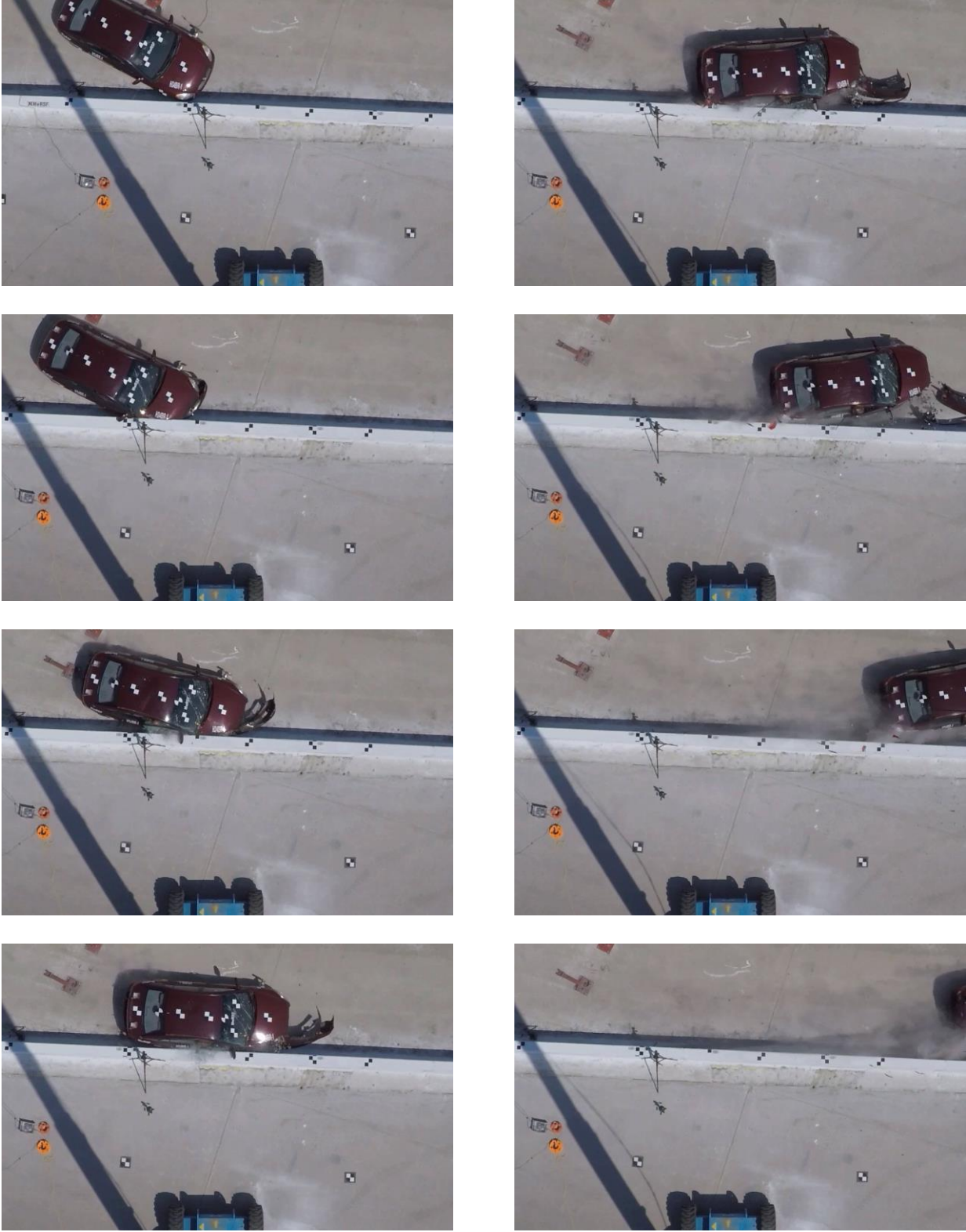

Figure 32. Additional Documentary Photographs, Test No. H34BR-1



Figure 33. Additional Documentary Photographs, Test No. H34BR-1



Figure 34. Vehicle Final Position and Trajectory Marks, Test No. H34BR-1

5.3 Barrier Damage

Damage to the barrier was minor, as shown in Figures 35 through 39. Barrier damage consisted of minor cracking, spalling, and contact marks on the parapet and minor cracking and spalling at the expansion joint between barrier nos. 3 and 4. The locations for all of the listed damage were measured from the expansion joint between barrier nos. 3 and 4 as a reference point. The length of vehicle contact along the barrier was approximately 11 ft – 3 in. which spanned from 4 ft – 9 in. upstream from the expansion joint to 6 ft – 6 in. downstream from the expansion joint.

A 45-in. long and 1½-in. tall spall on the aesthetic asperity was observed 51 in. upstream from the expansion joint. Spalling measuring 4 in. long and 2½ in. wide was found 45 in. upstream from the expansion joint and 14 in. above the ground. Spalling measuring 11 in. long and ½ in. wide was found 34 in. upstream from the expansion joint and 23 in. above the ground. Spalling measuring 5½ in. long and 2½ in. wide was found 33 in. upstream from the expansion joint and 15 in. above the ground. Spalling measuring 61½ in. long was found 32 in. upstream from the expansion joint to 29½ in. downstream of the expansion joint and 32 in. above the ground. Spalling measuring 5 in. long, 10 in. wide, and ½ in. deep was found 3 in. upstream from the expansion joint and 14 in. above the ground. Spalling measuring 6 in. long was found 2 in. upstream from the expansion joint and 24 in. above the ground. A ½-in. diameter by ½-in. deep hole was observed 53 in. upstream from the expansion joint and 17½ in. above the ground. A 1-in. diameter by ½-in. deep hole was observed 24 in. upstream from the expansion joint and 23½ in. above the ground. Grout was disengaged over a 12½ in. height at the expansion joint was observed located 9½ in. above the ground.

Minor cracking of the barrier was also observed in several locations. A 19½-in. diagonal crack that started 18½ in. above the ground and ended 33½ in. above the ground was found 70½ in. upstream from the expansion joint. An 18½-in. diagonal crack that started 11 in. above the ground and ended 18½ in. above the ground was found 60 in. upstream from the expansion joint. A third smaller crack was noted on the top of the barrier starting near the middle of the expansion joint between barrier nos. 3 and 4 and extending diagonally approximately 8 in. downstream and toward the back of the barrier.



Figure 35. System Damage, Test No. H34BR-1



Figure 36. Traffic-Side System Damage, Test No. H34BR-1



Figure 37. Traffic-Side System Damage, Test No. H34BR-1

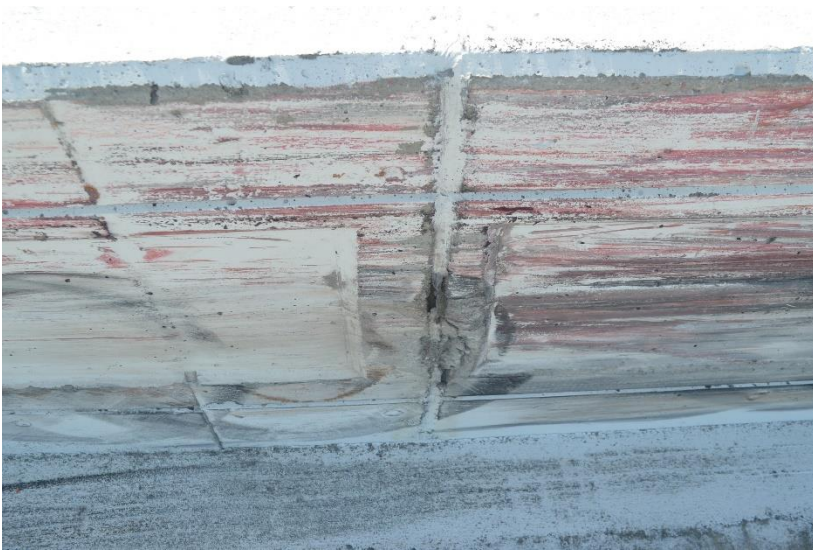

Figure 38. Traffic-Side System Damage, Test No. H34BR-1



Figure 39. Back-Side System Damage, Test No. H34BR-1

The maximum lateral permanent set of the barrier system was 0.2 in., which occurred at the downstream end of barrier no. 2, as measured in the field. The maximum lateral dynamic barrier deflection, including tipping of the barrier along the top surface, was 0.3 in. at the upstream end of barrier no. 3, as determined from high-speed digital video analysis. The working width of the system was found to be 10.3 in., also determined from high-speed digital video analysis. A schematic of the permanent set deflection, dynamic deflection, and working width is shown in Figure 40.

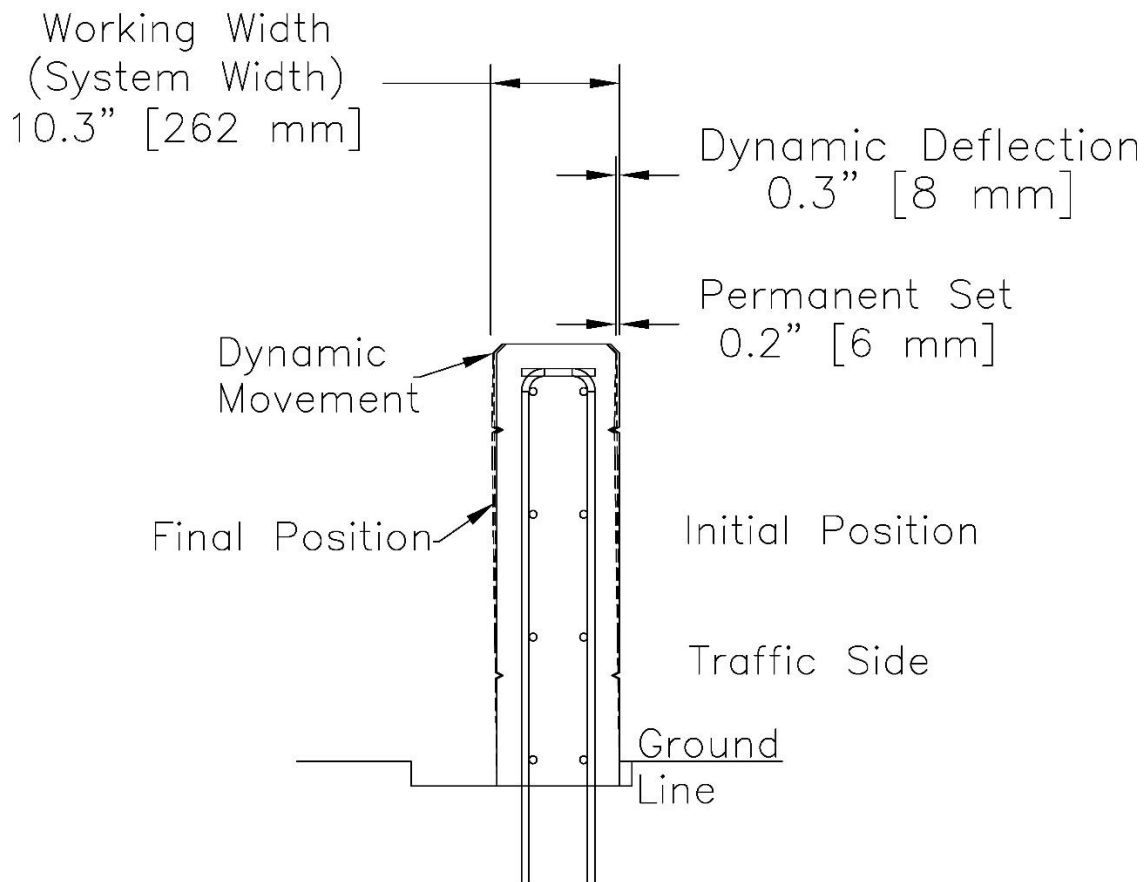

Figure 40. Permanent Set Deflection, Dynamic Deflection, and Working Width, Test No. H34BR-1

5.4 Vehicle Damage

The damage to the vehicle was moderate, as shown in Figures 41 through 45. The maximum occupant compartment intrusions are listed in Table 5 along with the intrusion limits established in MASH 2016 for various areas of the occupant compartment. MASH 2016 defines intrusion or deformation as the occupant compartment being deformed and reduced in size with no observed penetration. Note that none of the established MASH 2016 intrusion limits were violated. The lateral B-Pillar and side door above and below the seat deformed slightly outward, which is not considered crush toward the occupant, is denoted as negative numbers in Table 5, and is not evaluated by MASH 2016 criteria. Complete occupant compartment and vehicle intrusions and the corresponding locations are provided in Appendix C.

The majority of the damage was concentrated on the right-front fender and right-front wheel of the vehicle where the impact had occurred. A small section of the seam where the floor pan and toe pan connected near the left-front corner of the right-side floor pan split due to floor pan deformation. The split seam was not due to intrusion of the barrier or a component of the vehicle. The vehicle's engine hood partially disengaged, but it remained attached to the vehicle's body. The front bumper and bumper cover disengaged from the vehicle. Kinks were found on the bottom support of the radiator, and the right radiator support was bent toward the engine compartment. A 23 $\frac{1}{8}$ -in. dent on the right side of the hood crushed 5 in. inward and toward the engine compartment. The right-front fender was crushed and had contact marks with the most significant occurring near the front of the wheel well. A 38 $\frac{1}{2}$ -in. long x 7 $\frac{1}{8}$ -in. wide x 1 $\frac{1}{2}$ -in. deep dent was found on the right-front door. The right-rear door was dented and scraped just ahead of the rear quarter panel.

It should be noted that the passenger side window fractured, and a large tear was visible in the vehicle windshield. Review of the high-speed video revealed that the side window damage was due to crush of the side of the vehicle door and not due to direct contact with the test article. Similarly, the video data showed that the tearing of the windshield was formed due to crushing of the right front corner of the windshield which propagated a shear crack through the glass and the liner. Neither of these items were in violation of the MASH 2016 criteria as none of the damage occurred due to contact with the test article or debris, nor was there the potential for the barrier to intrude into the occupant compartment.

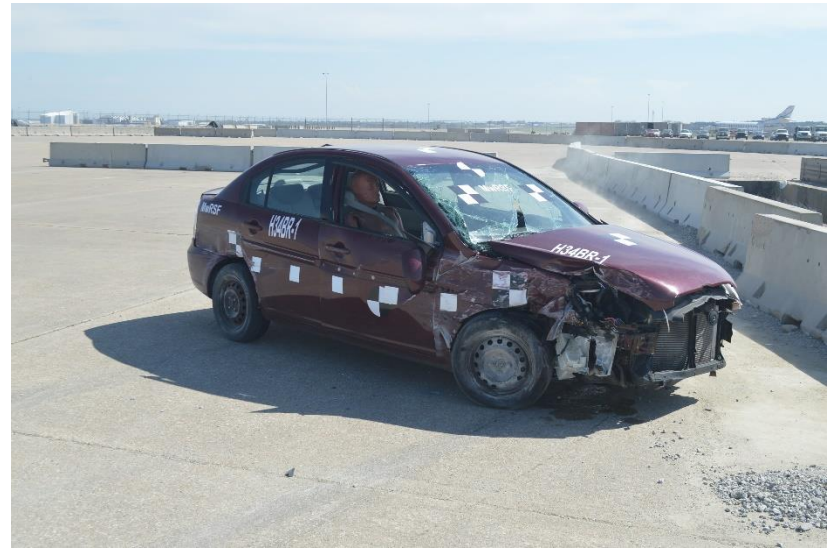

Figure 41. Vehicle Damage, Test No. H34BR-1



Figure 42. Vehicle Damage, Test No. H34BR-1



Figure 43. Vehicle Damage, Test No. H34BR-1



Figure 44. Interior Floorboard Damage, Test No. H34BR-1

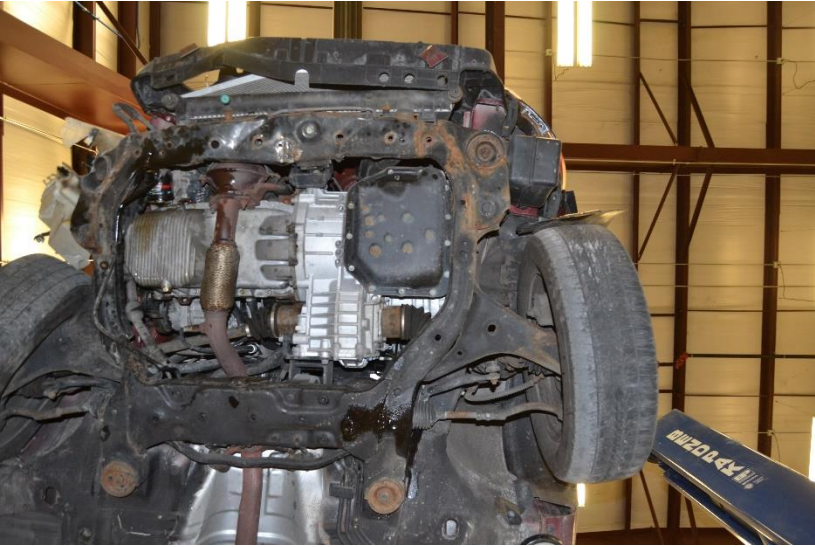

Figure 45. Undercarriage Damage, Test No. H34BR-1

Table 5. Maximum Occupant Compartment Intrusion by Location, Test No. H34BR-1

LOCATION	MAXIMUM INTRUSION in.	MASH 2016 ALLOWABLE INTRUSION in.
Wheel Well & Toe Pan	1.9	≤ 9
Floor Pan & Transmission Tunnel	3.1	≤ 12
A-Pillar	1.1	≤ 5
B-Pillar	0.8	≤ 5
A-Pillar (Lateral)	0.5	≤ 3
B-Pillar (Lateral)	-0.9	N/A ²
Side Front Panel (in Front of A-Pillar)	1.9	≤ 12
Side Door (Above Seat)	-3.4	N/A ²
Side Door (Below Seat)	-1.1	N/A ²
Roof	0.4	≤ 4
Windshield	0.8	≤ 3
Side Window	Shattered due to side door crush	No shattering resulting from contact with structural member of test article
Dash	1.2	N/A ¹

Note: Negative values denote outward deformation

N/A¹ – No MASH 2016 criteria exists for this location

N/A² – MASH 2016 criteria is not applicable when deformation is outward

5.5 Occupant Risk

The calculated occupant impact velocities (OIVs) and maximum 0.010-sec average occupant ridedown accelerations (ORAs) in both the longitudinal and lateral directions, as determined from the accelerometer data, are shown in Table 6. Note that the OIVs and ORAs were within suggested limits, as provided in MASH 2016. The calculated THIV, PHD, and ASI values are also shown in Table 6. The recorded data from the accelerometers and the rate transducers are shown graphically in Appendix D.

Table 6. Summary of OIV, ORA, THIV, PHD, and ASI Values, Test No. H34BR-1

Evaluation Criteria		Transducer		MASH 2016 Limits
		SLICE-2 (primary)	DTS	
OIV ft/s	Longitudinal	-23.41	-25.16	±40
	Lateral	-32.76	-29.78	±40
ORA g's	Longitudinal	-4.11	-3.76	±20.49
	Lateral	-10.63	-12.92	±20.49
MAX. ANGULAR DISPL. deg.	Roll	5.7	N/A	±75
	Pitch	-2.5	N/A	±75
	Yaw	-39.0	N/A	not required
THIV ft/s		39.68	N/A	not required
PHD g's		10.90	N/A	not required
ASI		2.54	2.39	not required

N/A – Data not available due to equipment malfunction

5.6 Barrier Loads

The longitudinal and lateral vehicle accelerations, as measured at the vehicle's c.g., were also processed using a SAE CFC-60 filter and a 50-msec moving average. The 50-msec moving average vehicle accelerations were then combined with the uncoupled yaw angle versus time data in order to estimate the vehicular loading applied to the barrier system. From the data analysis, the perpendicular impact forces were determined for the bridge rail, as shown in Figure 46. The maximum perpendicular (i.e., lateral) load imparted to the barrier was 58.8 kips determined by the SLICE-2 (primary) unit.

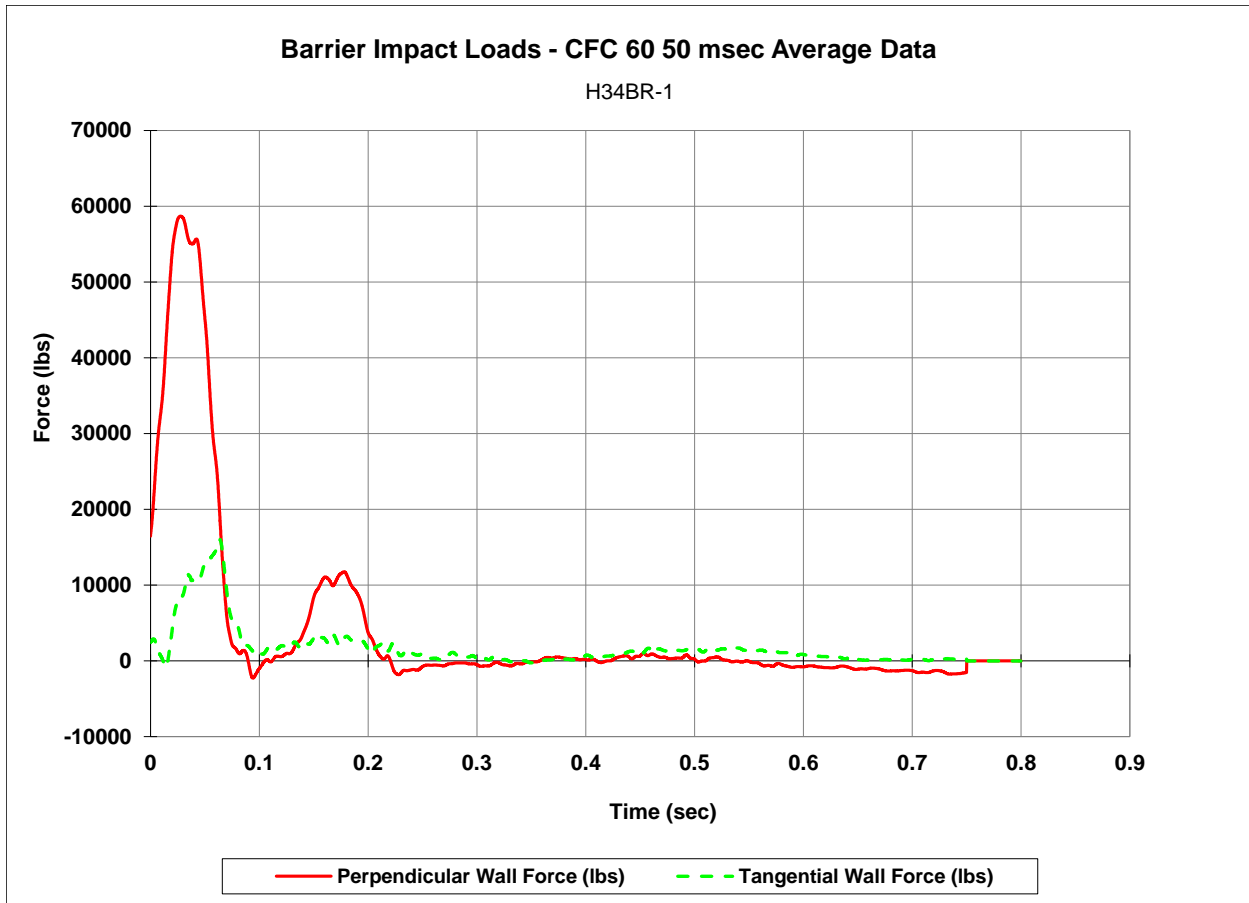
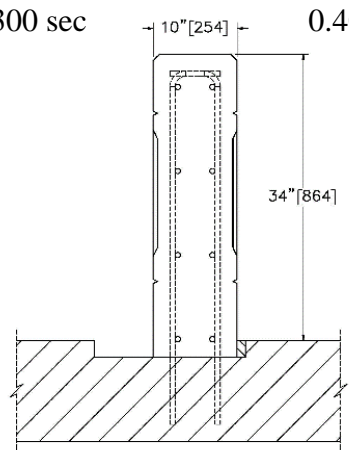
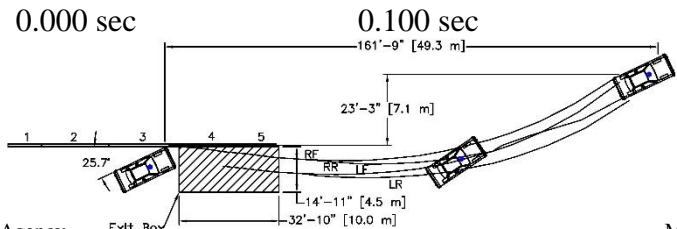

Figure 46. Perpendicular and Tangential Forces Imparted to the Barrier System (SLICE-2), Test No. H34BR-1

5.7 Discussion

The analysis of the test results for test no. H34BR-1 showed that the system adequately contained and redirected the 1100C vehicle with controlled lateral displacements of the barrier. A summary of the test results and sequential photographs are shown in Figure 47. Detached elements, fragments, or other debris from the test article did not penetrate or show potential for penetrating the occupant compartment, or present an undue hazard to other traffic, pedestrians, or work-zone personnel. Deformations of, or intrusions into, the occupant compartment that could have caused serious injury did not occur. The passenger side window shattered due to crush of the side of the vehicle door and not due to direct contact with the test article. The test vehicle did not penetrate nor ride over the barrier and remained upright during and after the collision. Vehicle roll, pitch, and yaw angular displacements, as shown in Appendix D, were deemed acceptable, because they did not adversely influence occupant risk nor cause rollover. After impact, the vehicle exited the barrier at an angle of 6.9 degrees, and its trajectory did not violate the bounds of the exit box. Therefore, test no. H34BR-1 was determined to be acceptable according to the MASH 2016 safety performance criteria for test designation no. 3-10.



- Test Agency MwRSF
- Test Number..... H34BR-1
- Date..... 4/17/2019
- MASH 2016 Test Designation No..... 3-10
- Test Article..... HDOT 34-in. Tall, Aesthetic Concrete Bridge Rail
- Total Length 88 ft
- Key Component – Barrier Segment
 - Length 22 ft
 - Depth 10 in.
 - Height..... 34 in.
- Key Component – Barrier Segment
 - Length 11 ft
 - Depth 10 in.
 - Height..... 34 in.
- Type of Support Surface..... Concrete Tarmac
- Anchor..... Vertical rebar anchored to concrete tarmac and epoxied
- Vehicle Make /Model..... 2009 Hyundai Accent
- Curb..... 2,511 lb
- Test Inertial..... 2,430 lb
- Gross Static..... 2,589 lb
- Impact Conditions
 - Speed 62.4 mph
 - Angle 25.7 deg.
 - Impact Location..... 42⁹/₁₆ in. upstream from the expansion joint, barrier nos. 3 and 4
- Impact Severity 59.2 kip-ft > 51 kip-ft limit from MASH 2016
- Exit Conditions
 - Speed 43.0 mph
 - Angle 6.9 deg.
- Exit Box Criterion..... Pass
- Vehicle Stability..... Satisfactory
- Vehicle Stopping Distance 161 ft – 9 in. downstream, 23 ft - 3 in. laterally behind
- Vehicle Damage..... Moderate
 - VDS [11] 1-RFQ-4
 - CDC [12]..... 01-RRER-5
 - Maximum Interior Deformation 3.1 in.

- Test Article Damage Minimal
- Maximum Test Article Deflections
 - Permanent Set 0.2 in.
 - Dynamic 0.3 in.
 - Working Width..... 10.3 in.
- Transducer Data

Evaluation Criteria		Transducer		MASH 2016 Limit
		SLICE-2 (primary)	DTS	
OIV ft/s (m/s)	Longitudinal	-23.41	-25.16	±40
	Lateral	-32.76	-29.78	±40
ORA g's	Longitudinal	-4.11	-3.76	±20.49
	Lateral	-10.63	-12.92	±20.49
MAX ANGULAR DISP. deg.	Roll	5.7	N/A	±75
	Pitch	-2.5	N/A	±75
	Yaw	-39.0	N/A	not required
THIV – ft/s		39.68	N/A	not required
PHD – g's		10.90	N/A	not required
ASI		2.54	2.39	not required

N/A – Data not available due to equipment malfunction

Figure 47. Summary of Test Results and Sequential Photographs, Test No. H34BR-1

6 FULL-SCALE CRASH TEST NO. H34BR-2

6.1 Weather Conditions

Test no. H34BR-2 was conducted on April 29th, 2019 at approximately 2:15 p.m. The weather conditions as per the National Oceanic and Atmospheric Administration (station 14939/LNK) were reported and are shown in Table 7.

Table 7. Weather Conditions, Test No. H34BR-2

Temperature	67° F
Humidity	59%
Wind Speed	14.8 mph
Wind Direction	340° from True North
Sky Conditions	Cloudy
Visibility	10 Statute Miles
Pavement Surface	Dry
Previous 3-Day Precipitation	0.21 in.
Previous 7-Day Precipitation	0.42 in.

6.2 Test Description

Initial vehicle impact was to occur 51⁵/₈ in. upstream from the expansion joint between barrier segment nos. 2 and 3, as shown in Figure 48, which was selected using the CIP plots found in Table 2.7 of MASH 2016 to increase the probability of vehicle snag and maximize loading of the critical section of the rail expansion joint. The 5,001-lb pickup truck impacted the HDOT 34-in. tall, Aesthetic Concrete Bridge Rail at a speed of 64.0 mph and at an angle of 25.4 degrees. The actual point of impact was ⁵/₁₆ in. upstream from the targeted impact location. The vehicle was captured and redirected by the 34-in. tall bridge rail. During the redirection of the vehicle, the right-front fender and right-front wheel experienced snag on the expansion joint and the edge of the aesthetic asperities downstream from impact. The snag was sufficient to push the right-front tire backwards and crush the front portion of the right-front fender. In addition, the fender and wheel snag generated some deformation and crush of the right-front portion of the floor pan and the lower portion of the left-front door. However, the snag of the vehicle components did not pose a risk to the vehicle occupant compartment nor did it pose a hazard due to velocity change or vehicle deceleration. The vehicle came to rest 191 ft – 10 in. downstream from the impact point and 4 ft – 10 in. in front of the barrier after brakes were applied. The measured I.S. of test no. H34BR-2 was 126 kip-ft, which fell into the acceptable range of greater than or equal to 106 kip-ft as defined in MASH 2016 for test designation no. 3-11.

A detailed description of the sequential impact events is contained in Table 8. Sequential photographs are shown in Figures 49 and 50. Documentary photographs of the crash test are shown in Figures 51 through 53. The vehicle trajectory and final position are shown in Figure 54.



Figure 48. Impact Location, Test No. H34BR-2

Table 8. Sequential Description of Impact Events, Test No. H34BR-2

TIME (sec)	EVENT
0.000	Vehicle's right-front bumper contacted 51 ¹⁵ / ₁₆ in. upstream from the downstream edge of barrier no. 2.
0.004	Vehicle's right-front bumper deformed.
0.008	Vehicle's right headlight shattered, vehicle's right fender and right-front tire contacted barrier no. 2.
0.010	Vehicle's right fender deformed.
0.014	Vehicle's right headlight contacted barrier no. 2.
0.028	Barrier no. 2 spalled on front side downstream end, vehicle yawed clockwise away from system.
0.032	Vehicle's grille contacted barrier no. 2.
0.036	Vehicle's right-front door contacted barrier no. 2.
0.044	Vehicle's right-front door deformed.
0.052	Vehicle rolled toward system.
0.054	Vehicle's right-front door flexed away from frame at roof.
0.078	Barrier no. 2 cracked on back side downstream end.
0.086	Vehicle's right-front window shattered.
0.094	Vehicle's windshield cracked, vehicle's left-front tire became airborne.
0.110	Passenger surrogate's head passed through right-front door plane.
0.114	Vehicle's grille disengaged.
0.130	Vehicle's left-rear tire became airborne.
0.142	Vehicle's left headlight disengaged.
0.150	Vehicle's right-rear door contacted barrier no. 2.
0.158	Vehicle's right-rear door deformed.
0.176	Vehicle's right quarter panel contacted barrier no. 2.
0.180	Vehicle's right quarter panel deformed.
0.190	Vehicle's right-rear bumper contacted barrier no. 2.
0.192	Vehicle's right-rear bumper deformed, vehicle's right taillight contacted barrier no. 2, and vehicle was parallel to system at a speed of 50.9 mph.
0.198	Vehicle's right taillight shattered.
0.214	Vehicle pitched downward.
0.294	Vehicle's right-rear tire became airborne.
0.404	Vehicle rolled away from system.
0.408	Vehicle exited system at a speed of 44.0 mph and an angle of 8.9 degrees.
0.514	Vehicle pitched upward.
0.614	Vehicle's left-front tire regained contact with ground.
0.660	Vehicle's left-rear tire regained contact with ground.
0.700	Vehicle's right-rear tire regained contact with ground.
0.832	Vehicle rolled toward system.
0.944	Vehicle yawed counterclockwise away from system.
1.068	Vehicle rolled counterclockwise away from system.
3.700	Vehicle came to rest.



0.000 sec



0.100 sec



0.200 sec



0.300 sec



0.400 sec



0.500 sec



0.000 sec



0.100 sec



0.200 sec

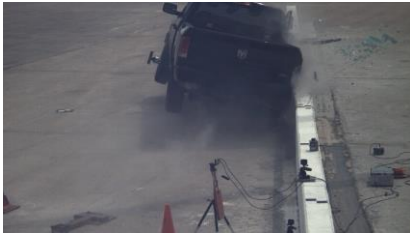

0.300 sec

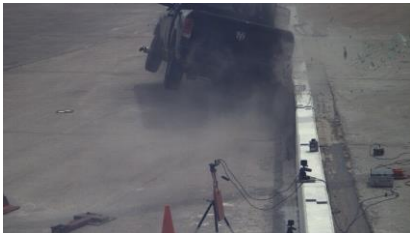

0.400 sec

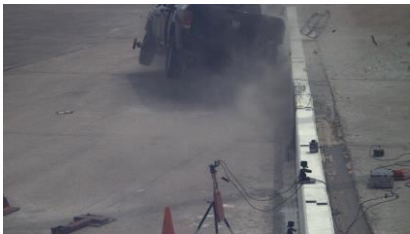

0.500 sec

Figure 49. Sequential Photographs, Test No. H34BR-2



0.000 sec



0.100 sec



0.200 sec



0.300 sec



0.400 sec



0.500 sec



0.000 sec



0.100 sec



0.200 sec



0.300 sec



0.400 sec



0.500 sec

Figure 50. Additional Sequential Photographs, Test No. H34BR-2



Figure 51. Documentary Photographs, Test No. H34BR-2

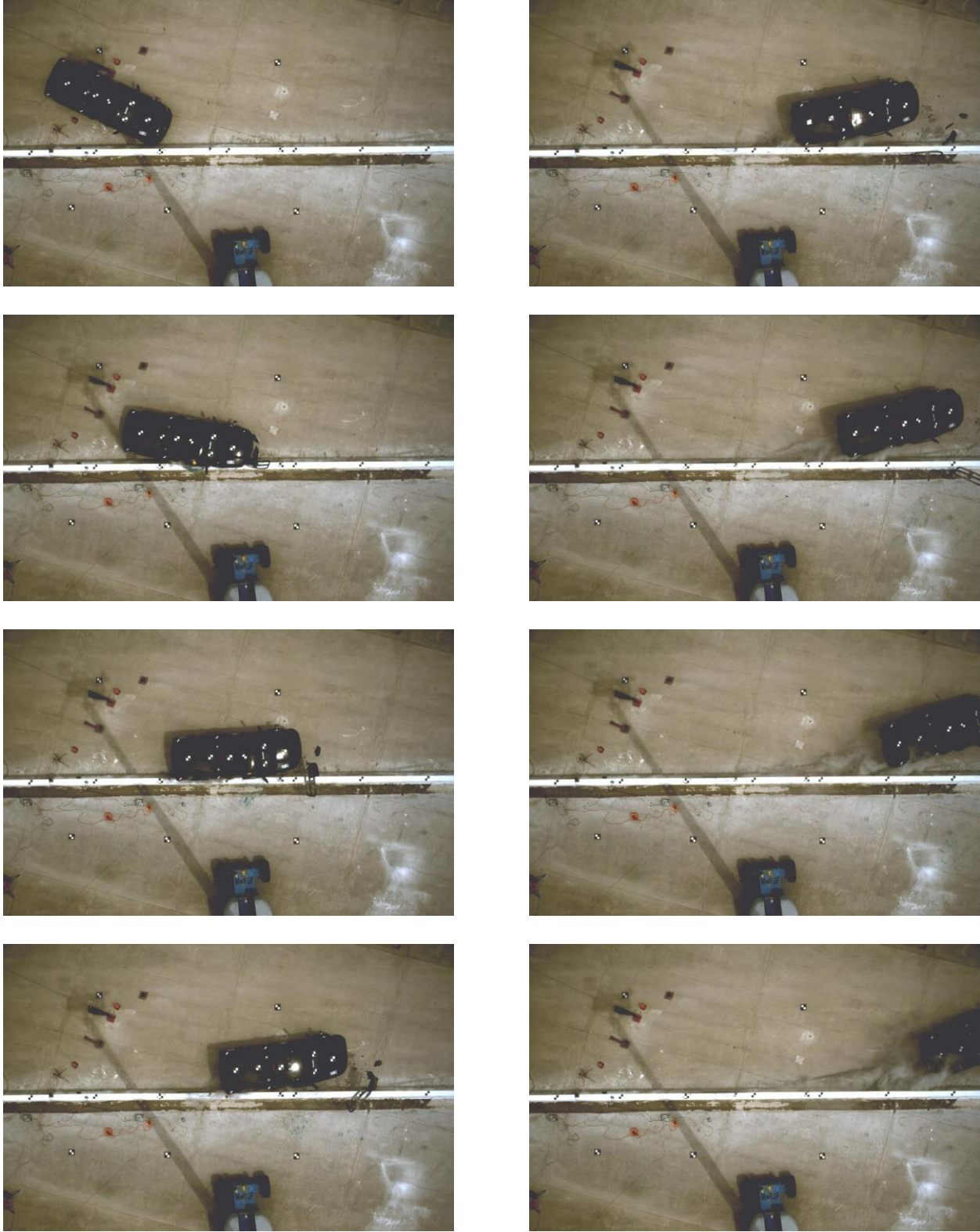

Figure 52. Additional Documentary Photographs, Test No. H34BR-2



Figure 53. Additional Documentary Photographs, Test No. H34BR-2



Figure 54. Vehicle Final Position & Trajectory Marks, Test No. H34BR-2

6.3 Barrier Damage

Damage to the barrier was minimal, as shown in Figures 55 through 58. Barrier damage consisted of contact marks on the front face of the concrete segments, spalling of the concrete, and concrete cracking. The length of vehicle contact along the barrier was approximately 12 ft – 9 in. which spanned from 5 ft – 6¼ in. upstream from the center of the joint between barrier nos. 2 and 3 to 7 ft – 3 in. downstream from the center of the joint between barrier nos. 2 and 3. The locations for all of the listed damage were measured using the expansion joint between barrier nos. 2 and 3 as a reference point.

Tire marks and scuff marks were visible on the front face of barrier nos. 2 and 3. Concrete spalling and cracking occurred at the downstream end of barrier no. 2 and upstream end of barrier no. 3. A 17½-in. x 5-in. x 1-in. piece of concrete was removed 2 in. upstream from the center of the expansion joint between barrier nos. 2 and 3. A 6½-in. long x 2½-in. wide concrete piece that was located 16½ in. from the ground was removed 54 in. upstream from the expansion joint. A 12-in. long x 9½-in. wide piece of concrete, which was located 19½ in. from the ground, was removed 46½ in. upstream from the expansion joint. An 8-in. long x 3¾-in. wide concrete piece that was located 8¾ in. from the ground was removed 4½ in. upstream from the expansion joint.

A 2¼-in. long crack that began on the top face of the barrier was found 56½ in. upstream from the expansion joint. A longer crack was found 42 in. upstream from the expansion joint starting 6½ in. from the ground on the back side of the barrier and extending across the top face to 7 in. A crack was found 68¼ in. upstream from the expansion joint that started 29¾ in. above the ground and extended diagonally upstream and ended 18½ in. above the ground. The most significant crack formed on the back-side surface, which started at the bottom of the barrier and extended on top of the barrier. It started from the bottom and 3 in. upstream of the expansion joint, extending 6¼ in. upstream of the expansion joint and 11¼ in. above the ground, and ended at the top of the barrier and 1 in. upstream of the expansion joint.



Figure 55. System Damage, Test No. H34BR-2



Figure 56. Traffic-Side System Damage, Test No. H34BR-2



Figure 57. Traffic-Side System Damage, Test No. H34BR-2



Figure 58. Back-Side System Damage, Test No. H34BR-2

The maximum lateral permanent set of the barrier system was 0.1 in., including barrier and deck panel shift, which occurred at the downstream end of barrier no. 2, as measured in the field. The maximum lateral dynamic barrier deflection, including tipping of the barrier along the top surface, was 0.2 in. at the upstream end of barrier no. 3, as determined from high-speed digital video analysis. The working width of the system was found to be 17.2 in. also determined from high-speed digital video analysis. A schematic of the permanent set deflection, dynamic deflection, and working width is shown in Figure 59.

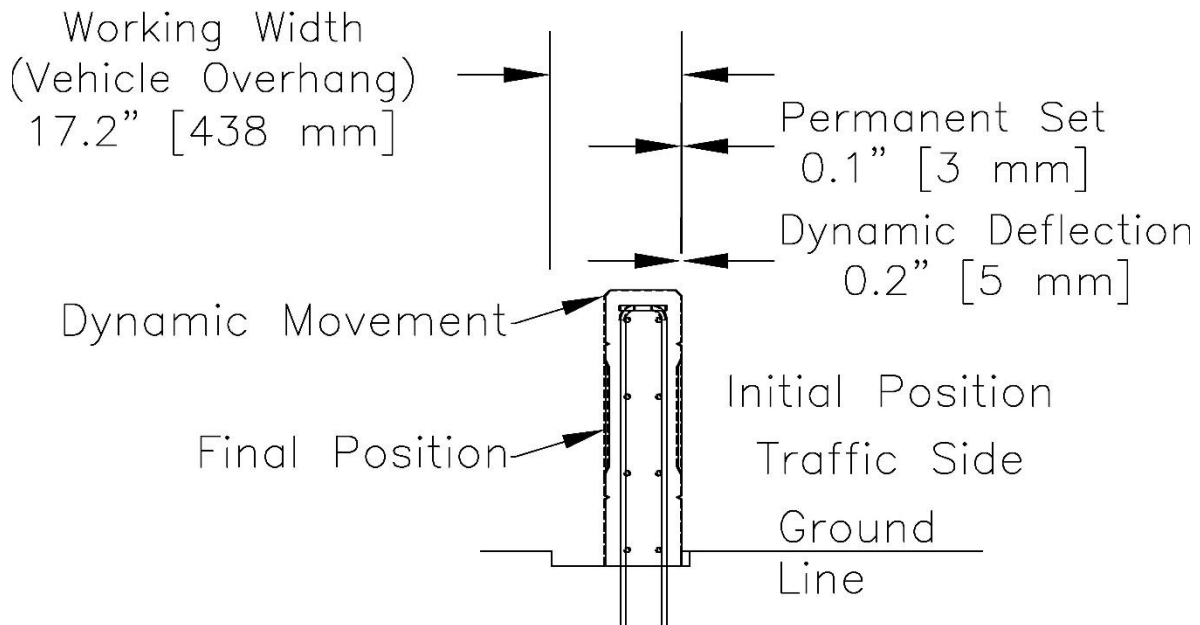

Figure 59. Permanent Set Deflection, Dynamic Deflection, and Working Width, Test No. H34BR-2

6.4 Vehicle Damage

The damage to the vehicle was moderate, as shown in Figures 60 through 64. The maximum occupant compartment intrusions are listed in Table 9 along with the intrusion limits established in MASH 2016 for various areas of the occupant compartment. MASH 2016 defines intrusion or deformation as the occupant compartment being deformed and reduced in size with no observed penetration. Note that none of the established MASH 2016 intrusion limits were violated. The lateral A- and B-pillars and the side door above the seat deformed slightly outward, which is not considered crush toward the occupant, is denoted as negative numbers in Table 9, and is not evaluated by MASH 2016 criteria. Complete occupant compartment and vehicle intrusions and the corresponding locations are provided in Appendix C.

The majority of the damage was concentrated on the right-front corner and right side of the vehicle where the impact had occurred. The right side of the bumper was crushed inward and backward. The right-front fender was crushed inward toward the centerline of the vehicle and engine compartment. The right-front steel rim was deformed and crushed, and the right-front tire was torn and deformed. The right upper control arm was fractured. The grille was disengaged away

from the vehicle. The left-side headlight was disengaged away from the vehicle and right-side headlight and fog light were shattered. The right side of the radiator was pushed backward. A 16 $\frac{1}{2}$ -in. long x 21-in. wide x 2 $\frac{1}{2}$ -in. deep dent and scraping were observed on the entire right side. The right-front door was ajar, and creases were found in the door's sheet metal. The right-rear steel rim was crushed, and the tire was torn. The right side of the rear bumper was dented and scuffed. It should be noted that the window on the right-front side was shattered. It should be noted that the passenger side window was fractured. Review of the high-speed video revealed that the side window damage was due to crush of the side of the vehicle door and not due to direct contact with the test article. Thus, the side window damage was not in violation of the MASH criteria as it did not occur due to contact with the test article or debris. The bottom-right side of the windshield had a hairline crack, and no cracks were found on the left side of the windshield. The left-front fender was dented at the top and back. Minor scrapes and dents were found at the left-front and left-rear doors. The roof and remaining window glass remained undamaged.



Figure 60. Vehicle Damage, Test No. H34BR-2



Figure 61. Vehicle Damage, Test No. H34BR-2



Figure 62. Vehicle Damage, Test No. H34BR-2

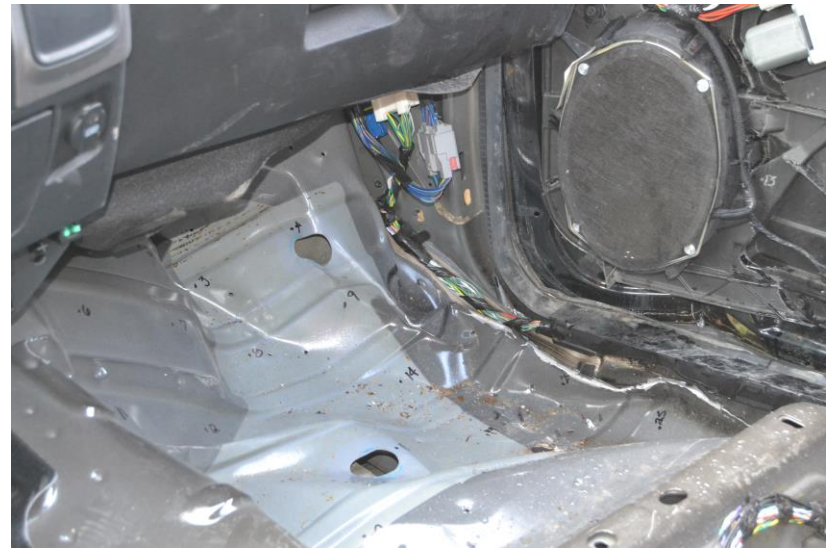

Figure 63. Interior Floorboard Damage, Test No. H34BR-2



Figure 64. Undercarriage Damage, Test No. H34BR-2

Table 9. Maximum Occupant Compartment Intrusion by Location, Test No. H34BR-2

LOCATION	MAXIMUM INTRUSION in.	MASH 2016 ALLOWABLE INTRUSION in.
Wheel Well & Toe Pan	4.8	≤ 9
Floor Pan & Transmission Tunnel	0.8	≤ 12
A-Pillar	0.4	≤ 5
B-Pillar	0.4	≤ 5
A-Pillar (Lateral)	-1.1	N/A ²
B-Pillar (Lateral)	-0.8	N/A ²
Side Front Panel (in Front of A-Pillar)	5.4	≤ 12
Side Door (Above Seat)	-2.5	N/A ²
Side Door (Below Seat)	1.4	≤ 12
Roof	0.2	≤ 4
Windshield	0.0	≤ 3
Side Window	Shattered due to side door crush	No shattering resulting from contact with structural member of test article
Dash	0.7	N/A ¹

Note: Negative values denote outward deformation

N/A¹ – No MASH 2016 criteria exists for this location

N/A² – MASH 2016 criteria is not applicable when deformation is outward

6.5 Occupant Risk

The calculated occupant impact velocities (OIVs) and maximum 0.010-sec average occupant ridedown accelerations (ORAs) in both the longitudinal and lateral directions, as determined from the accelerometer data, are shown in Table 10. Note that the OIVs and ORAs were within suggested limits, as provided in MASH 2016. The calculated THIV, PHD, and ASI values are also shown in Table 10. The recorded data from the accelerometers and the rate transducers are shown graphically in Appendix E.

Table 10. Summary of OIV, ORA, THIV, PHD, and ASI Values, Test No. H34BR-2

Evaluation Criteria		Transducer		MASH 2016 Limits
		SLICE-1	SLICE-2 (primary)	
OIV ft/s	Longitudinal	-21.94	-21.83	±40
	Lateral	-24.65	-27.53	±40
ORA g's	Longitudinal	-4.00	-4.06	±20.49
	Lateral	-9.83	-7.17	±20.49
MAX. ANGULAR DISPL. deg.	Roll	17.0	13.7	±75
	Pitch	2.4	-2.8	±75
	Yaw	-44.6	-44.9	not required
THIV ft/s		31.26	34.80	not required
PHD g's		10.29	7.76	not required
ASI		1.71	1.88	not required

6.6 Barrier Loads

The longitudinal and lateral vehicle accelerations, as measured at the vehicle's c.g., were also processed using a SAE CFC-60 filter and a 50-msec moving average. The 50-msec moving average vehicle accelerations were then combined with the uncoupled yaw angle versus time data in order to estimate the vehicular loading applied to the barrier system. From the data analysis, the perpendicular impact forces were determined for the bridge rail, as shown in Figure 65. The maximum perpendicular (i.e., lateral) load imparted to the barrier was 88.6 kips determined by the SLICE-2 (primary) unit.

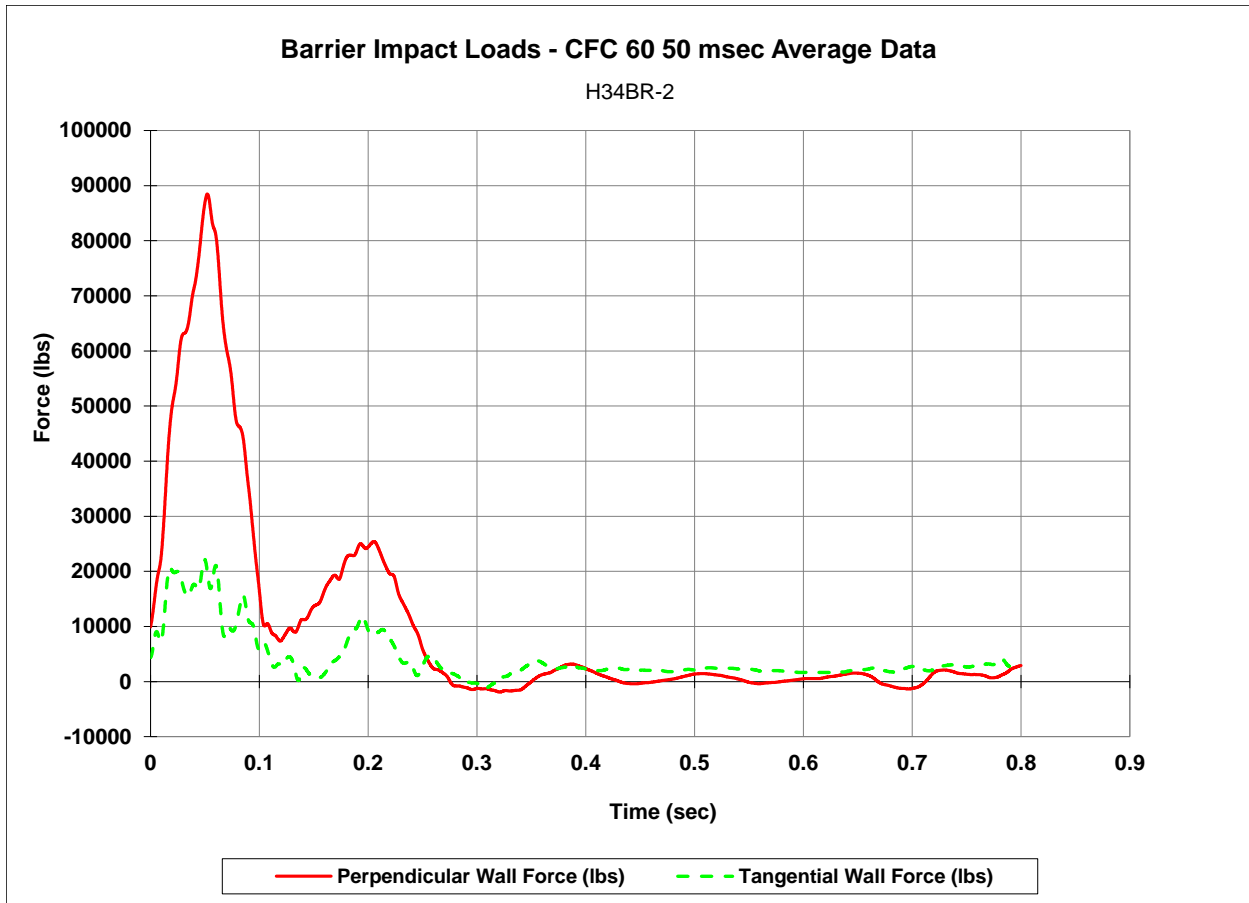
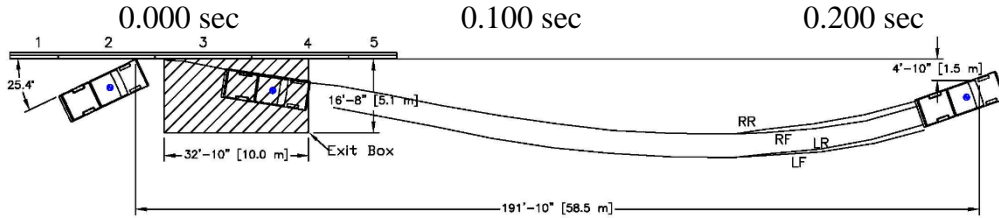
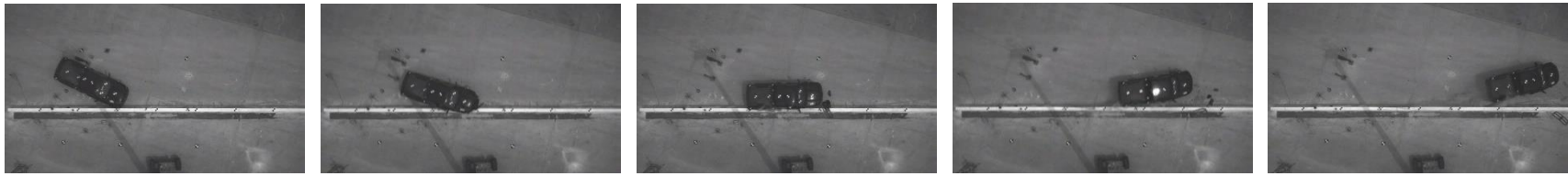

Figure 65. Perpendicular and Tangential Forces Imparted to the Barrier System (SLICE-2), Test No. H34BR-2

6.7 Discussion

The analysis of the test results for test no. H34BR-2 showed that the system adequately contained and redirected the 2270P vehicle with controlled lateral displacements of the barrier. A summary of the test results and sequential photographs are shown in Figure 66. Detached elements, fragments, or other debris from the test article did not penetrate or show potential for penetrating the occupant compartment, or present an undue hazard to other traffic, pedestrians, or work-zone personnel. Deformations of, or intrusions into, the occupant compartment that could have caused serious injury did not occur. The test vehicle did not penetrate nor ride over the barrier and remained upright during and after the collision. Vehicle roll, pitch, and yaw angular displacements, as shown in Appendix E, were deemed acceptable, because they did not adversely influence occupant risk nor cause rollover. After impact, the vehicle exited the barrier at an angle of 8.9 degrees, and its trajectory did not violate the bounds of the exit box. Therefore, test no. H34BR-2 was determined to be acceptable according to the MASH 2016 safety performance criteria for test designation no. 3-11.



0.300 sec 0.400 sec

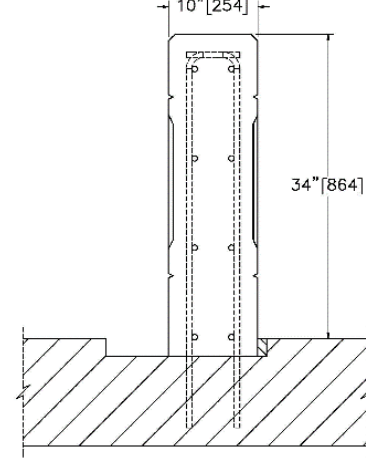

- Test Agency MwRSF
- Test Number..... H34BR-2
- Date..... 4/29/2019
- MASH 2016 Test Designation No..... 3-11
- Test Article..... HDOT 34-in. Tall Aesthetic Concrete Bridge Rail
- Total Length 88 ft
- Key Component – Barrier Segment
 - Length 22 ft
 - Width..... 10 in.
 - Depth 34 in.
- Key Component – Barrier Segment
 - Length 11 ft
 - Width..... 10 in.
 - Depth 34 in.
- Type of Support Surface..... Concrete Tarmac
 - Anchor..... Vertical rebar anchored to concrete tarmac and epoxied
- Vehicle Make /Model..... 2013 Dodge Ram 1500 quad cab pickup truck
 - Curb..... 5,068 lb
 - Test Inertial..... 5,001 lb
 - Gross Static..... 5,167 lb
- Impact Conditions
 - Speed 64.0 mph
 - Angle 25.4 deg.
 - Impact Location..... 51¹⁵/₁₆ in. upstream from the expansion joint, barrier nos. 2 and 3
- Impact Severity 126.4 kip-ft > 106 kip-ft limit from MASH 2016
- Exit Conditions
 - Speed 44.0 mph
 - Angle 8.9 deg.
- Exit Box Criterion Pass
- Vehicle Stability..... Satisfactory
- Vehicle Stopping Distance 191 ft – 10 in. downstream, 4 ft – 10 in. laterally in front
- Vehicle Damage..... Moderate
 - VDS [11] 1-RFQ-4
 - CDC [12] 01-RRER-5
 - Maximum Interior Deformation 5.4 in.

- Test Article Damage Minimal
- Maximum Test Article Deflections
 - Permanent Set 0.1 in.
 - Dynamic 0.2 in.
 - Working Width..... 17.2 in.
- Transducer Data

Evaluation Criteria		Transducer		MASH 2016 Limit
		SLICE-1	SLICE-2 (primary)	
OIV ft/s	Longitudinal	-21.94	-21.83	±40
	Lateral	-24.65	-27.53	±40
ORA g's	Longitudinal	-4.00	-4.06	±20.49
	Lateral	-9.83	-7.17	±20.49
MAX ANGULAR DISP. deg.	Roll	17.0	1.37	±75
	Pitch	2.4	-2.8	±75
	Yaw	-44.6	-44.9	not required
THIV – ft/s		31.26	34.80	not required
PHD – g's		10.29	7.76	not required
ASI		1.71	1.88	not required

88

Figure 66. Summary of Test Results and Sequential Photographs, Test No. H34BR-2

7 SUMMARY, CONCLUSIONS, AND RECOMMENDATIONS

The objective of this project was to evaluate the HDOT 34-in. tall, Aesthetic Concrete Bridge Rail in accordance with the MASH 2016 TL-3 safety performance criteria. A summary of the testing and evaluation is shown in Table 11. The bridge rail system contained five concrete barrier segments consisting of two 11-ft long end segments and three 22-ft long interior barrier segments. The design compressive strength of the concrete was 4,000 psi. The existing concrete tarmac surface was milled to a depth of 2 in. and filled with low-strength concrete after removal of the formwork to replicate the wearing surface of a bridge deck. ASTM Grade 60 rebar was used for all longitudinal reinforcement and vertical reinforcement. Vertical reinforcement bars were anchored to an existing concrete tarmac on both the traffic-side and back-side faces to a depth of 8 in. and epoxied with Hilti HIT RE-500 V3 in order to develop the full tensile strength of the bar. Each barrier segment was separated by an expansion joint consisting of a ½-in. open gap that was filled with expansion joint sealant. The expansion joint assembly consisted of three 24-in. long no. 8 horizontal smooth rebar placed within PVC tubes and caps that were cast into the parapet. The test setup for both test nos. H34BR-1 and H34BR-2 were identical with the exception that the CIP locations varied per MASH 2016 guidelines.

In test no. H34BR-1, the 2,430-lb small car impacted HDOT's 34-in. tall, Aesthetic Concrete Bridge Rail at a speed of 62.4 mph, an angle of 25.7 degrees, and at a location $42^{9/16}$ in. upstream from the expansion joint between barrier nos. 3 and 4, thus resulting in a lateral impact force of 58.8 kips and an impact severity of 59.2 kip-ft. After impacting the barrier, the vehicle exited the system at a speed of 43.0 mph and an angle of 6.9 degrees. The vehicle was successfully redirected with moderate damage to the vehicle and minor damage to the concrete bridge rail. All vehicle decelerations, occupant compartment deformations, the maximum angular displacements, ORAs, and OIVs fell within the recommended safety limits established in MASH 2016. Therefore, test no. H34BR-1 was successful according to the safety performance criteria of MASH 2016 for test designation no. 3-10.

In test no. H34BR-2, the 5,001-lb pickup truck impacted HDOT's 34-in. tall, Aesthetic Concrete Bridge Rail at a speed of 64.0 mph, an angle of 25.4 degrees, and at a location $51^{15/16}$ in. upstream from the expansion joint between barrier nos. 2 and 3, thus resulting in a lateral impact force of 88.6 kips and an impact severity of 126.4 kip-ft. After impacting the barrier, the vehicle exited the system at a speed of 44.0 mph and an angle of 8.9 degrees. The vehicle was successfully redirected with moderate damage to the vehicle and minor damage to the concrete bridge rail. All vehicle decelerations, occupant compartment deformations, the maximum angular displacements, ORAs, and OIVs fell within the recommended safety limits established in MASH 2016. Therefore, test no. H34BR-2 was successful according to the safety performance criteria found in MASH 2016 for test designation no. 3-11. Based on the successful completion of the two full-scale crash tests required for evaluation of longitudinal barriers and bridge rails in MASH 2016, it is believed that the HDOT 34-in. tall, Aesthetic Concrete Bridge Rail meets the safety criteria for MASH 2016 TL-3.

It should be noted that both full scale crash tests were conducted on the length of need interior barrier segments, so the crashworthiness of the end segments and the transition buttresses were not evaluated in this report. It is recommended that end sections and buttresses be designed with similar or greater capacity to the bridge rail. Some minor cracking and damage was observed

on the barrier system near the ends of the bridge rail segments in both tests. Additionally, a long vertical crack that started at the bottom and extended to the top of the barrier was observed on the back side in test no. H34BR-2 due to loading of the dowel bars that transferred shear loads across the expansion joint. Cracking and damage of the barrier, especially near the expansion joint discontinuity, could weaken the bridge rail section and adversely affect its capacity and performance under secondary impacts. It is noted that reducing the spacing of the vertical reinforcement near the end sections of the barrier could potentially mitigate some of the cracking and damage that was observed in the full-scale crash tests and reduce the need for repair of the bridge rail. HDOT should consider reviewing the end sections of the bridge rail following accidents to determine if repair of the barrier is needed due to cracking similar to that observed in the testing herein.

Table 11. Summary of Safety Performance Evaluation

Evaluation Factors	Evaluation Criteria	Test No. H34BR-1	Test No. H34BR-2	
Structural Adequacy	A. Test article should contain and redirect the vehicle or bring the vehicle to a controlled stop; the vehicle should not penetrate, underride, or override the installation although controlled lateral deflection of the test article is acceptable.	S	S	
Occupant Risk	D. 1. Detached elements, fragments or other debris from the test article should not penetrate or show potential for penetrating the occupant compartment, or present an undue hazard to other traffic, pedestrians, or personnel in a work zone. 2. Deformations of, or intrusions into, the occupant compartment should not exceed limits set forth in Section 5.2.2 and Appendix E of MASH 2016.	S	S	
		S	S	
	F. The vehicle should remain upright during and after collision. The maximum roll and pitch angles are not to exceed 75 degrees.	S	S	
	H. Occupant Impact Velocity (OIV) (see Appendix A, Section A5.2.2 of MASH 2016 for calculation procedure) should satisfy the following limits:	S	S	
	Occupant Impact Velocity Limits			
	Component			Preferred
	Longitudinal and Lateral	30 ft/s	40 ft/s	
I. The Occupant Ridedown Acceleration (ORA) (see Appendix A, Section A5.2.2 of MASH 2016 for calculation procedure) should satisfy the following limits:	S	S		
Occupant Ridedown Acceleration Limits				
Component			Preferred	Maximum
Longitudinal and Lateral	15.0 g's	20.49 g's		
MASH 2016 Test Designation No.		3-10	3-11	
Final Evaluation (Pass or Fail)		Pass	Pass	

S – Satisfactory U – Unsatisfactory NA - Not Applicable

8 REFERENCES

1. Bullard, L.D., Sheikh N.M., Bligh R.P., Haug, R.R., Schutt, J.R., Storey, B.J., *Aesthetic Concrete Barrier Design*, NCHRP Report No. 554, Texas Transportation Institute, Texas A&M University, College Station, Texas, 2006.
2. White, M., Jewell, J., and Peter, R., *Crash Testing of Various Textured Barriers*, Contact No. F2001TL17, California Department of Transportation, Sacramento, California, 2002.
3. Ross, H. E., Jr., Sicking, D. L., Zimmer, R. A., and Michie, J. D., *Recommended Procedures for the Safety Performance Evaluation of Highway Features*, NCHRP Report No. 350, Transportation Research Board, National Research Council, Washington D. C., 1993
4. *Manual for Assessing Safety Hardware, Second Edition*, American Association of State Highway and Transportation Officials (AASHTO), Washington, D.C., 2016.
5. *Manual for Assessing Safety Hardware*, American Association of State Highway and Transportation Officials (AASHTO), Washington, D.C., 2009.
6. *Development of An Optimized Mash TL-4 Bridge Rail: MASH Test No. 4-12*, Report No. TRP-03-415-19, Midwest Roadside Safety Facility, University of Nebraska-Lincoln, Lincoln, Nebraska, DRAFT.
7. Hinch, J., Yang, T.L., and Owings, R., *Guidance Systems for Vehicle Testing*, ENSCO, Inc., Springfield, Virginia, 1986.
8. MacInnis, D., Cliff, W., and Ising, K., *A Comparison of the Moment of Inertia Estimation Techniques for Vehicle Dynamics Simulation*, SAE Technical Paper Series – 970951, Society of Automotive Engineers, Inc., Warrendale, Pennsylvania, 1997.
9. *Center of Gravity Test Code - SAE J874 March 1981*, SAE Handbook Vol. 4, Society of Automotive Engineers, Inc., Warrendale, Pennsylvania, 1986.
10. Society of Automotive Engineers (SAE), *Instrumentation for Impact Test – Part 1 – Electronic Instrumentation*, SAE J211/1 MAR95, New York City, New York, July, 2007.
11. *Vehicle Damage Scale for Traffic Investigators*, Second Edition, Technical Bulletin No. 1, Traffic Accident Data (TAD) Project, National Safety Council, Chicago, Illinois, 1971.
12. *Collision Deformation Classification – Recommended Practice J224 March 1980*, Handbook Volume 4, Society of Automotive Engineers (SAE), Warrendale, Pennsylvania, 1985.

9 APPENDICES

Appendix A. Material Specifications

Table A-1. Bill of Materials, Test Nos. H34BR-1 and H34BR-2

Item No.	Description	Material Specification	Reference No.
a1	Reinforced Concrete	Min. f _c = 4,000 psi [27.6 MPa] NE Mix 47BD	Product Code #470031PF Ticket #4213797
a2	Low-Strength Concrete Overlay	Concrete NE Mix 9019 CITY	Product Code #13013000 Ticket #1235150 Lab ID #URR-107, URR-108
b1	#5 [16] Rebar, 46 3/4" [1187] Total Unbent Length	ASTM A615 Gr. 60	H#57177640
b2	#5 [16] Rebar, 38 7/8" [987] Total Unbent Length	ASTM A615 Gr. 60	H#57177640
b3	#5 [16] Rebar, 259 1/2" [6591] Total Length	ASTM A615 Gr. 60	H#57177640
b4	#5 [16] Rebar, 127 3/4" [3245] Total Length	ASTM A615 Gr. 60	H#57177640
c1	#8 [25] Smooth Rebar, 24" [288] Total Length	ASTM A615 Gr. 60	H#256801
c2	1 1/4" [32] Dia. PVC Pipe	Schedule 80 PVC Gr. 12454	P#0472040 COC
c3	1 1/4" [32] PVC Cap	Schedule 80 PVC Gr. 12454	P#0470592 COC
c4	Epoxy Adhesive	Hilti HIT RE-500 V3	Hilti COC
c5	Expansion Joint Filler	AASHTO M33, M153, or M213	W.R. Meadows Seal Tight Fiber Expansion Joint that meets M213 Data Product Sheet
c6	Expansion Joint Sealant	AASHTO M173, M282, M301, ASTM D3581, or ASTM D5893	Carroll Invoice #LI061687 Item: "301NS"



Ready Mixed Concrete Company
6200 Cornhusker Hwy, Lincoln, NE 68529
Phone: (402) 434-1844 Fax: (402) 434-1877

Customer's Signature: _____

PLANT	TRUCK	DRIVER	CUSTOMER	PROJECT	TAX	PO NUMBER	DATE	TIME	TICKET
4	172	2818	62461				4/2/19		4213797
Customer UNL-MIDWEST ROADSIDE SAFETY			Delivery Address 4630 NW 36TH ST			Special Instructions AIRPARK / NW 36TH ST & W CUMINGSST / NORTH OF OLD GOODYEAR HANGARS			
LOAD QUANTITY	CUMULATIVE QUANTITY	ORDERED QUANTITY	PRODUCT CODE	PRODUCT DESCRIPTION		UOM	UNIT PRICE	EXTENDED PRICE	
9.00	9.00	9.00	470031PF	47BD (1PF)		yd	\$122.91	\$1,106.19	
Water Added On Job At Customer's Request:		SLUMP 4.00 in	Notes:			TICKET SUBTOTAL		\$1,106.19	
						SALES TAX		\$0.00	
						TICKET TOTAL		\$1,106.19	
						PREVIOUS TOTAL			
						GRAND TOTAL		\$1,106.19	

CAUTION FRESH CONCRETE

KEEP CHILDREN AWAY

Contains Portland cement. Freshly mixed cement, mortar, concrete or grout may cause skin injury. Avoid prolonged contact with skin. Always wear appropriate Personal Protective Equipment (PPE). In case of contact with eyes or skin, flush thoroughly with water. If irritation persists, seek medical attention promptly.

Terms & Conditions

This concrete is produced with the ASTM standard specifications for ready mix concrete. Strengths are based on a 3" slump. Drivers are not permitted to add water to the mix to exceed this slump, except under the authorization of the customer and their acceptance of any decrease in compressive strength and any risk of loss as a result thereof. Cylinder tests must be handled according to ACI/ASTM specifications and drawn by a licensed testing lab and/or certified technician. Ready Mixed Concrete Company will not deliver any product beyond any curb lines unless expressly told to do so by customer and customer assumes all liability for any personal or property damage that may occur as a result of any such directive. The purchaser's exceptions and claims shall be deemed waived unless made in writing within 3 days from time of delivery. In such a case, seller shall be given full opportunity to investigate any such claim. Seller's liability shall in no event exceed the purchase price of the materials against which any claims are made.

MATERIAL	DESCRIPTION	DESIGN QTY	REQUIRED	BATCHED	% VAR	% MOISTURE	ACTUAL WATER
CEM1PF	1PF CEMENT	658.0 lb	5922.0 lb	5905.0 lb	-0.29%		
G47B	47B GRAVEL	1975.0 lb	18107.6 lb	18060.0 lb	-0.26%	1.87% A	39.8 gl
L47B	47B ROCK	840.0 lb	7724.8 lb	7720.0 lb	-0.02%	2.18% A	19.7 gl
LRWR	POZZ 322N LOV	20.0 oz	180.0 oz	179.0 oz	-0.56%		
AIR	MB AE 200 air e	5.8 oz	52.2 oz	51.0 oz	-2.30%		
WATER	WATER	31.5 gl	232.9 gl	232.0 gl	-0.39%		232.0 gl

Actual Num Batches: 1 Manual 9:45:11

Load: 33635 lb Design W/C: 0.40 Water/Cement: 0.41 A Design Water: 283.5 gl Actual: 291.5 gl

Slump: 4.00 in # Water in Truck: 0.0 gl Adjust Water: 0.0 gl / Load Trim Water: 0.0 gl / CYDS

Actual W/C Ratio 0.41 Actual Water: 291 gl Batched Cement: 5905 lb Allowable Water: 0 lb To Add: 0.0 gl

Figure A-1. Reinforced Concrete, Test Nos. H34BR-1 and H34BR-2



LINCOLN OFFICE
 825 "M" Street Suite 100
 Lincoln, NE 68508
 Phone: (402) 479-2200
 Fax: (402) 479-2276

COMPRESSION TEST OF CYLINDRICAL CONCRETE SPECIMENS - 6x12

ASTM Designation: C 39

Client Name: Midwest Roadside Safety Facility
Project Name: Miscellaneous Concrete Testing
Placement Location: H34BR

Date: 15-Apr-19

Mix Designation:

Required Strength:

Laboratory Test Data

Laboratory Identification	Field Identification	Date Cast	Date Received	Date Tested	Days Cured in Field	Days Cured in Laboratory	Age of Test, Days	Length of Specimen, in.	Diameter of Specimen, in.	Cross-Sectional Area, sq.in.	Maximum Load, lbf	Compressive Strength, psi.	Required Strength, psi.	Type of Fracture	ASTM Practice for Capping Specimen
URR-107	E	4/2/2019	4/15/2019	4/15/2019	13	0	13	12	6.01	28.42	113,661	4,000		6	C 1231
URR-108	F	4/2/2019	4/15/2019	4/15/2019	13	0	13	12	6.01	28.42	120,934	4,260		6	C 1231

1 cc: Ms. Karla Lechtenberg
 Midwest Roadside Safety Facility

97

Remarks:

All concrete test data in this report was produced by Benesch personnel using ASTM Standard Methods and Practices unless otherwise noted.

Test results presented relate only to the concrete sampled by Benesch personnel as referenced above.

This report shall not be reproduced except in full, without the written approval of Alfred Benesch & Company.

Report Number 2147371060
 Page 1

Sketches of Types of Fractures

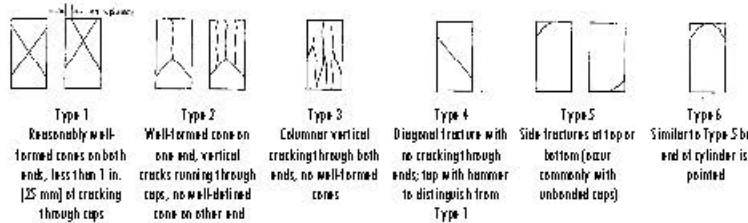

**ALFRED BENESCH & COMPANY
 CONSTRUCTION MATERIALS LABORATORY**

By: *Mark Peculier*

Figure A-2. Compression Test Cylindrical Concrete Specimen, Test Nos. H34BR-1 and H34BR-2



Ready Mixed Concrete Company
6200 Cornhusker Hwy, Lincoln, NE 68529
Phone: (402) 434-1844 Fax: (402) 434-1877

Customer's Signature: _____

PLANT	TRUCK	DRIVER	CUSTOMER	PROJECT	TAX	PO NUMBER	DATE	TIME	TICKET
01	108	7596	62461				4/15/19	10:53 AM	1235150
Customer UNL-MIDWEST ROADSIDE SAFETY				Delivery Address 4630 NW 36TH ST		Special Instructions AIRPARK / NW 36TH ST & W CUMINGSST / NORTH OF OLD GOODYEAR HANGARS			
LOAD QUANTITY	CUMULATIVE QUANTITY	ORDERED QUANTITY	PRODUCT CODE	PRODUCT DESCRIPTION		UOM	UNIT PRICE	EXTENDED PRICE	
2.00	2.00	2.00	13013000	SG3000		yd	\$112.50	\$225.00	
				MINIMUM HAUL				\$50.00	
Water Added On Job At Customer's Request:		SLUMP 4.00 in	Notes:		TICKET SUBTOTAL			\$275.00	
					SALES TAX			\$0.00	
					TICKET TOTAL			\$275.00	
					PREVIOUS TOTAL				
					GRAND TOTAL			\$275.00	

CAUTION FRESH CONCRETE
KEEP CHILDREN AWAY

Contains Portland cement. Freshly mixed cement, mortar, concrete or grout may cause skin injury. Avoid prolonged contact with skin. Always wear appropriate Personal Protective Equipment (PPE). In case of contact with eyes or skin, flush thoroughly with water. If irritation persists, seek medical attention promptly.

Terms & Conditions

This concrete is produced with the ASTM standard specifications for ready mix concrete. Strengths are based on a 3" slump. Drivers are not permitted to add water to the mix to exceed this slump, except under the authorization of the customer and their acceptance of any decrease in compressive strength and any risk of loss as a result thereof. Cylinder tests must be handled according to ACI/ASTM specifications and drawn by a licensed testing lab and/or certified technician. Ready Mixed Concrete Company will not deliver any product beyond any curb lines unless expressly told to do so by customer and customer assumes all liability for any personal or property damage that may occur as a result of any such directive. The purchaser's exceptions and claims shall be deemed waived unless made in writing within 3 days from time of delivery. In such a case, seller shall be given full opportunity to investigate any such claim. Seller's liability shall in no event exceed the purchase price of the materials against which any claims are made.

MATERIAL	DESCRIPTION	DESIGN QTY	REQUIRED	BATCHED	% VAR	% MOISTURE	ACTUAL WATER
CEM1	CEM 1/2	564 lb	1128 lb	1130 lb	0.18%		
G47B	47B GRAVEL	3003 lb	6070 lb	6420 lb	+ 5.77%	1.06% A	8 gl
AIR	MICRO AIR 200	1.50 oz	3.00 oz	3.00 oz	0.00%		
WATER	WATER	34.0 GL	63.3 GL	62.8 GL	-0.87%		62.8 gl

Actual Num Batches: 1 Manual 10:53:43

Load: 8074 lb Design W/C: 0.50 Water/Cement: 0.52 A Design Water: 68.0 gl Actual: 70.9 gl

Slump: 4.00 in # Water in Truck: 0.0 GL Adjust Water: 0.0 GL / Load Trim Water: 0.0 GL / CYDS

Actual W/C Ratio 0.52 Actual Water: 71 gl Batched Cement: 1130 lb Allowable Water: 0 lb To Add: 0.0 gl

Figure A-3. Low-Strength Concrete Overlay, Test Nos. H34BR-1 and H34BR-2



GERDAU

US-ML-KNOXVILLE
1919 TENNESSEE AVENUE N. W.
KNOXVILLE, TN 37921
USA

CERTIFIED MATERIAL TEST REPORT

CUSTOMER SHIP TO SIMCOTE INC 1645 RED ROCK SAINT PAUL, MN 55119 USA		CUSTOMER BILL TO SIMCOTE INC 1645 RED ROCK ROAD SAINT PAUL, MN 55119-6014 USA		GRADE 60 (420) TMX	SHAPE / SIZE Rebar / #5 (16MM)	DOCUMENT ID: 0000000000
SALES ORDER 6986112/000020		CUSTOMER MATERIAL N° CYCLE G		LENGTH 60'00"	WEIGHT 125,411 LB	HEAT / BATCH 57177640/02
CUSTOMER PURCHASE ORDER NUMBER MN-3702		BILL OF LADING 1326-000090862	DATE 10/09/2018	SPECIFICATION / DATE or REVISION ASTM A615/A615M-16		
CHEMICAL COMPOSITION						
C %	Mn %	P %	S %	Si %	Cr %	Ni %
0.33	0.58	0.014	0.059	0.17	0.39	0.14
					Mo %	Cu %
					0.050	0.012
						V %
						0.003
						CEqy A706
						0.46
MECHANICAL PROPERTIES						
YS PSI		YS MPa		UTS PSI		UTS MPa
82460		569		99320		685
					G/L Inch	G/L mm
					8.000	200.0
MECHANICAL PROPERTIES						
Elong. %		BendTest				
13.80		OK				
GEOMETRIC CHARACTERISTICS						
%Light	Def Hgt Inch	Def Gap Inch	DefSpace Inch			
4.51	0.045	0.118	0.370			
COMMENTS / NOTES						

99

The above figures are certified chemical and physical test records as contained in the permanent records of company. We certify that these data are correct and in compliance with specified requirements. This material, including the billets, was melted and manufactured in the USA. CMTR complies with EN 10204 3.1.

Bhaskar BHASKAR YALAMANCHILI
QUALITY DIRECTOR
Phone: (409) 267-1071 Email: Bhaskar.Yalamanchili@gerdau.com

Jim Hall JIM HALL
QUALITY ASSURANCE MGR
Phone: 865-202-5972 Email: Jim.hall@gerdau.com

Figure A-4. #5 Rebar, Test Nos. H34BR-1 and H34BR-2



P. O. Box 911
Seguin, Texas 78156-0911
(830) 372-8200

CERTIFIED MILL TEST REPORT
For additional copies call
(830) 372-8485

We hereby certify that the test results presented here are accurate and conform to the reported grade.

Daniel J. Schacht
Daniel J. Schacht
Quality Assurance Manager

HEAT NO.: 256801		SECTION: RD 1x45'2"		RD 25.4mm x13.768		GRADE: ASTM A615-05a GRADE 60		ASTM A615M-05a GRADE 420		S O L D T O		A B C COATING - TULSA		P O BOX 9693		TULSA, OK 74157-		S H I P T O		A B C COATING CO		2236 SOUTH YUKON AVE.		TULSA, OK 74107-		SHIP#: 102028/60		BOL #: 480684		INV #: 8000705806		CUST PO#:		CUST P/N:						
CHEMICAL ANALYSIS										PROPERTIES																														
		MECHANICAL		TEST I				TEST				TEST																												
%				IMPERIAL		METRIC		IMPERIAL		METRIC		IMPERIAL		METRIC																										
C	0.28	Yield Strength Tensile Strength Elongation Gauge Length Reduction of Area Bend Test Diameter Charpy Impact Test Temp Sample Size Orientation Hardness		78.3	KSI	539.9	MPA																																	
Mn	1.26			111.6	KSI	769.5	MPA																																	
P	0.018			18	%	18	%																																	
S	0.031			8	INS	203	MM																																	
Si	0.19			OK																																				
Cu	0.49			7.90	INS	200.41	MM																																	
Cr	0.16																																							
Ni	0.14																																							
Mo	0.040																																							
Cb	0.011																																							
V	0.020																																							
Sn	0.015																																							
B	0.0004																																							
Ti	0.001																																							
C.Eq.	0.52																																							
JOMINY RESULTS - Rockwell C hardness at 1/16th inch increments												GRAIN SIZE				INCLUSION RATING																								
1	2	3	4	5	6	7	8	9	10	11	12	METHOD				METHOD																								
																TYPE																								
13	14	15	16	18	20	22	24	26	28	30	32	RESULT				SIZE																								
																T H T H T H T H																								

100% MELTED AND MANUFACTURED IN THE USA AND FREE OF MERCURY CONTAMINATION IN THE PROCESS
REMARKS:

AASHTO M 31MM 31-95

State of Texas, County of Guadalupe

MAY-17-2007 09:29
Page 1 OF 1

Figure A-5. #8 Rebar, Test Nos. H34BR-1 and H34BR-2

100

October 21, 2019
MWRSF Report No. TRP-03-420-19



Fastenal Company
P.O Box 1286
WINONA, MN 55987-1286

Invoice

Date	Reference	Page
2/13/19	NELIN339481	1
DUE DATE: 03/15/2019		

Cust. No. NELIN2067
Cust. P.O. H34BR-1
Job No. Item# c2, c3

The store serving you is
3201 N. 23rd Street STE 1

LINCOLN, NE 68521
Phone #: (402)476-7900
Fax #: 402/476-7958

Contract No:
8497 & 15002 OC
Ship To
Picked up at Fastenal Store.

Sold To
UNL TRANSPORTATION/Midwest Roadside Safe
1931 NORTH ANTELOPE VALLEY PKWY
LINCOLN, NE 68588
402-472-7937; 402-472-8660(Fax)

Authorized Purchaser: Jim Holloway

This Order and Document are subject to the "Terms of Purchase" posted on www.fastenal.com.

Line No.	Quantity Ordered	Quantity Shipped	Quantity Backorder	Description	Control No.	Part No.	Price / Hundred	Amount
1	2	2	0	1 1/4 S80PVC Pipe10	blca2561	0472040	1,801.5000	36.03 G
2	15	15	0	1-1/4 SOCK CAP PVC	GFharv	0470592	434.7000	65.21 G

Visa Account # XXXXXXXXXXXX6926 Exp XX/XX

Cardmember acknowledges receipt of goods or services in the amount of the total shown hereon and agrees to perform the obligations set forth by the cardmember's agreement with the issuer.

X _____
Card Member Signature

Received By

Tax Exemption
Government

Subtotal	101.24
Shipping & Handling	0.00
State Tax	0.00
County Tax	0.00
City Tax	0.00
TOTAL USD	101.24

Comments
Contact: WEBORD CONTRACT:8497 & 15002 OC

If you re-package or re-sell this product, you are required to maintain integrity of Country of Origin to the consumer of this product.

Reasonable collection and attorneys fees will be assessed to all accounts placed for collection. No materials accepted for return without our permission.

X indicates part is a hazardous material

* indicates part was sold at a promotional or special discount price

This is your invoice.
All discrepancies must be reported within 10 days.

Thank You !

FORM - N13

Figure A-6. 1¼-in. Dia. PVC Pipe and 1¼-in. PVC Cap, Test Nos. H34BR-1 and H34BR-2



P.O. Box 21148
Tulsa, OK 74121
Phone (918) 252-6000
Fax No. (918) 252-6520

Certified Quality and
Environmental Systems

ISO 9001 / ISO 14001
Reg. No. 12455-03

Date: 12/13/2016

Subject: Certificate of Conformance

Product: HIT RE-500 V3 Adhesive

To Whom it May Concern:

This is to certify that the HIT-RE 500 V3 is a high-strength, slow cure two-part epoxy adhesive contained in two cartridges separating the resin from the hardener.

Additionally, this certifies that the product has been seismically and cracked concrete qualified as represented in ICC-ES report ESR- 3814.

Sincerely,

Hilti, Inc.

5400 South 122 East Avenue

Tulsa, Oklahoma 74146

800-879-8000

800-879-7000 fax

US-Sales@hilti.com

Figure A-7. Epoxy Adhesive, Test Nos. H34BR-1 and H34BR-2

Pecora 301 NS

Non-Sag Silicone Highway & Pavement Joint Sealant

Specification Data Sheet

PECORA CORPORATION
Architectural/Weatherproofing Products
U.S.A. • since 1862

1. BASIC USES
Sealing of transverse contraction and expansion joints, longitudinal, centerline and shoulder joints in Portland cement concrete (PCC) and asphalt.

2. MANUFACTURER
Pecora Corporation
165 Wambold Road
Harleysville, PA 19438
Phone: 215-723-6051
800-523-6688
Fax: 215-721-0286
Website: www.pecora.com

3. PRODUCT DESCRIPTION
Pecora 301 NS Silicone Pavement Sealant is a one part, ultra low modulus product designed for sealing joints in concrete or asphalt pavement. It has excellent unprimed adhesion to concrete, metal and asphalt substrates, superior weather resistance and remains flexible at extremely low temperatures.

Pecora 301 NS Silicone Pavement Sealant is a non-sag product designed for applications on flat and sloped surfaces.

- Advantages:**
- Reduces pavement deterioration by restricting surface water penetration into underlying base and sub base layers.
 - Convenient one component, neutral moisture curing system.
 - Ultra low modulus resulting in high movement capability.
 - Ease of application with standard automated bulk dispensing equipment such as Graco or Pyles.
 - VOC compliant.
 - Primerless adhesion to concrete and asphalt.
 - Aids in elimination of non-compressibles entering expansion joints.

- Limitations:**
Pecora 301 NS Silicone Pavement Sealant should not be used:
- for continuous water immersion conditions.
 - when ambient temperatures is below 40°F (4°C) or above 120°F (49°C).
 - flush with traffic surface. **(Sealant must be recessed below surface.)**
 - for applications requiring support of hydrostatic pressures.
 - with solvents for dilution purposes.
 - with concrete that is cured less than 7 days.

- with newly applied asphalt until cooled to ambient temperature (usually 24-48 hours).
- as a structural component or in longitudinal joints greater than 3/4" in width that are intended to be used as a constant travelling surface.

PACKAGING

- 30 fl. oz. (887ml) cartridges
- 20 fl. oz. (592ml) sausages
- 4.5 gallon pails (17.0L)
- 50 gallon drum (188.9L)

Color: pavement gray

SEALANT COVERAGE CHART RECESS GUIDELINES						
Joint Width (inches)	Sealant Depth (inches)	Recess (inches)	Backer Rod Diameter (in)	Minimum Joint Depth (in)	Linear ft./gal	
1/4	1/4	1/8	3/8	3/4	308	
3/8	1/4	1/8	1/2	7/8	205	
1/2	1/4	1/8	5/8	1-1/4	154	
3/4	3/8	1/4	7/8	1-1/4	68	
1.0	1/2	1/4	1-1/4	2	38	

TABLE 1: TYPICAL UNCURED PROPERTIES		
Test Property	Value	Test Procedure
Cure Through (days)	7	0.5" cross section
Extrusion Rate (grams/min)	90-250	Mil-S-8802
Rheological Properties	non-sag	
Tack Free Time (mins)	60	ASTM C679
VOC Content (g/L)	50	ASTM D3960

TABLE 2: TYPICAL CURED PROPERTIES (After 7 days cure at 77°F (25°C), 50% RH)		
Test Property	Value	Test Procedure
Adhesion, minimum elongation		ASTM D5329*
Asphalt	500	
Concrete	500	
Metal	500	
Elongation (%)	>1400	ASTMD412
Resilience (%)	>95	ASTM D5329
Stress @ 150% Elongation (psi)	22	ASTMD412
Hardness, maximum		
21 day cure (Shore 00) Joint	60	ASTM C661
Movement Capability		
+100/-50%; 10 cycles	Pass	ASTM C719

*modified section 14

Since Pecora architectural sealants are applied to varied substrates under diverse environmental conditions and construction situations it is recommended that substrate testing be conducted prior to application.

Figure A-8. Expansion Joint Sealant, Test Nos. H34BR-1 and H34BR-2

Appendix B. Vehicle Center of Gravity Determination

Date: <u>4/17/2019</u>	Test Name: <u>H34BR-1</u>	VIN: <u>KMHCHN46C39U373073</u>	
Year: <u>2009</u>	Make: <u>Hyundai</u>	Model: <u>Accent</u>	

Vehicle CG Determination

Vehicle Equipment	Weight (lb)
+ Unballasted Car (Curb)	2511
+ Hub	19
+ Brake activation cylinder & frame	9
+ Pneumatic tank (Nitrogen)	30
+ Strobe/Brake Battery	5
+ Brake Receiver/Wires	6
+ CG Plate including DAQ	16
- Battery	-32
- Oil	-10
- Interior	-74
- Fuel	-55
- Coolant	-8
- Washer fluid	-9
+ Water Ballast (In Fuel Tank)	0
+ Onboard Supplemental Battery	0
TDAS	17

Note: (+) is added equipment to vehicle, (-) is removed equipment from vehicle

Estimated Total Weight (lb) 2425

Vehicle Dimensions for C.G. Calculations

Wheel Base: <u>98.5</u> in.	Front Track Width: <u>57.375</u> in.
Roof Height: <u>57.5</u> in.	Rear Track Width: <u>57.125</u> in.

Center of Gravity	1100C MASH Targets	Test Inertial	Difference
Test Inertial Weight (lb)	2420 ± 55	2430	10.0
Longitudinal CG (in.)	39 ± 4	36.157	-2.843
Lateral CG (in.)	NA	-0.66	NA
Vertical CG (in.)	NA	22.573	NA

Note: Long. CG is measured from front axle of test vehicle
Note: Lateral CG measured from centerline - positive to vehicle right (passenger) side

	Left	Right
Front	799	789
Rear	483	440
FRONT	1588	lb
REAR	923	lb
TOTAL	<u>2511</u>	lb

	Left	Right
Front	783	755
Rear	460	432
FRONT	1538	lb
REAR	892	lb
TOTAL	<u>2430</u>	lb

Figure B-1. Vehicle Mass Distribution, Test No. H34BR-1

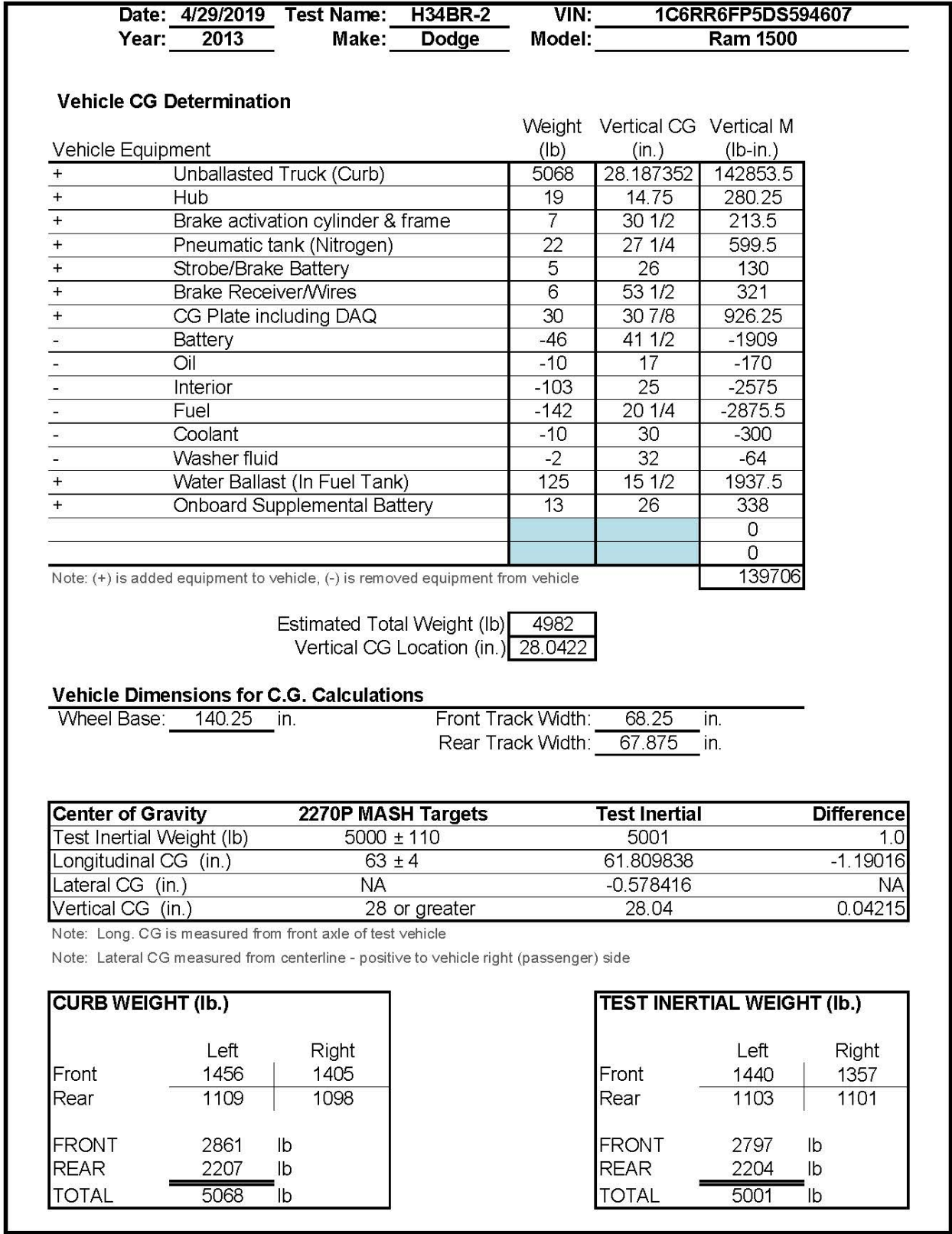

Figure B-2. Vehicle Mass Distribution, Test No. H34BR-2

Appendix C. Vehicle Deformation Records

Date: 4/17/2019
Year: 2009

Test Name: H34BR-1
Make: Hyundai

VIN: KMHCN46C39U973073
Model: Accent

VEHICLE DEFORMATION
PASSENGER SIDE FLOOR PAN - SET 1

	POINT	Pretest X (in.)	Pretest Y (in.)	Pretest Z (in.)	Posttest X (in.)	Posttest Y (in.)	Posttest Z (in.)	ΔX^A (in.)	ΔY^A (in.)	ΔZ^A (in.)	Total Δ (in.)	Crush ^B (in.)	Directions for Crush ^C
TOE PAN - WHEEL WELL (X, Z)	1	62.2228	19.1072	4.6685	62.5407	17.5332	4.2848	-0.3179	1.5740	0.3837	1.6510	0.3837	Z
	2	62.4557	23.8043	4.3620	61.6897	21.8043	2.5968	0.7660	2.0000	1.7652	2.7754	1.9242	X, Z
	3	62.3835	29.1016	4.3197	61.7316	27.0928	2.9230	0.6519	2.0088	1.3967	2.5320	1.5413	X, Z
	4	61.7135	33.9025	3.7596	60.8783	31.9143	2.2440	0.8352	1.9882	1.5156	2.6358	1.7305	X, Z
	5	59.8859	37.8209	2.6444	58.4197	35.4020	1.9978	1.4662	2.4189	1.2466	3.0911	1.9245	X, Z
	6	58.1564	18.5630	5.3486	58.7025	16.9243	5.0315	-0.5461	1.6387	0.3171	1.7562	0.3171	Z
	7	59.0277	23.3644	6.5202	58.4152	21.3553	4.8575	0.6125	2.0091	1.6627	2.6788	1.7719	X, Z
	8	59.0020	28.7901	6.3531	58.5077	26.7973	5.2148	0.4943	1.9928	1.1383	2.3476	1.2410	X, Z
	9	58.7699	33.6637	6.3321	58.4157	31.6272	5.3277	0.3542	2.0365	1.0044	2.2982	1.0650	X, Z
	10	58.1579	38.0279	6.1370	57.6573	35.8550	5.2456	0.5006	2.1729	0.8914	2.4014	1.0223	X, Z
FLOOR PAN (Z)	11	54.2686	18.5381	5.6554	54.8359	17.6073	4.8421	-0.5673	0.9308	0.8133	1.3600	0.8133	Z
	12	54.6217	23.0866	7.6362	54.1470	21.4985	6.0631	0.4747	1.5881	1.5731	2.2852	1.5731	Z
	13	54.4739	28.6834	7.4892	54.1961	26.7751	6.6865	0.2778	1.9083	0.8027	2.0888	0.8027	Z
	14	54.3649	33.3551	7.6956	54.3140	31.4298	6.9506	0.0509	1.9253	0.7450	2.0650	0.7450	Z
	15	54.0317	37.8411	7.6929	54.1406	36.0188	6.9897	-0.1089	1.8223	0.7032	1.9563	0.7032	Z
	16	50.1894	18.3970	5.8229	50.6520	17.5773	5.1189	-0.4626	0.8197	0.7040	1.1754	0.7040	Z
	17	50.4716	22.4934	8.3179	49.9961	21.7761	5.2067	0.4755	0.7173	3.1112	3.2280	3.1112	Z
	18	50.2219	28.4709	7.7677	49.9874	26.7771	7.1997	0.2345	1.6938	0.5680	1.8018	0.5680	Z
	19	50.0475	33.2124	8.0970	49.7436	36.0420	7.3671	0.3039	-2.8296	0.7299	2.9380	0.7299	Z
	20	49.7131	37.7011	8.1010	46.5785	17.2686	5.6737	3.1346	20.4325	2.4273	20.8136	2.4273	Z
	21	45.9748	18.2578	6.0232	45.6864	21.8553	7.1271	0.2884	-3.5975	-1.1039	3.7741	-1.1039	Z
	22	45.6924	22.5251	8.4725	45.4736	26.5637	7.7222	0.2188	-4.0386	0.7503	4.1135	0.7503	Z
	23	45.7217	27.9969	8.0016	45.5295	31.2158	7.6358	0.1922	-3.2189	0.3658	3.2453	0.3658	Z
	24	45.6073	32.7613	8.1034	45.6065	35.8361	7.8644	0.0008	-3.0748	0.2390	3.0841	0.2390	Z
	25	45.5490	37.4554	8.3361	45.5940	35.8127	7.8959	-0.0450	1.6427	0.4402	1.7013	0.4402	Z
	26	41.2701	18.1016	6.2399	41.7577	17.2182	6.0440	-0.4876	0.8834	0.1959	1.0279	0.1959	Z
	27	41.2429	22.0508	8.4407	41.4601	21.5234	7.5805	-0.2172	0.5274	0.8602	1.0321	0.8602	Z
	28	40.9029	27.9198	8.0482	40.6217	26.6388	8.0654	0.2812	1.2810	-0.0172	1.3116	-0.0172	Z
	29	40.7755	32.3547	8.1217	40.7078	31.0799	7.9822	0.0677	1.2748	0.1395	1.2842	0.1395	Z
	30	40.5645	37.3999	8.2543	40.6013	36.0140	8.2418	-0.0368	1.3859	0.0125	1.3864	0.0125	Z

^A Positive values denote deformation as inward toward the occupant compartment, negative values denote deformations outward away from the occupant compartment.

^B Crush calculations that use multiple directional components will disregard components that are negative and only include positive values where the component is deforming inward toward the occupant compartment.

^C Direction for Crush column denotes which directions are included in the crush calculations. If "NA" then no intrusion is recorded, and Crush will be 0.

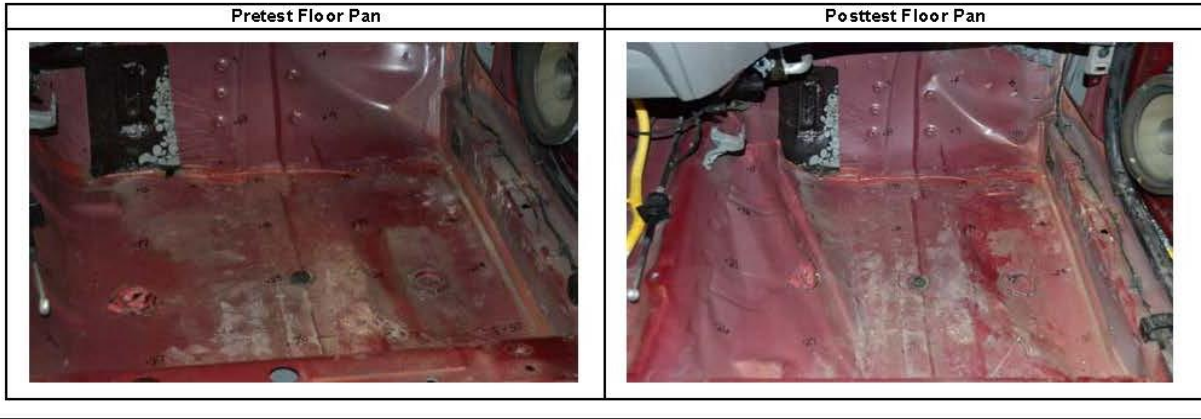

Figure C-1. Floor Pan Deformation Data – Set 1, Test No. H34BR-1

Date: 4/17/2019
Year: 2009

Test Name: H34BR-1
Make: Hyundai

VIN: KMHCCN46C39U373073
Model: Accent

VEHICLE DEFORMATION
PASSENGER SIDE FLOOR PAN - SET 2

	POINT	Pretest X (in.)	Pretest Y (in.)	Pretest Z (in.)	Posttest X (in.)	Posttest Y (in.)	Posttest Z (in.)	ΔX^A (in.)	ΔY^A (in.)	ΔZ^A (in.)	Total Δ (in.)	Crush ^B (in.)	Directions for Crush ^C
TOE PAN - WHEEL WELL (X, Z)	1	63.1369	-4.4307	4.2883	63.1928	-5.9047	5.8045	-0.0559	-1.4740	-1.5162	2.1153	0.0000	NA
	2	63.5791	0.2520	3.9920	62.5953	-1.5666	4.1797	0.9838	1.8186	-0.1877	2.0762	0.9838	X
	3	63.7453	5.5473	3.9635	62.8662	3.7069	4.6189	0.8791	1.8404	-0.6554	2.1423	0.8791	X
	4	63.2885	10.3751	3.4200	62.2567	8.5751	4.0139	1.0318	1.8000	-0.5939	2.1581	1.0318	X
	5	61.6319	14.3749	2.3271	59.9896	12.1883	3.1598	1.6423	2.1866	-0.8927	2.8586	1.6423	X
	6	59.0547	-4.7932	4.9945	59.3075	-6.3504	6.4093	-0.2528	-1.5572	-1.4148	2.1191	0.0000	NA
	7	60.1492	-0.0392	6.1723	59.2279	-1.9083	6.3195	0.9213	-1.8691	-0.1472	2.0890	0.9213	X
	8	60.3668	5.3826	6.0190	59.5552	3.5156	6.7948	0.8116	1.8670	-0.7758	2.1786	0.8116	X
	9	60.3543	10.2618	6.0118	59.6789	8.3415	7.0066	0.6754	1.9203	-0.9948	2.2657	0.6754	X
	10	59.9383	14.6497	5.8319	59.1166	12.6005	6.9886	0.8217	2.0492	-1.1567	2.4925	0.8217	X
FLOOR PAN (Z)	11	55.1719	-4.6439	5.3276	55.4848	-5.4862	6.1050	-0.3129	-0.8423	-0.7774	1.1882	-0.7774	Z
	12	55.7427	-0.1214	7.3174	54.9317	-1.5921	7.3843	0.8110	-1.4707	-0.0669	1.6808	-0.0669	Z
	13	55.8462	5.4767	7.1855	55.1990	3.6634	8.1204	0.6472	1.8133	-0.9349	2.1403	-0.9349	Z
	14	55.9491	10.1480	7.4044	55.5190	8.3017	8.4868	0.4301	1.8463	-1.0824	2.1830	-1.0824	Z
	15	55.8183	14.6445	7.4152	55.5531	12.8921	8.6171	0.2652	1.7524	-1.2019	2.1414	-1.2019	Z
	16	51.0916	-4.6016	5.5225	51.2967	-5.3287	6.2409	-0.2051	-0.7271	-0.7184	1.0425	-0.7184	Z
	17	51.5747	-0.5291	8.0258	50.8297	-1.1066	6.3955	0.7450	-0.5775	1.6303	1.8832	1.6303	Z
	18	51.5909	5.4551	7.4924	50.9796	3.8495	8.4924	0.6113	1.6056	-1.0000	1.9879	-1.0000	Z
	19	51.6324	10.1987	7.8347	51.1513	13.1107	8.8475	0.4811	-2.9120	-1.0128	3.1204	-1.0128	Z
	20	51.5005	14.6979	7.8522	47.1968	-5.4600	6.6524	4.3037	20.1579	1.1998	20.6471	1.1998	Z
	21	46.8765	-4.5514	5.7510	46.4644	-0.8663	8.1718	0.4121	3.6851	-2.4208	4.4283	-2.4208	Z
	22	46.8030	-0.2827	8.2129	46.4454	3.8343	8.8589	0.3576	4.1170	-0.6460	4.1827	-0.6460	Z
	23	47.0756	5.1836	7.7555	46.7155	8.4797	8.8729	0.3601	-3.2961	-1.1174	3.4989	-1.1174	Z
	24	47.1765	9.9479	7.8701	46.9945	13.0862	9.2015	0.1820	-3.1383	-1.3314	3.4139	-1.3314	Z
	25	47.3313	14.6393	8.1150	46.9798	13.0627	9.2322	0.3515	1.5766	-1.1172	1.9640	-1.1172	Z
	26	42.1711	-4.4962	5.9993	42.3687	-5.2952	6.8600	-0.1976	-0.7990	-0.8607	1.1909	-0.8607	Z
	27	42.3364	-0.5561	8.2101	42.2144	-1.0118	8.4764	0.1220	-0.4557	-0.2663	0.5417	-0.2663	Z
	28	42.2586	5.3234	7.8347	41.5930	4.1263	9.0410	0.6656	1.1971	-1.2063	1.8252	-1.2063	Z
	29	42.3316	9.7593	7.9201	41.8836	8.5596	9.0547	0.4480	1.1997	-1.1346	1.7109	-1.1346	Z
	30	42.3489	14.8084	8.0668	41.9925	13.4873	9.4149	0.3564	1.3211	-1.3481	1.9209	-1.3481	Z

^A Positive values denote deformation as inward toward the occupant compartment, negative values denote deformations outward away from the occupant compartment.

^B Crush calculations that use multiple directional components will disregard components that are negative and only include positive values where the component is deforming inward toward the occupant compartment.

^C Direction for Crush column denotes which directions are included in the crush calculations. If "NA" then no intrusion is recorded, and Crush will be 0.



Figure C-2. Floor Pan Deformation Data – Set 2, Test No. H34BR-1

Date: 4/29/2019 Test Name: H34BR-2 VIN: 1C6RR6FP5DS594607
Year: 2013 Make: Dodge Model: Ram 1500

VEHICLE DEFORMATION
PASSENGER SIDE FLOOR PAN - SET 1

	POINT	Pretest X (in.)	Pretest Y (in.)	Pretest Z (in.)	Posttest X (in.)	Posttest Y (in.)	Posttest Z (in.)	ΔX^A (in.)	ΔY^A (in.)	ΔZ^A (in.)	Total Δ (in.)	Crush ^B (in.)	Directions for Crush ^C
TOE PAN - WHEEL WELL (X, Z)	1	45.4518	16.0528	-3.3983	44.7297	16.4077	-3.5119	0.7221	-0.3549	0.1136	0.8126	0.7310	X, Z
	2	46.3644	20.4162	-0.8591	45.5467	20.7215	-0.6651	0.8177	-0.3053	-0.1940	0.8941	0.8177	X
	3	47.5516	24.4544	2.3446	46.7572	23.5253	2.8258	0.7944	0.9291	-0.4812	1.3137	0.7944	X
	4	47.5432	29.4845	2.3228	43.5259	26.5230	0.3549	4.0173	2.9615	1.9679	5.3649	4.4734	X, Z
	5	47.3800	34.0922	2.1880	42.9911	30.5106	0.1759	4.3889	3.5816	2.0121	6.0116	4.8281	X, Z
	6	41.9661	15.5753	-1.4025	41.5231	15.5244	-1.5396	0.4430	0.0509	0.1371	0.4665	0.4637	X, Z
	7	43.0012	19.7473	1.0606	42.2544	19.6262	1.1571	0.7468	0.1211	-0.0965	0.7627	0.7468	X
	8	44.1936	24.3256	4.2231	43.5961	23.7193	4.9483	0.5975	0.6063	-0.7252	1.1183	0.5975	X
	9	43.9878	29.2264	4.3319	42.4591	27.9882	4.1564	1.5287	1.2382	0.1755	1.9751	1.5387	X, Z
	10	43.8494	34.1570	4.4015	41.5657	30.3755	4.2451	2.2837	3.7815	0.1564	4.4203	2.2890	X, Z
FLOOR PAN (Z)	11	38.5765	14.9707	0.6841	38.3980	14.3799	0.8459	0.1785	0.5908	-0.1618	0.6380	-0.1618	Z
	12	39.7622	18.7200	3.8444	38.9631	18.3151	3.8408	0.7991	0.4049	0.0036	0.8958	0.0036	Z
	13	40.3841	24.0436	5.4755	39.8229	23.5990	6.1852	0.5612	0.4446	-0.7097	1.0081	-0.7097	Z
	14	40.2968	29.0599	5.4894	39.7933	28.3997	6.9666	0.5035	0.6602	-1.4772	1.6945	-1.4772	Z
	15	40.1544	34.0775	5.5112	38.4862	32.1050	4.9640	1.6682	1.9725	0.5472	2.6407	0.5472	Z
	16	34.6489	14.2860	2.5229	34.5336	13.9582	2.6990	0.1153	0.3278	-0.1761	0.3896	-0.1761	Z
	17	35.4466	18.6542	5.4343	35.3143	18.7705	4.6239	0.1323	-0.1163	0.8104	0.8293	0.8104	Z
	18	35.6205	24.0745	5.4536	34.9601	23.9197	5.8068	0.6604	0.1548	-0.3532	0.7647	-0.3532	Z
	19	35.5855	29.3890	5.4656	35.1127	28.7718	7.7826	0.4728	0.6172	-2.3170	2.4440	-2.3170	Z
	20	35.2734	34.0674	5.5059	34.3098	32.2318	6.9124	0.9636	1.8356	-1.4065	2.5052	-1.4065	Z
	21	30.5020	14.2624	2.9878	30.2873	14.4177	3.0516	0.2147	-0.1553	-0.0638	0.2726	-0.0638	Z
	22	31.2364	18.8321	5.4312	31.0373	18.8497	4.9682	0.1991	-0.0176	0.4630	0.5043	0.4630	Z
	23	31.2171	24.1221	5.4368	31.0076	24.1425	5.2141	0.2095	-0.0204	0.2227	0.3064	0.2227	Z
	24	31.0420	29.3829	5.4687	30.7547	29.0813	6.9469	0.2873	0.3016	-1.4782	1.5358	-1.4782	Z
	25	30.8019	34.2325	5.4765	30.0654	33.2626	7.6558	0.7365	0.9699	-2.1793	2.4965	-2.1793	Z
	26	26.1795	14.2921	3.1532	25.9751	14.9164	3.1580	0.2044	-0.6243	-0.0048	0.6569	-0.0048	Z
	27	25.8715	18.9109	4.6509	25.7334	19.0002	5.1751	0.1381	-0.0893	-0.5242	0.5494	-0.5242	Z
	28	25.8141	24.2391	4.4434	25.6824	24.3425	5.1411	0.1317	-0.1034	-0.6977	0.7175	-0.6977	Z
	29	25.9015	29.6005	4.6821	25.7690	29.6640	5.6500	0.1325	-0.0635	-0.9679	0.9790	-0.9679	Z
	30	25.7642	34.1520	4.5479	25.5143	34.1603	6.4641	0.2499	-0.0083	-1.9162	1.9324	-1.9162	Z

^A Positive values denote deformation as inward toward the occupant compartment, negative values denote deformations outward away from the occupant compartment.

^B Crush calculations that use multiple directional components will disregard components that are negative and only include positive values where the component is deforming inward toward the occupant compartment.

^C Direction for Crush column denotes which directions are included in the crush calculations. If "NA" then no intrusion is recorded, and Crush will be 0.

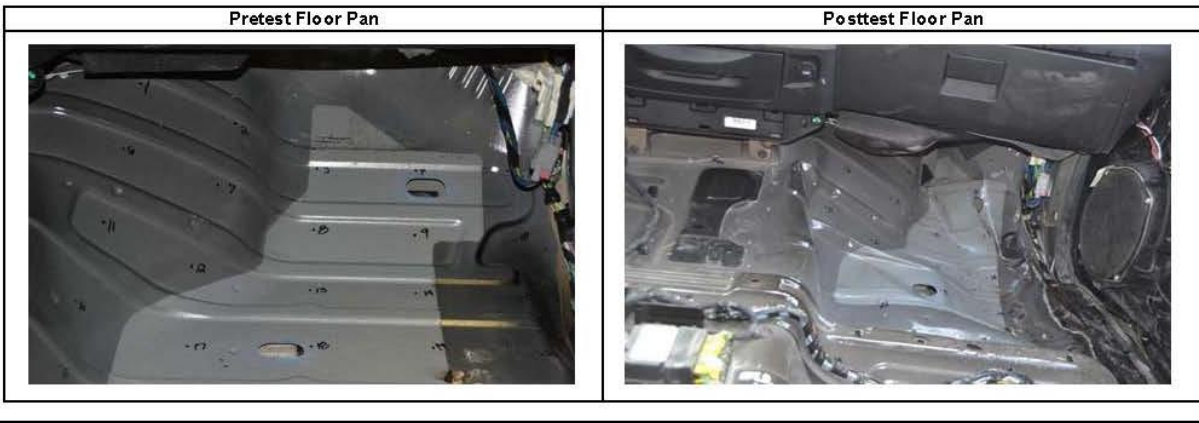

Figure C-3. Floor Pan Deformation Data – Set 1, Test No. H34BR-2

Date: 4/29/2019 Test Name: H34BR-2 VIN: 1C6RR6FP5DS594607
Year: 2013 Make: Dodge Model: Ram 1500

VEHICLE DEFORMATION
PASSENGER SIDE FLOOR PAN - SET 2

	POINT	Pretest X (in.)	Pretest Y (in.)	Pretest Z (in.)	Posttest X (in.)	Posttest Y (in.)	Posttest Z (in.)	ΔX^A (in.)	ΔY^A (in.)	ΔZ^A (in.)	Total Δ (in.)	Crush ^B (in.)	Directions for Crush ^C
TOE PAN - WHEEL WELL (X, Z)	1	53.0747	-3.7622	-7.7421	52.5423	-3.8391	-8.6328	0.5324	-0.0769	0.8907	1.0405	1.0377	X, Z
	2	54.0597	0.5888	-5.2088	53.4853	0.5060	-5.8739	0.5744	0.0828	0.6651	0.8827	0.8788	X, Z
	3	55.3187	4.6110	-2.0124	54.8101	3.3454	-2.4540	0.5086	1.2656	0.4416	1.4337	0.6736	X, Z
	4	55.3774	9.6408	-2.0349	51.5791	6.3557	-4.9100	3.7983	3.2861	2.8751	5.7866	4.7637	X, Z
	5	55.2752	14.2502	-2.1696	51.1053	10.3482	-5.1440	4.1699	3.9020	2.9744	6.4390	5.1220	X, Z
	6	49.6941	-4.1929	-5.7269	49.3617	-4.6376	-6.5839	0.2324	-0.4447	0.8570	0.9931	0.8880	X, Z
	7	50.6987	-0.0349	-3.2702	50.2126	-0.5054	-3.9698	0.4861	-0.4705	0.6996	0.9732	0.8519	X, Z
	8	51.9698	4.5273	-0.1152	51.6953	3.6256	-0.2734	0.2745	0.9017	0.1582	0.9557	0.3168	X, Z
	9	51.8302	9.4305	-0.0060	50.6119	7.8993	-1.1129	1.2183	1.5312	1.1069	2.2481	1.6461	X, Z
	10	51.7582	14.3624	0.0636	49.7591	10.3022	-1.0460	1.9991	4.0602	1.1096	4.6597	2.2864	X, Z
FLOOR PAN (Z)	11	46.2084	-4.7520	-3.6213	46.2665	-5.6918	-4.1191	-0.0581	-0.9398	0.4978	1.0651	0.4978	Z
	12	47.4618	-1.0185	-0.4682	46.9545	-1.7187	-1.2008	0.5073	-0.7002	0.7326	1.1333	0.7326	Z
	13	48.1640	4.2964	1.1585	47.9459	3.5875	1.0391	0.2181	0.7089	0.1194	0.7512	0.1194	Z
	14	48.1439	9.3134	1.1721	48.0094	8.4000	1.7418	0.1345	0.9134	-0.5697	1.0849	-0.5697	Z
	15	48.0687	14.3324	1.1939	46.7228	12.0935	-0.2954	1.3459	2.2389	1.4893	3.0070	1.4893	Z
	16	42.2823	-5.3839	-1.7604	42.4334	-6.0198	-2.1838	-0.1511	-0.6359	0.4234	0.7788	0.4234	Z
	17	43.1546	-1.0265	1.1458	43.3298	-1.1907	-0.3539	-0.1752	-0.1642	1.4997	1.5188	1.4997	Z
	18	43.4011	4.3910	1.1633	43.0824	3.9820	0.7508	0.3187	0.4090	0.4125	0.6626	0.4125	Z
	19	43.4373	9.7055	1.1746	43.3526	8.8623	2.6432	0.0847	0.8432	-1.4686	1.6956	-1.4686	Z
	20	43.1881	14.3877	1.2159	42.5886	12.3205	1.7322	0.5995	2.0672	-0.5163	2.2134	-0.5163	Z
	21	38.1382	-5.3520	-1.2724	38.2029	-5.4848	-1.7557	-0.0647	-0.1328	0.4833	0.5054	0.4833	Z
	22	38.9473	-0.7922	1.1662	39.0624	-1.0355	0.0727	-0.1151	-0.2433	1.0935	1.1261	1.0935	Z
	23	38.9988	4.4975	1.1711	39.1231	4.2603	0.2321	-0.1243	0.2372	0.9390	0.9764	0.9390	Z
	24	38.8943	9.7602	1.2030	38.9844	9.2299	1.8881	-0.0901	0.5303	-0.6851	0.8710	-0.6851	Z
	25	38.7191	14.6126	1.2114	38.3770	13.4329	2.5416	0.3421	1.1797	-1.3302	1.8106	-1.3302	Z
	26	33.8174	-5.2644	-1.0829	33.9023	-4.9135	-1.5729	-0.0849	0.3509	0.4900	0.6886	0.4900	Z
	27	33.5796	-0.6418	0.4159	33.7667	-0.7944	0.3810	-0.1871	-0.1526	0.0349	0.2439	0.0349	Z
	28	33.5924	4.6866	0.2078	33.8014	4.5469	0.2603	-0.2090	0.1397	-0.0525	0.2568	-0.0525	Z
	29	33.6946	10.0276	0.4444	33.9840	9.8737	0.6798	-0.2894	0.1539	-0.2354	0.4035	-0.2354	Z
	30	33.6502	14.5168	0.2873	33.8182	14.3861	1.4248	-0.1680	0.1307	-1.1375	1.1572	-1.1375	Z

^A Positive values denote deformation as inward toward the occupant compartment, negative values denote deformations outward away from the occupant compartment.
^B Crush calculations that use multiple directional components will disregard components that are negative and only include positive values where the component is deforming inward toward the occupant compartment.
^C Direction for Crush column denotes which directions are included in the crush calculations. If "NA" then no intrusion is recorded, and Crush will be 0.

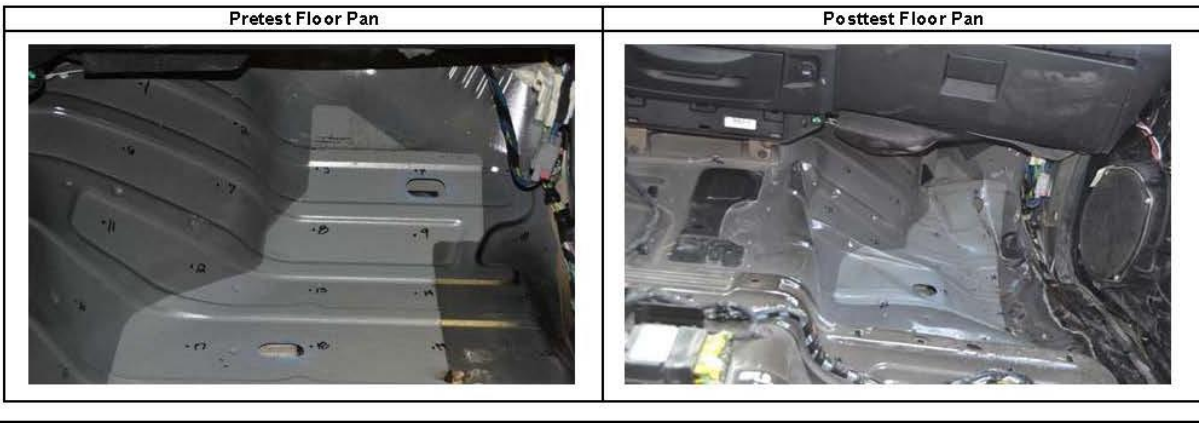

Figure C-4. Floor Pan Deformation Data – Set 2, Test No. H34BR-2

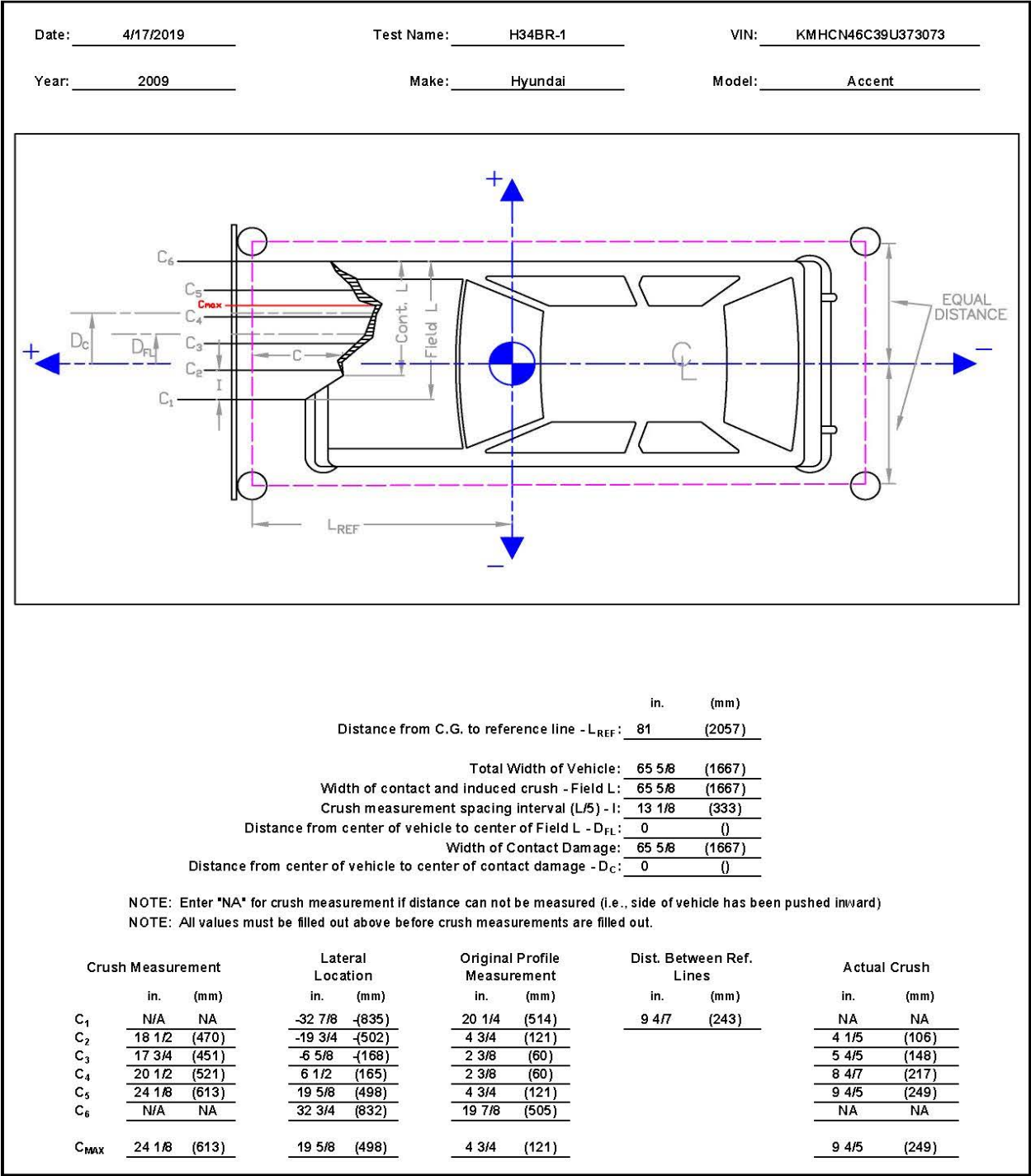
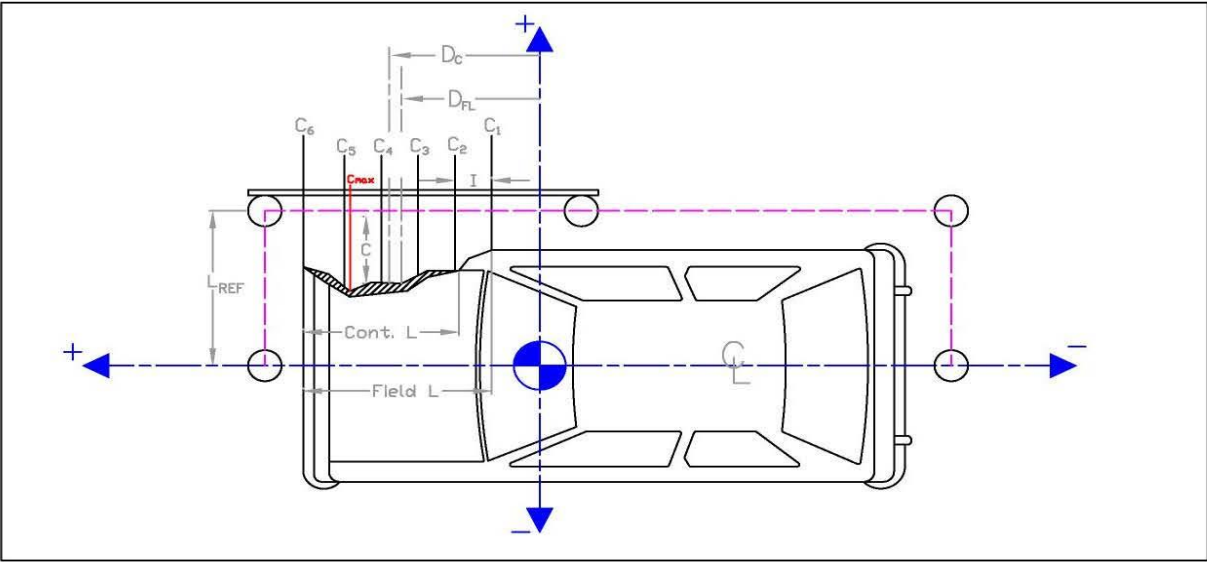

Figure C-5. Exterior Vehicle Crush (NASS) - Front, Test No. H34BR-1

Date: 4/17/2019 Test Name: H34BR-1 VIN: KMHCHN46C39U373073
Year: 2009 Make: Hyundai Model: Accent



Distance from centerline to reference line - L _{REF} :	in.	(mm)
	36	(914)
Total Vehicle Length:	168 1/8	(4270)
Distance from vehicle c.g. to 1/2 of Vehicle total length:	-11 5/8	(-295)
Width of contact and induced crush - Field L:	168 1/8	(4270)
Crush measurement spacing interval (L/5) - I:	33 5/8	(854)
Distance from vehicle c.g. to center of Field L - D _{FL} :	-11 5/8	(-295)
Width of Contact Damage:	168 1/8	(4270)
Distance from vehicle c.g. to center of contact damage - D _C :	-11 5/8	(-295)

NOTE: Enter "NA" for crush measurement if distance can not be measured (i.e., front of vehicle has been pushed inward or tire has been removed)
NOTE: All values must be filled out above before crush measurements are filled out.

	Crush Measurement		Longitudinal Location		Original Profile Measurement		Dist. Between Ref. Lines		Actual Crush	
	in.	(mm)	in.	(mm)	in.	(mm)	in.	(mm)	in.	(mm)
C ₁	N/A	NA	-95 3/4	(-2432)	14 3/4	(375)	0	()	NA	NA
C ₂	N/A	NA	-62 1/8	(-1578)	4	(102)			NA	NA
C ₃	5 3/4	(146)	-28 1/2	(-724)	3 3/8	(86)			2 3/8	(60)
C ₄	8	(203)	5 1/8	(130)	3 1/4	(83)			4 3/4	(121)
C ₅	N/A	NA	38 3/4	(984)	3 1/2	(89)			NA	NA
C ₆	N/A	NA	72 3/8	(1838)	36	(914)			NA	NA
C _{MAX}	24 1/4	(616)	48 1/2	(1232)	3 3/4	(95)			20 1/2	(521)

Figure C-6. Exterior Vehicle Crush (NASS) - Side, Test No. H34BR-1

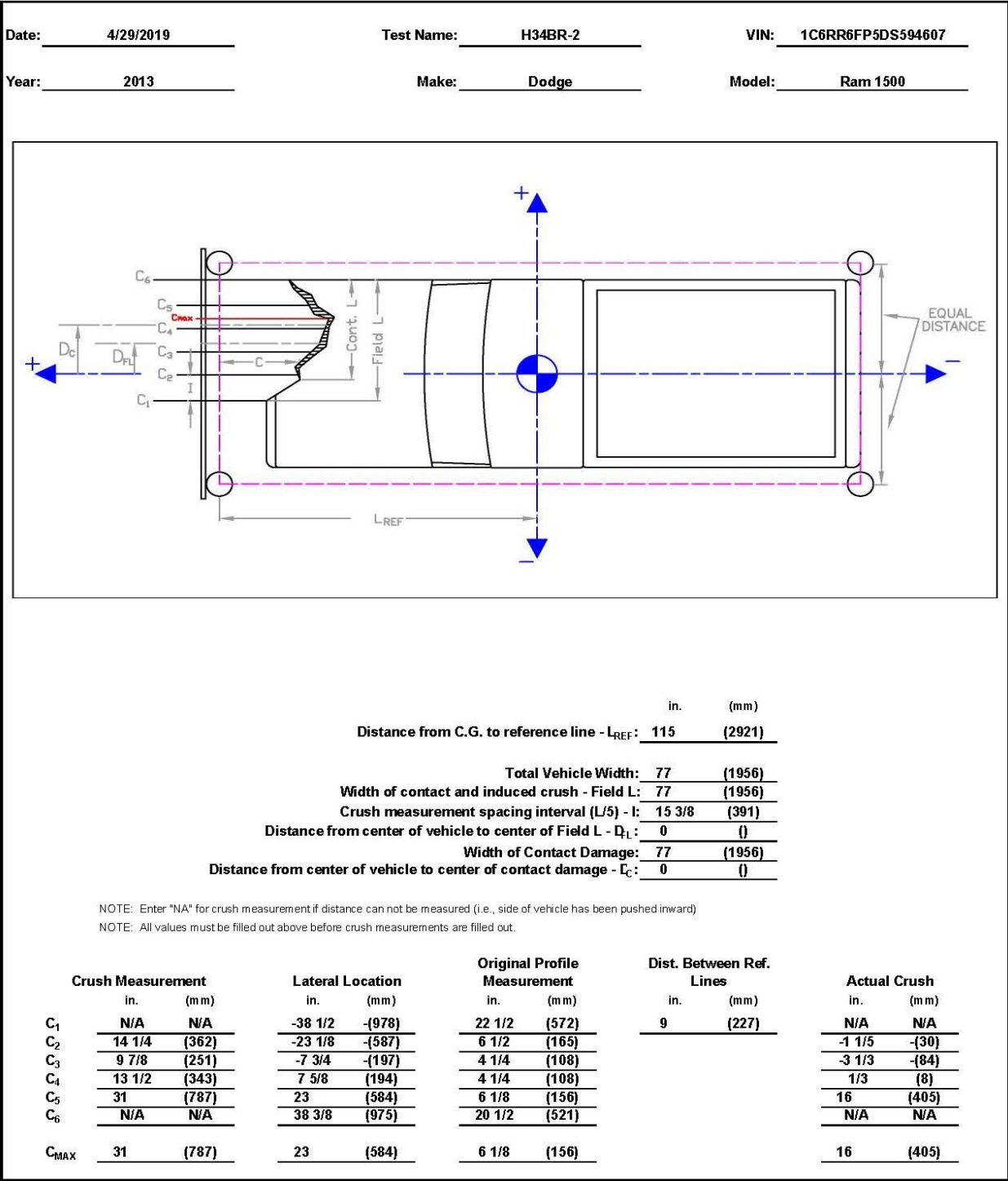
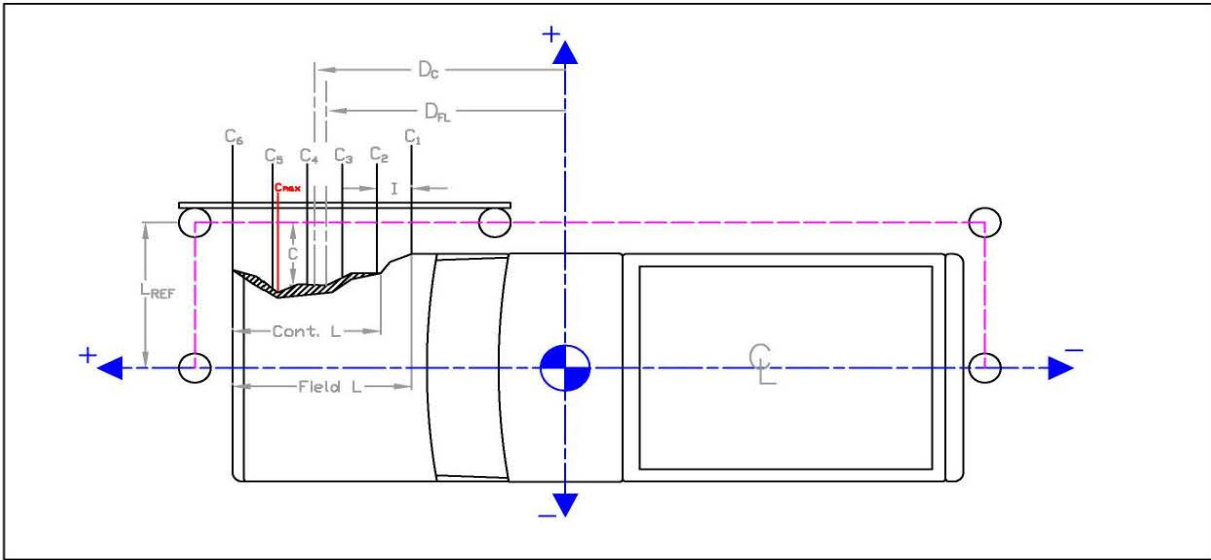

Figure C-7. Exterior Vehicle Crush (NASS) - Front, Test No. H34BR-2

Date: 4/29/2019 Test Name: H34BR-2 VIN: 1C6RR6FP5DS594607
Year: 2013 Make: Dodge Model: Ram 1500



Distance from centerline to reference line - L_{REF}: 44 in. (1118) mm
Total Vehicle Length: 229 1/4 (5823)
Distance from vehicle c.g. to 1/2 of Vehicle total length: -6 1/5 (-157)
Width of contact and induced crush - Field L: 229 1/4 (5823)
Crush measurement spacing interval (L/5) - I: 45 7/8 (1165)
Distance from vehicle c.g. to center of Field L - D_{FL}: -6 1/5 (-157)
Width of Contact Damage: 229 1/4 (5823)
Distance from vehicle c.g. to center of contact damage - D_C: -6 1/5 (-157)

NOTE: Enter "NA" for crush measurement if distance can not be measured (i.e., front of vehicle has been pushed inward or tire has been removed)
NOTE: All values must be filled out above before crush measurements are filled out.

Crush Measurement	Crush Measurement		Longitudinal Location		Original Profile Measurement		Dist. Between Ref. Lines		Actual	Crush
	in.	(mm)	in.	(mm)	in.	(mm)	in.	(mm)		
C ₁	7 5/8	(194)	-120 7/8	(-3070)	33 1/2	(851)	0	(0)	-25 7/8	(-657)
C ₂	N/A	N/A	-75	(-1905)	5 1/4	(133)			N/A	N/A
C ₃	5 1/4	(133)	-29 1/8	(-740)	5 5/8	(143)			- 3/8	(-10)
C ₄	5 1/4	(133)	16 3/4	(425)	5 1/8	(130)			1/8	(3)
C ₅	N/A	N/A	62 5/8	(1591)	5	(127)			N/A	N/A
C ₆	N/A	N/A	108 1/2	(2756)	33 1/2	(851)			N/A	N/A
C _{MAX}	25 1/4	(641)	87 1/4	(2216)	5 7/8	(149)			19 3/8	(492)

Exterior Vehicle Crush (NASS) - Side, Test No. H34BR-2

Appendix D. Accelerometer and Rate Transducer Data Plots, Test No. H34BR-1

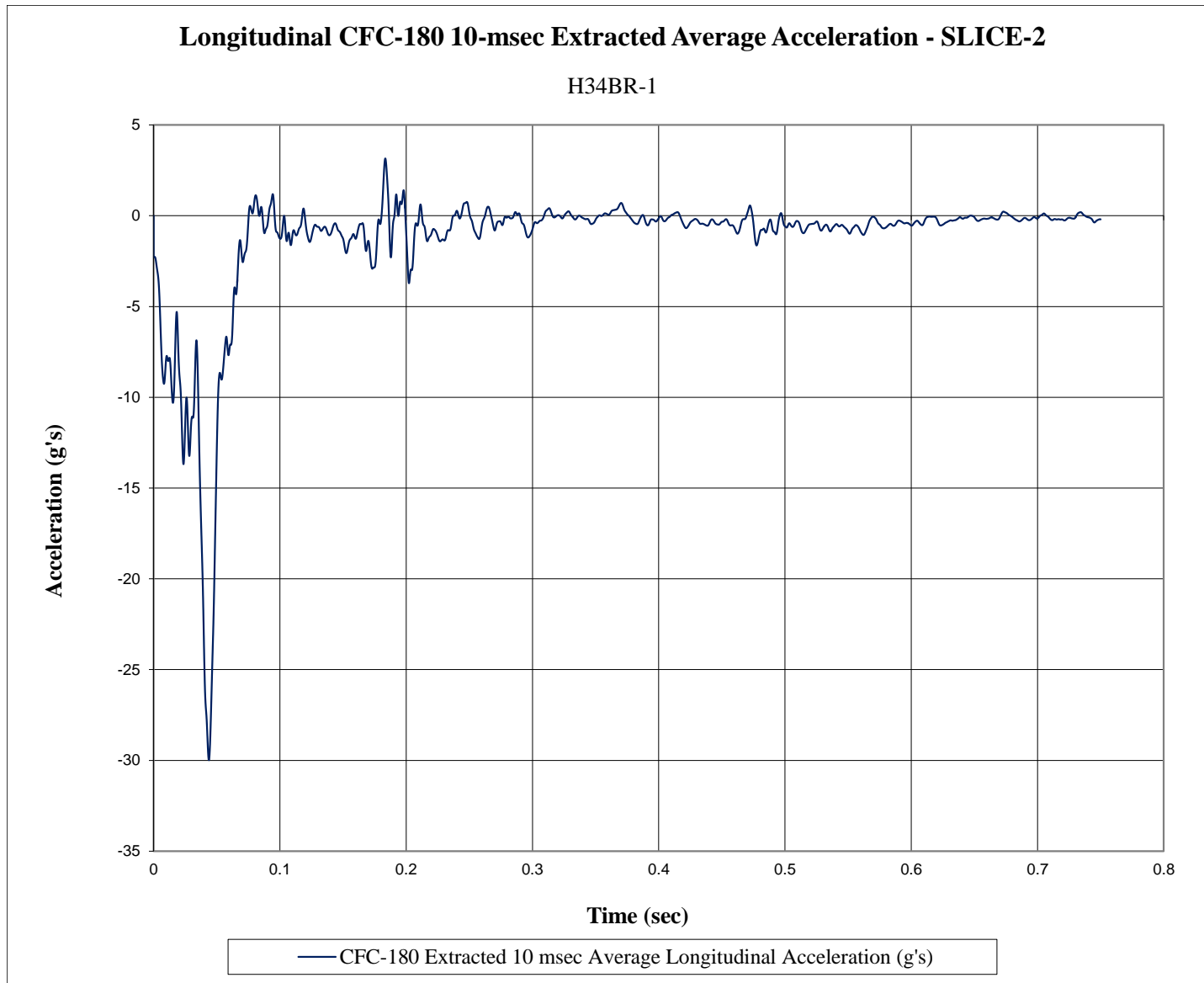

Figure D-1. 10-ms Average Longitudinal Deceleration (SLICE-2), Test No. H34BR-1

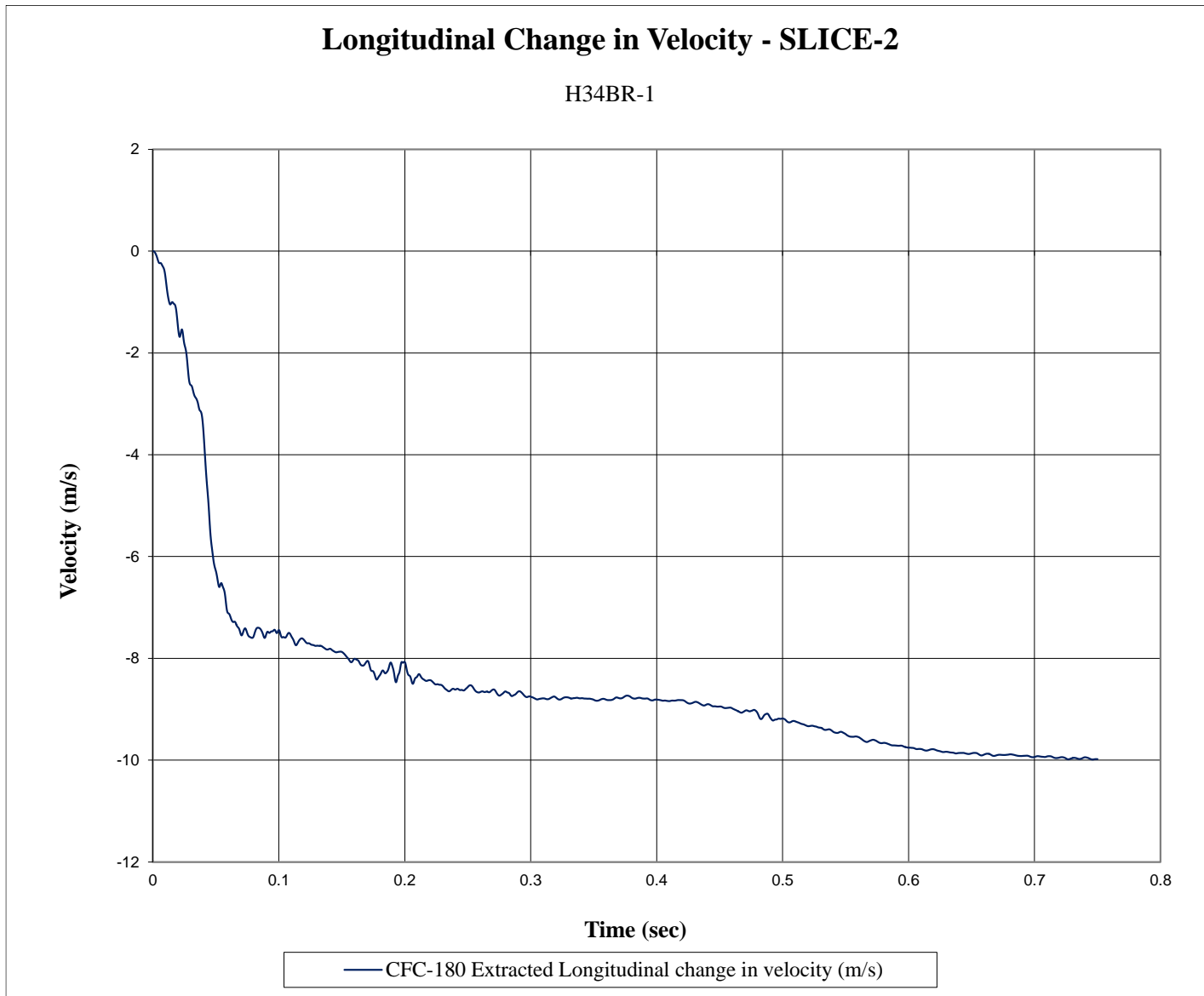

Figure D-2. Longitudinal Occupant Impact Velocity (SLICE-2), Test No. H34BR-1

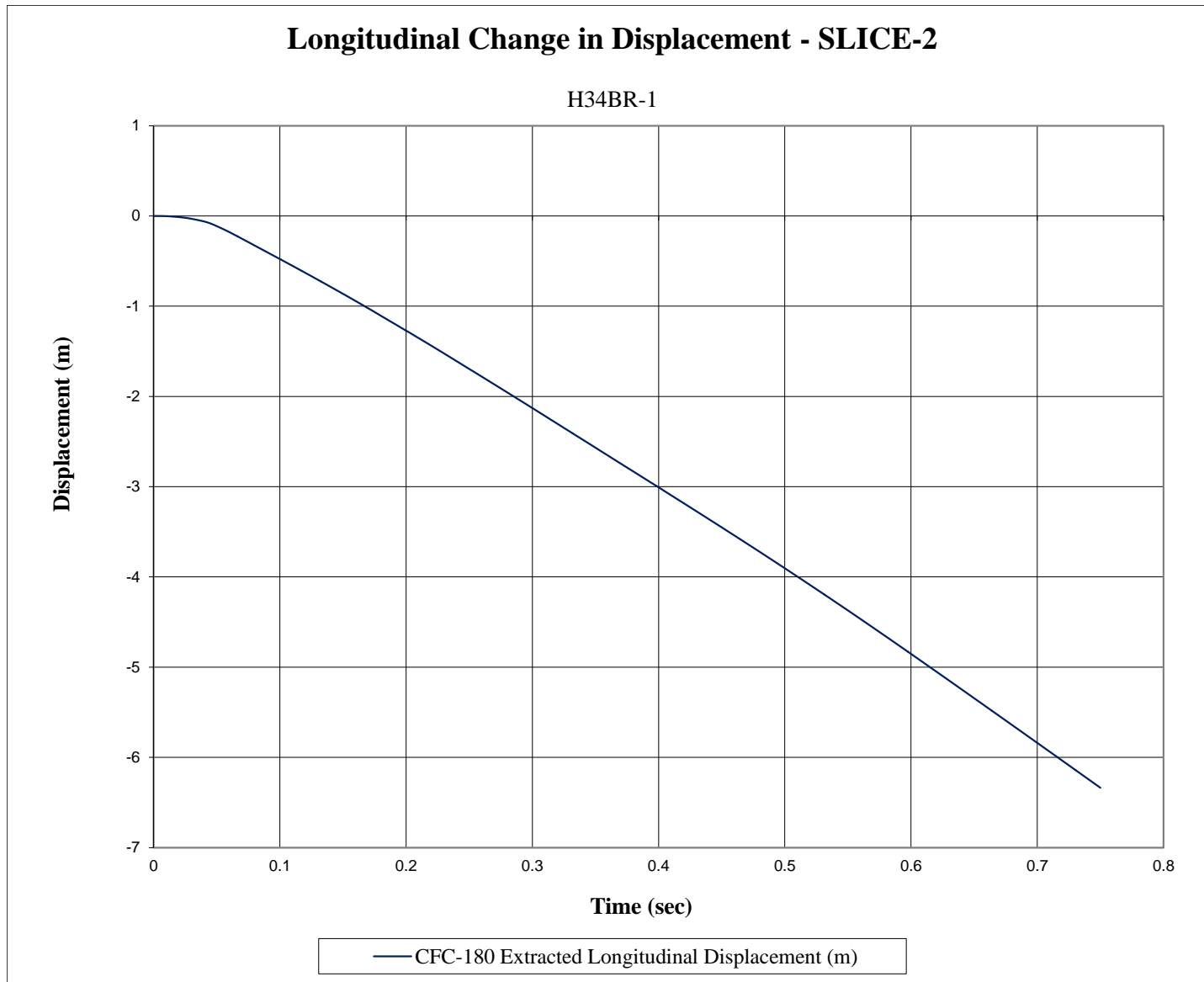

Figure D-3. Longitudinal Occupant Displacement (SLICE-2), Test No. H34BR-1

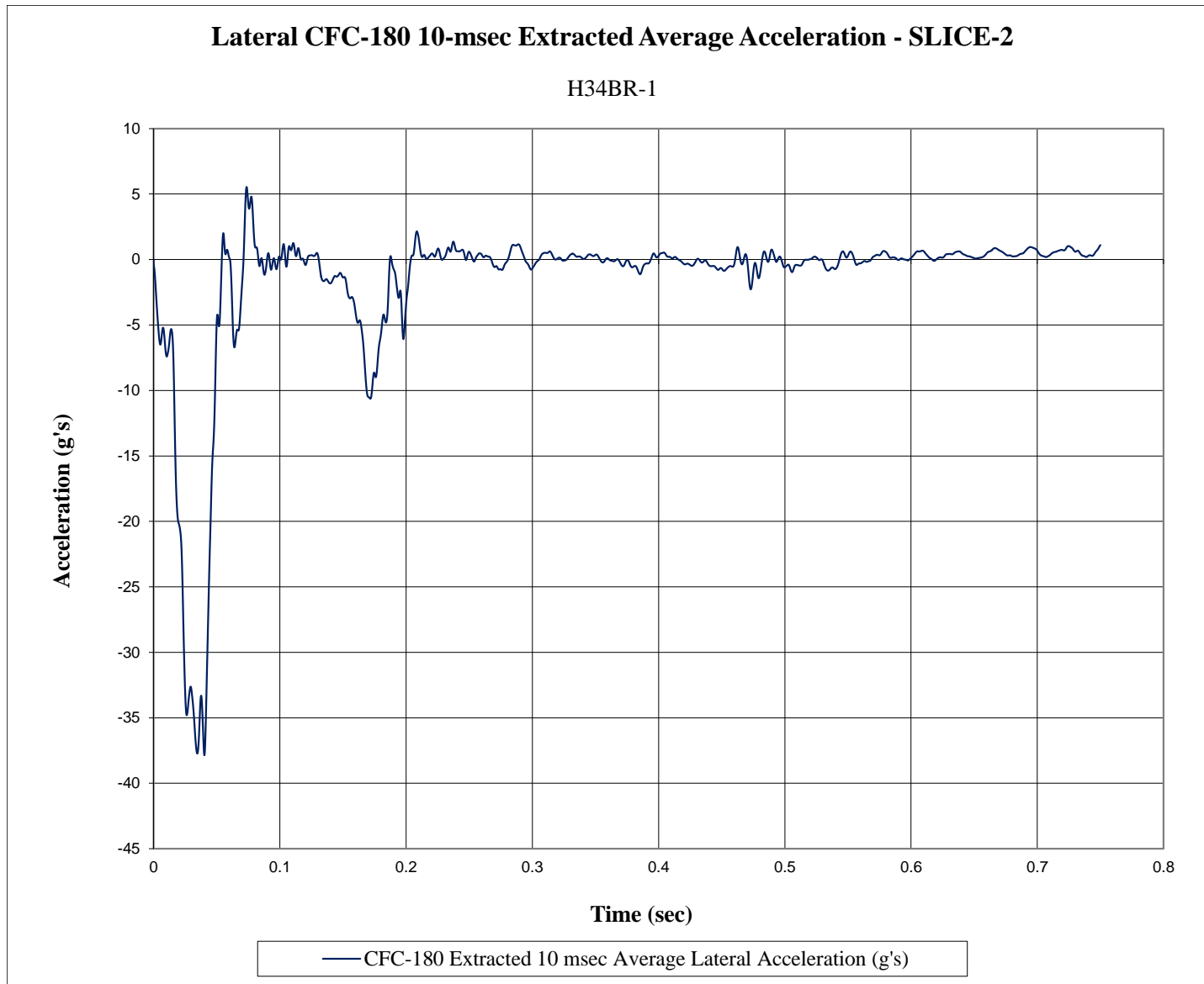

Figure D-4. 10-ms Average Lateral Deceleration (SLICE-2), Test No. H34BR-1

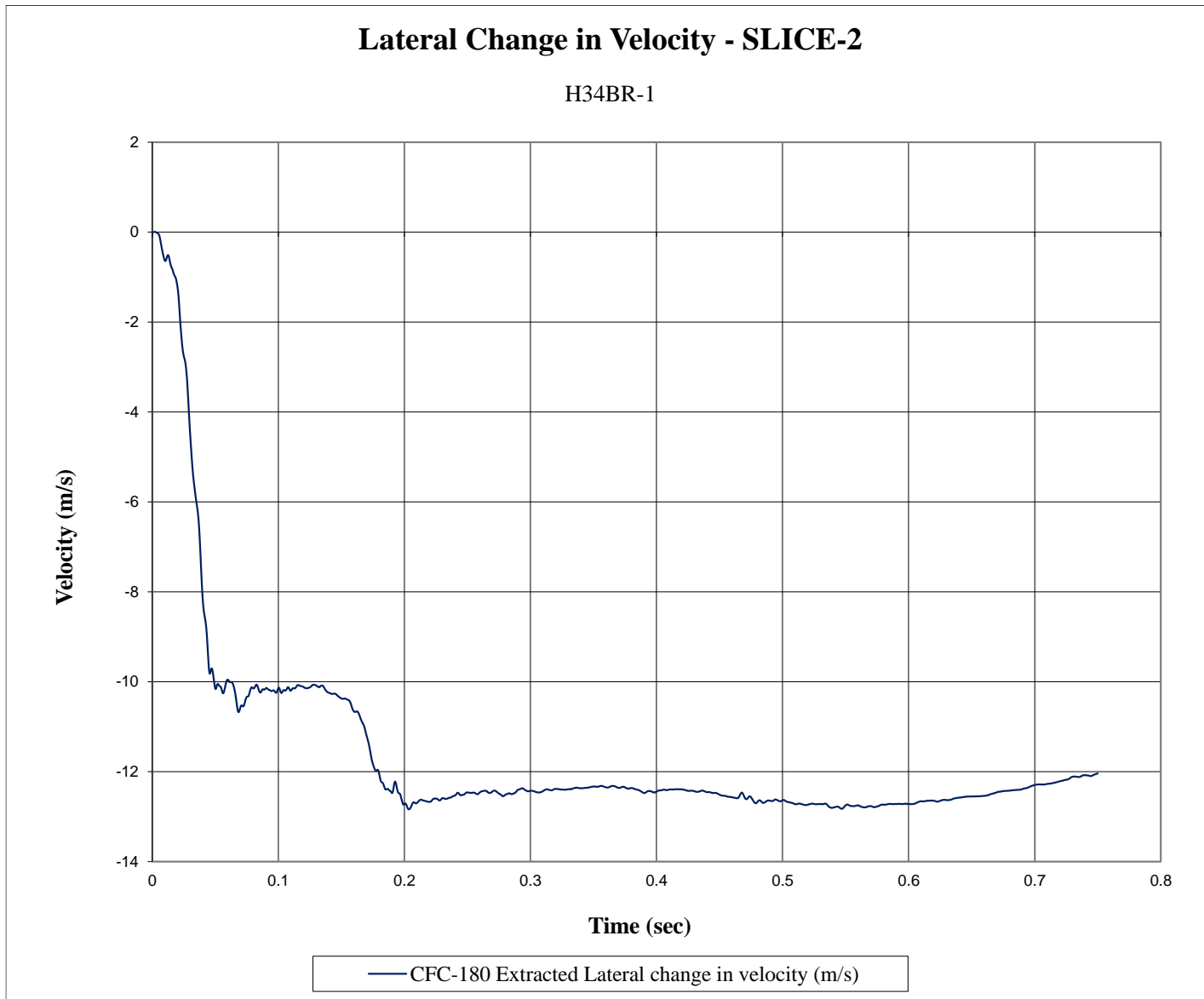

Figure D-5. Lateral Occupant Impact Velocity (SLICE-2), Test No. H34BR-1

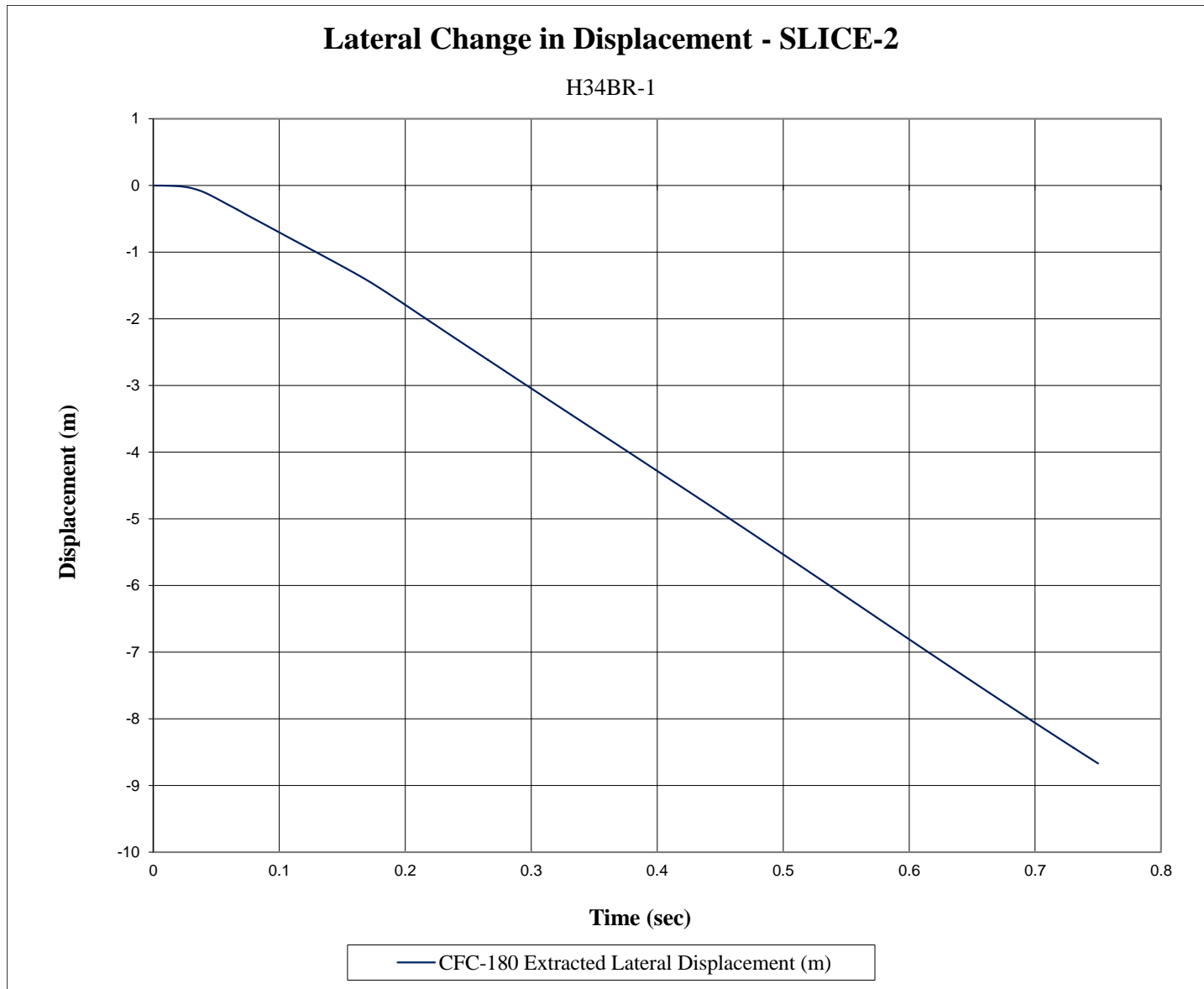

Figure D-6. Lateral Occupant Displacement (SLICE-2), Test No. H34BR-1

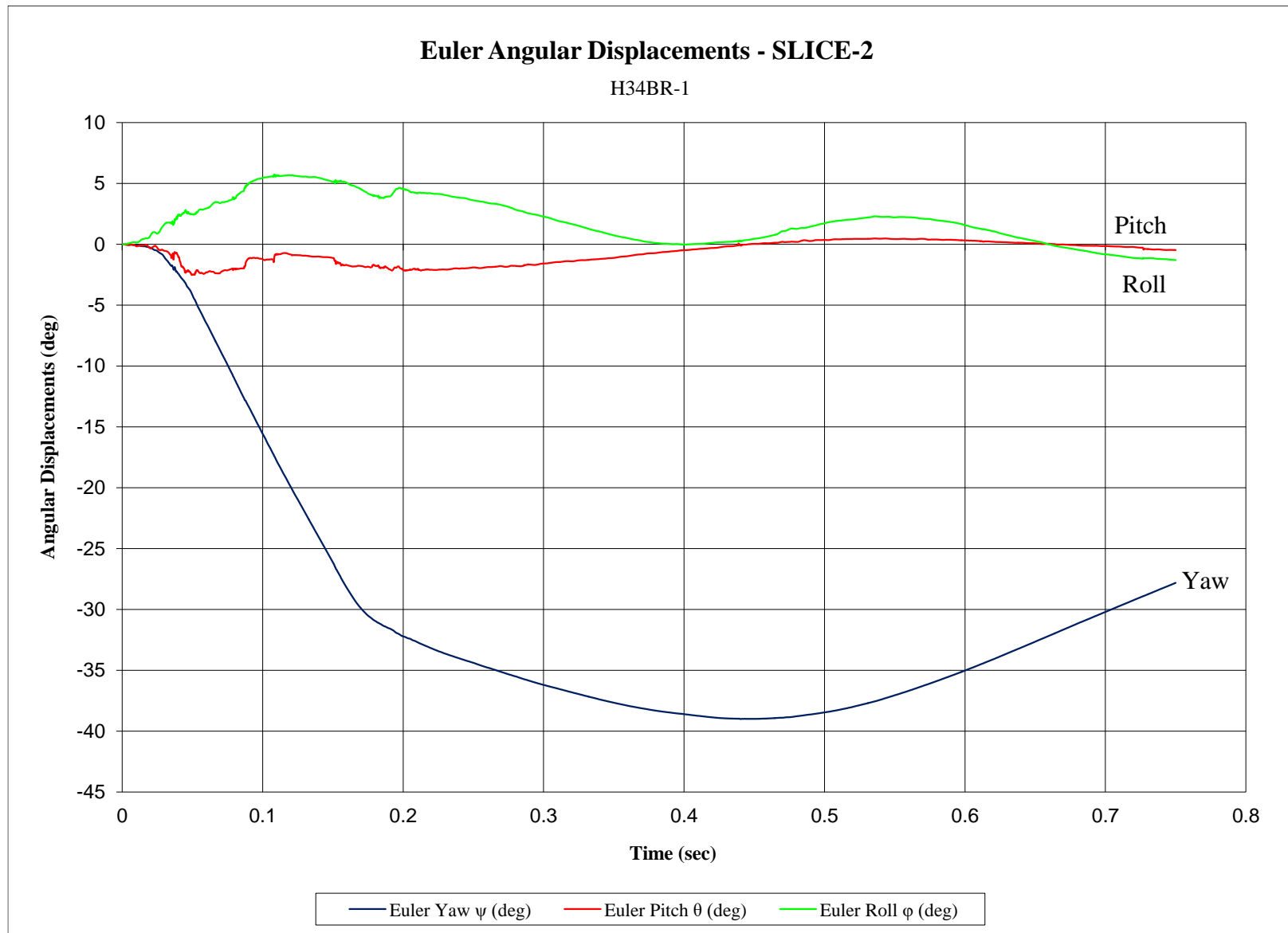

Figure D-7. Vehicle Angular Displacements (SLICE-2), Test No. H34BR-1

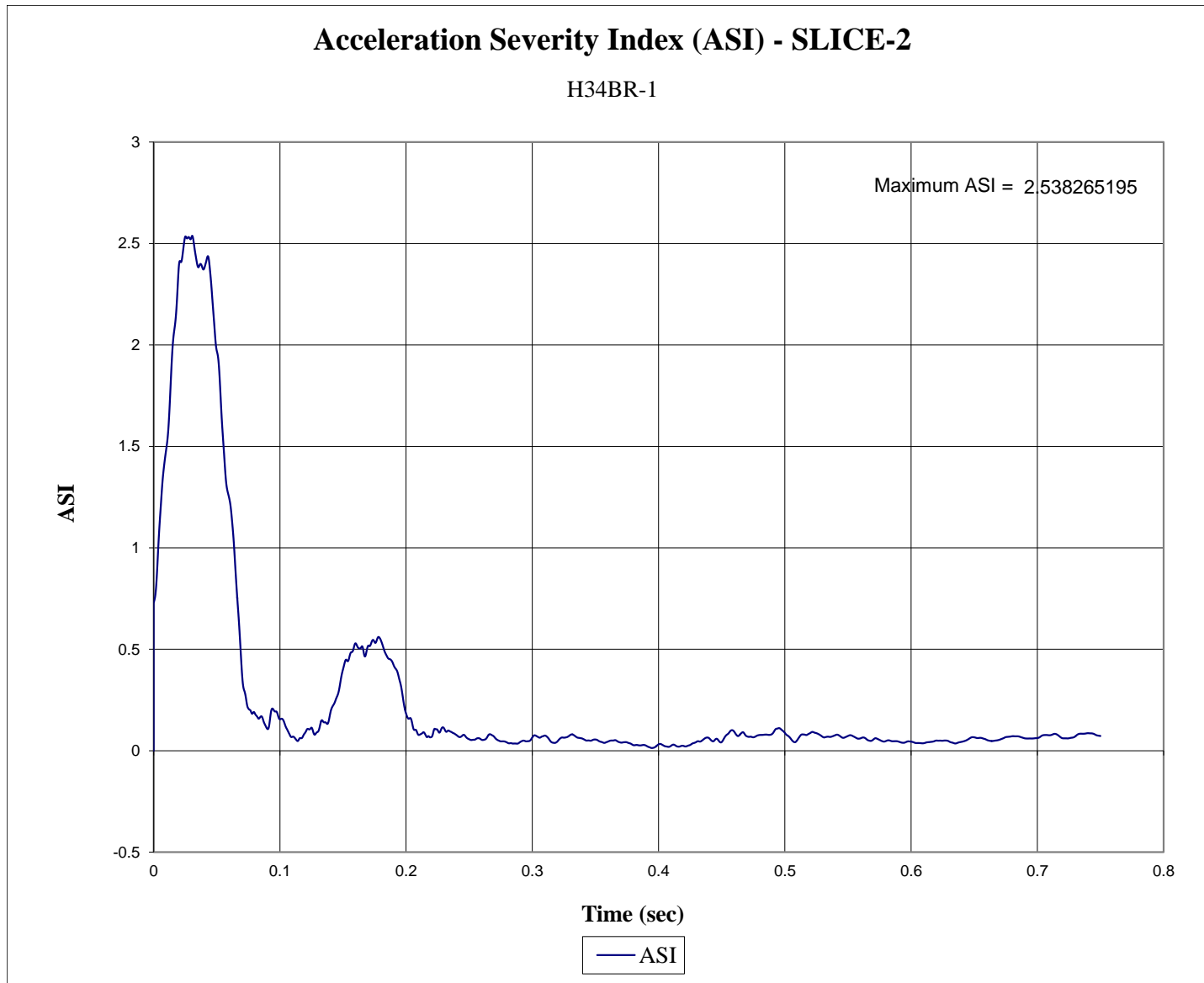

Figure D-8. Acceleration Severity Index (SLICE-2), Test No. H34BR-1

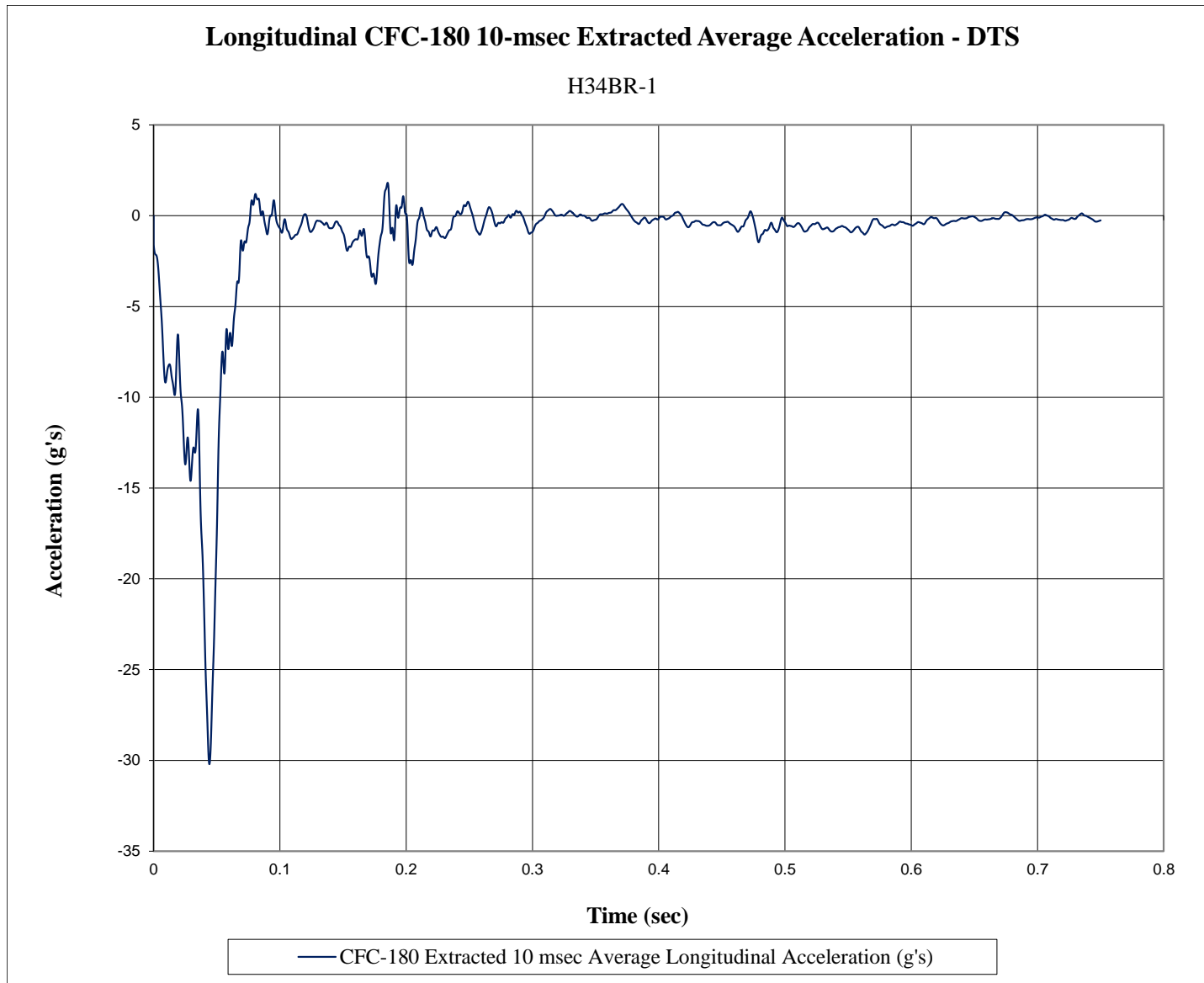

Figure D-9. 10-ms Average Longitudinal Deceleration (DTS), Test No. H34BR-1

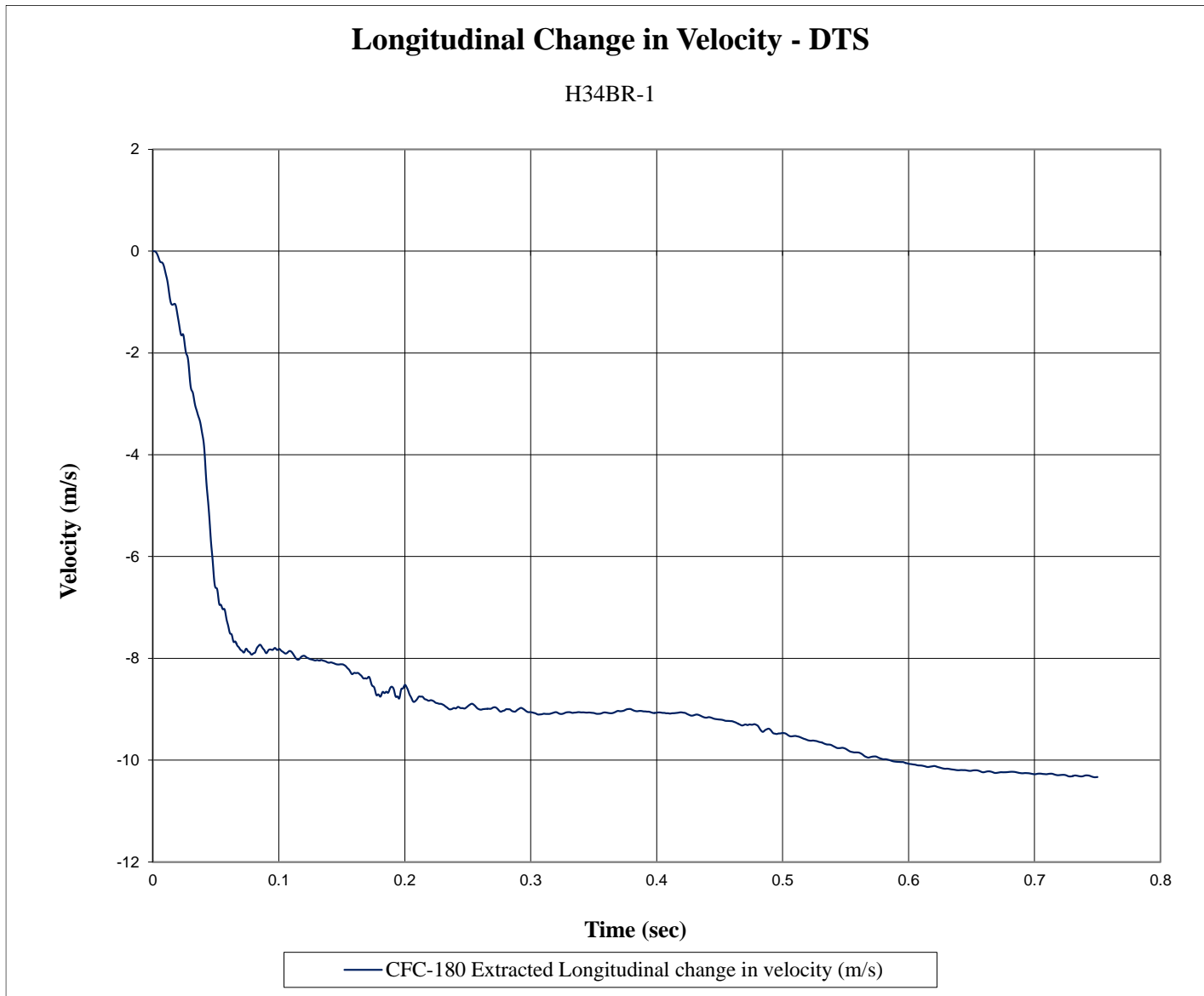

Figure D-10. Longitudinal Occupant Impact Velocity (DTS), Test No. H34BR-1

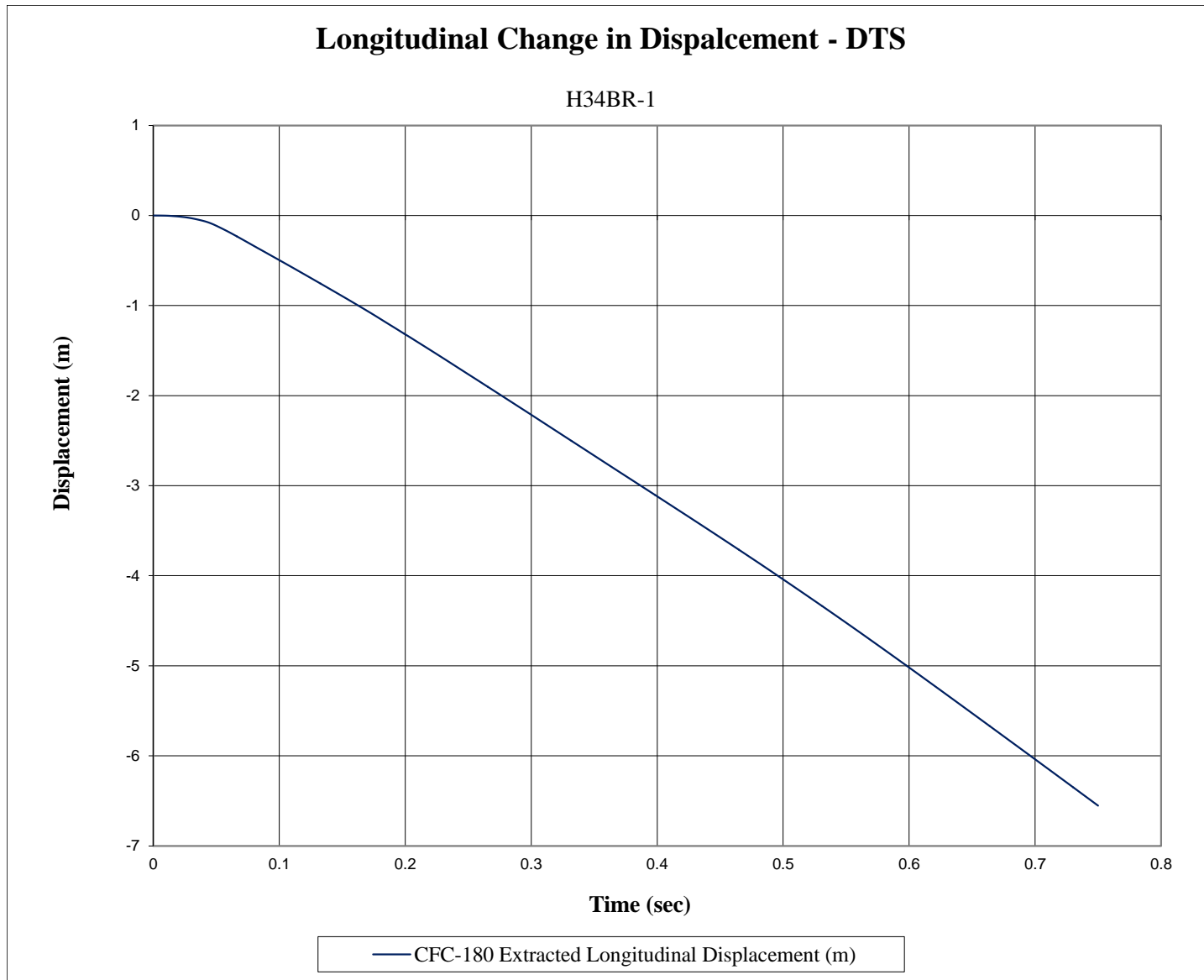

Figure D-11. Longitudinal Occupant Displacement (DTS), Test No. H34BR-1

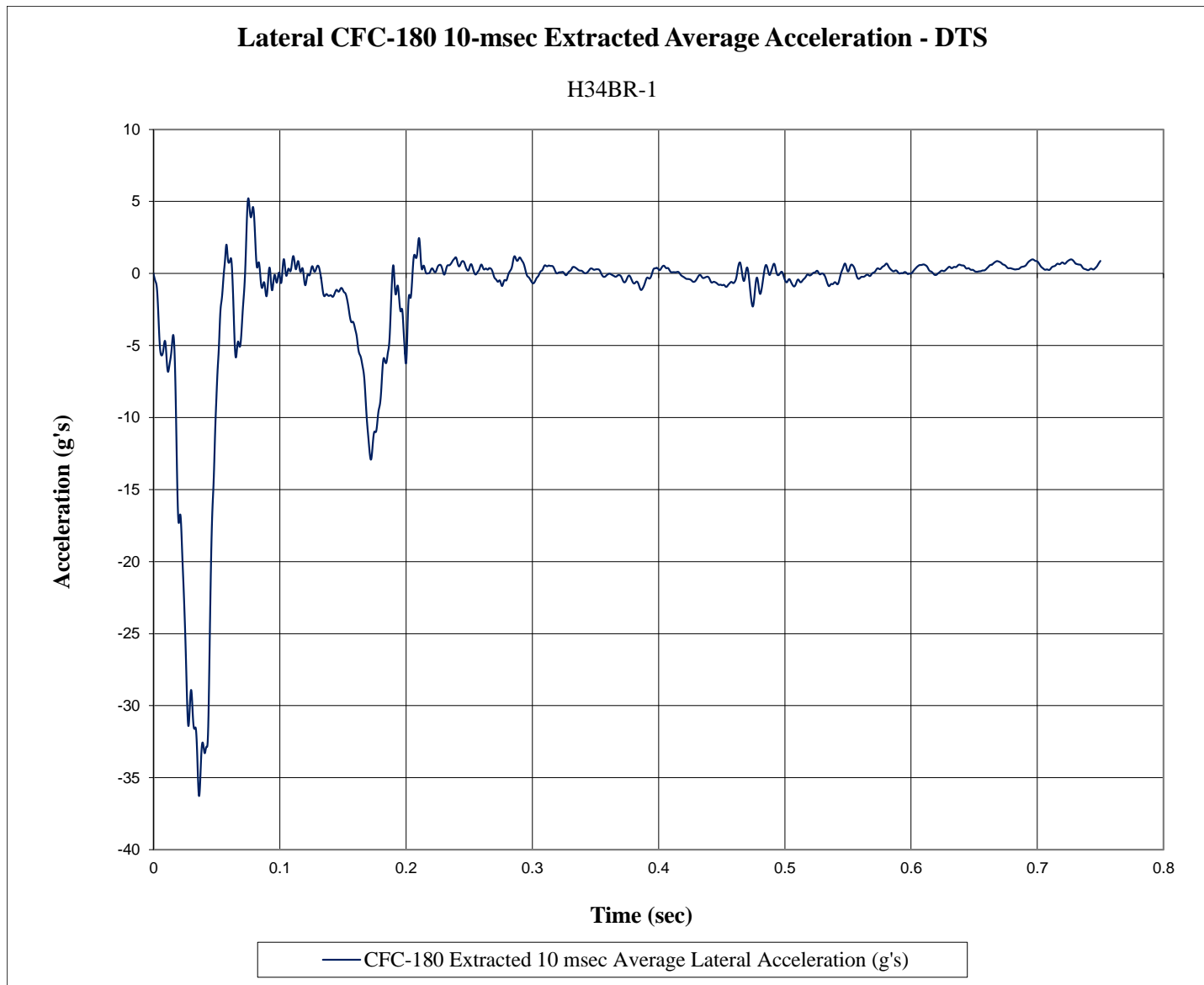

Figure D-12. 10-ms Average Lateral Deceleration (DTS), Test No. H34BR-1

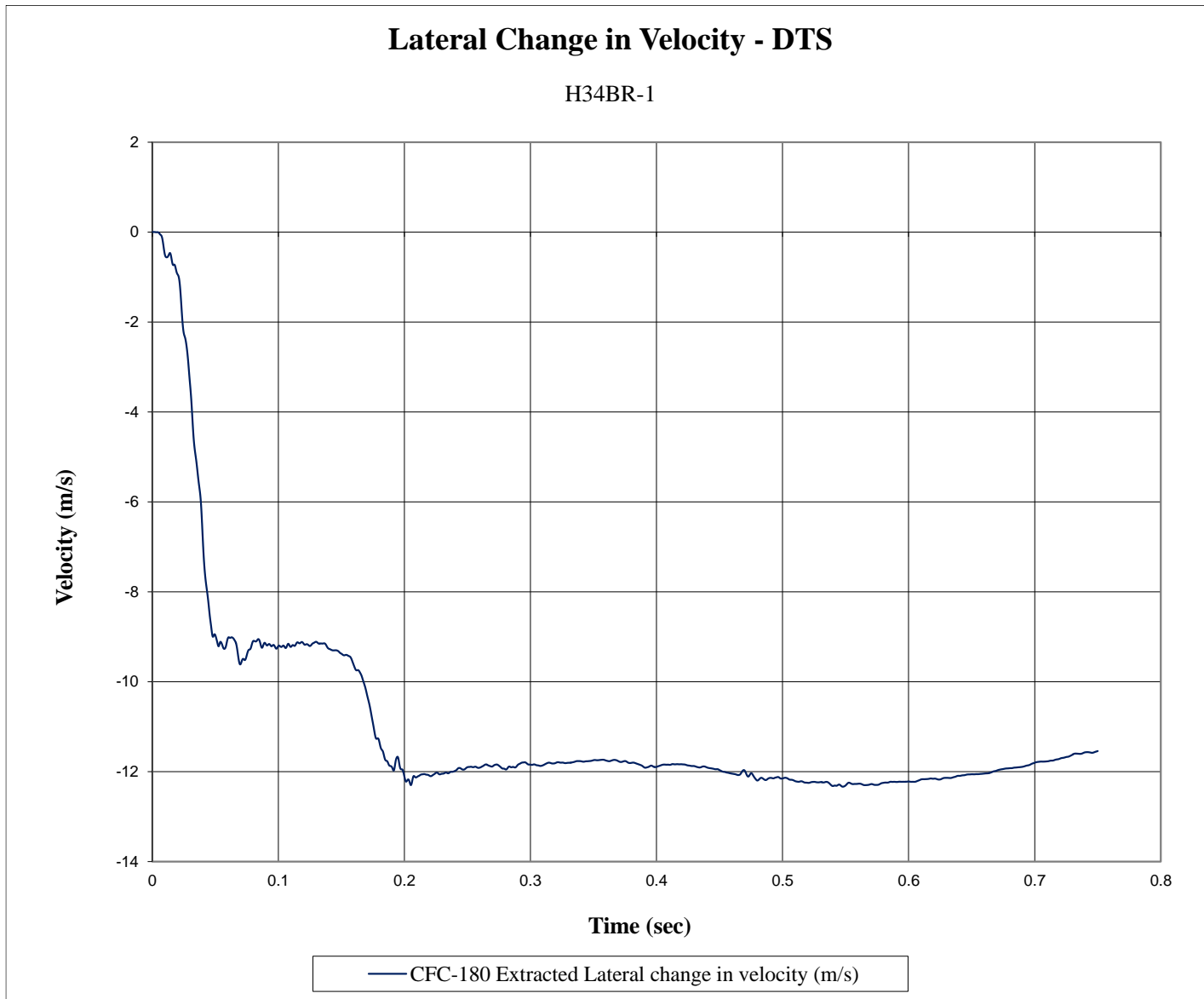

Figure D-13. Lateral Occupant Impact Velocity (DTS), Test No. H34BR-1

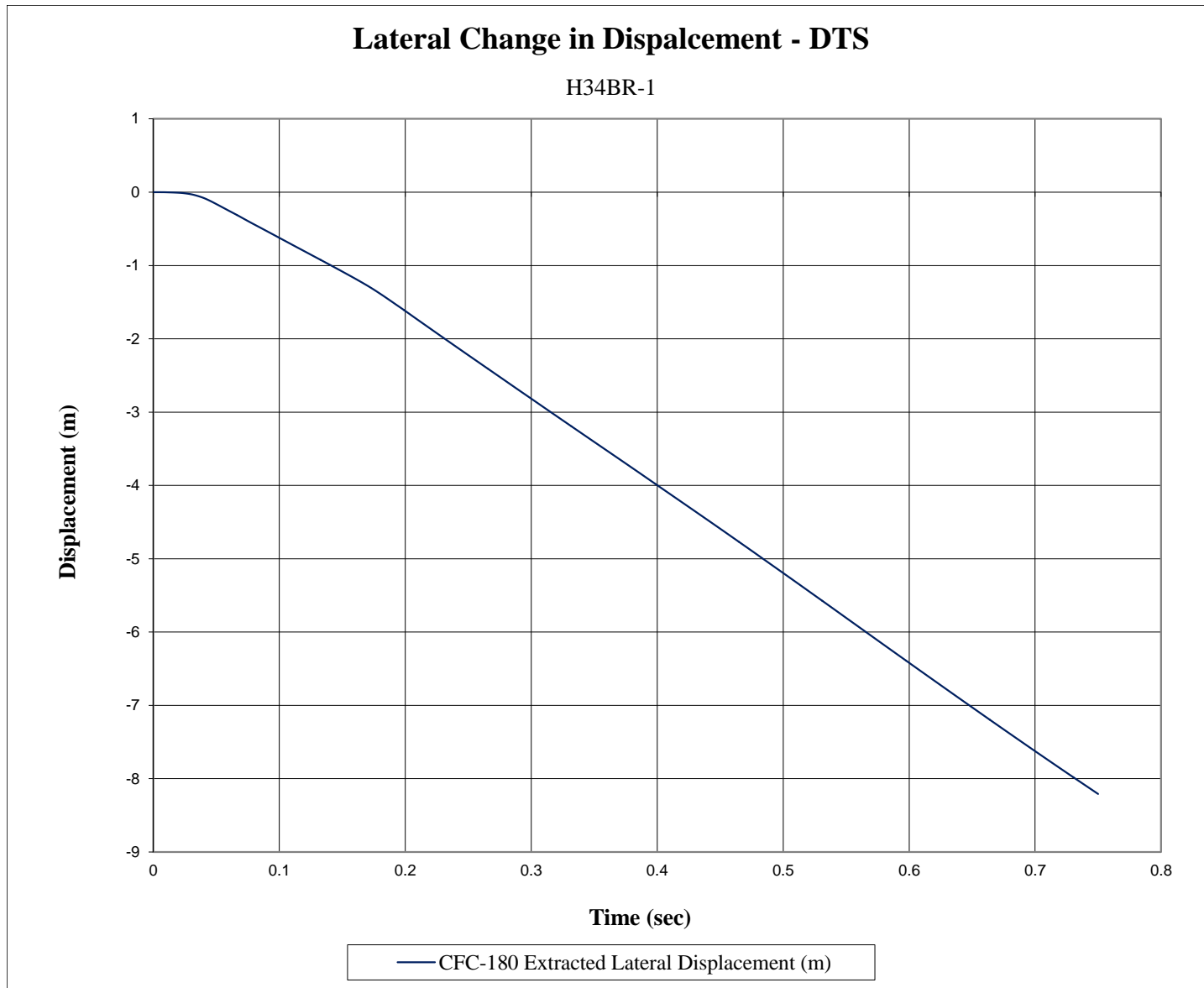

Figure D-14. Lateral Occupant Displacement (DTS), Test No. H34BR-1

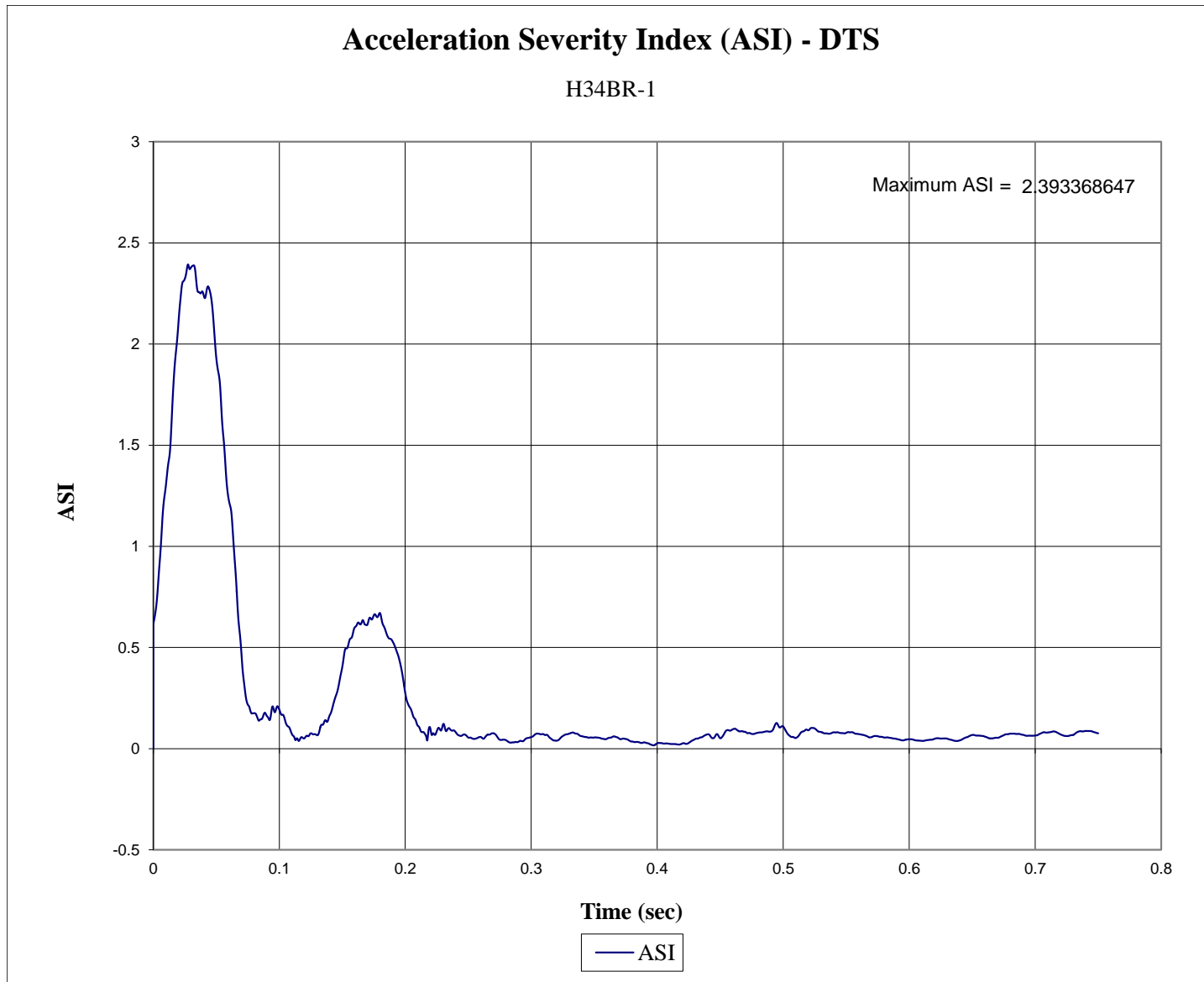

Figure D-15. Acceleration Severity Index (DTS), Test No. H34BR-1

Appendix E. Accelerometer and Rate Transducer Data Plots, Test No. H34BR-2

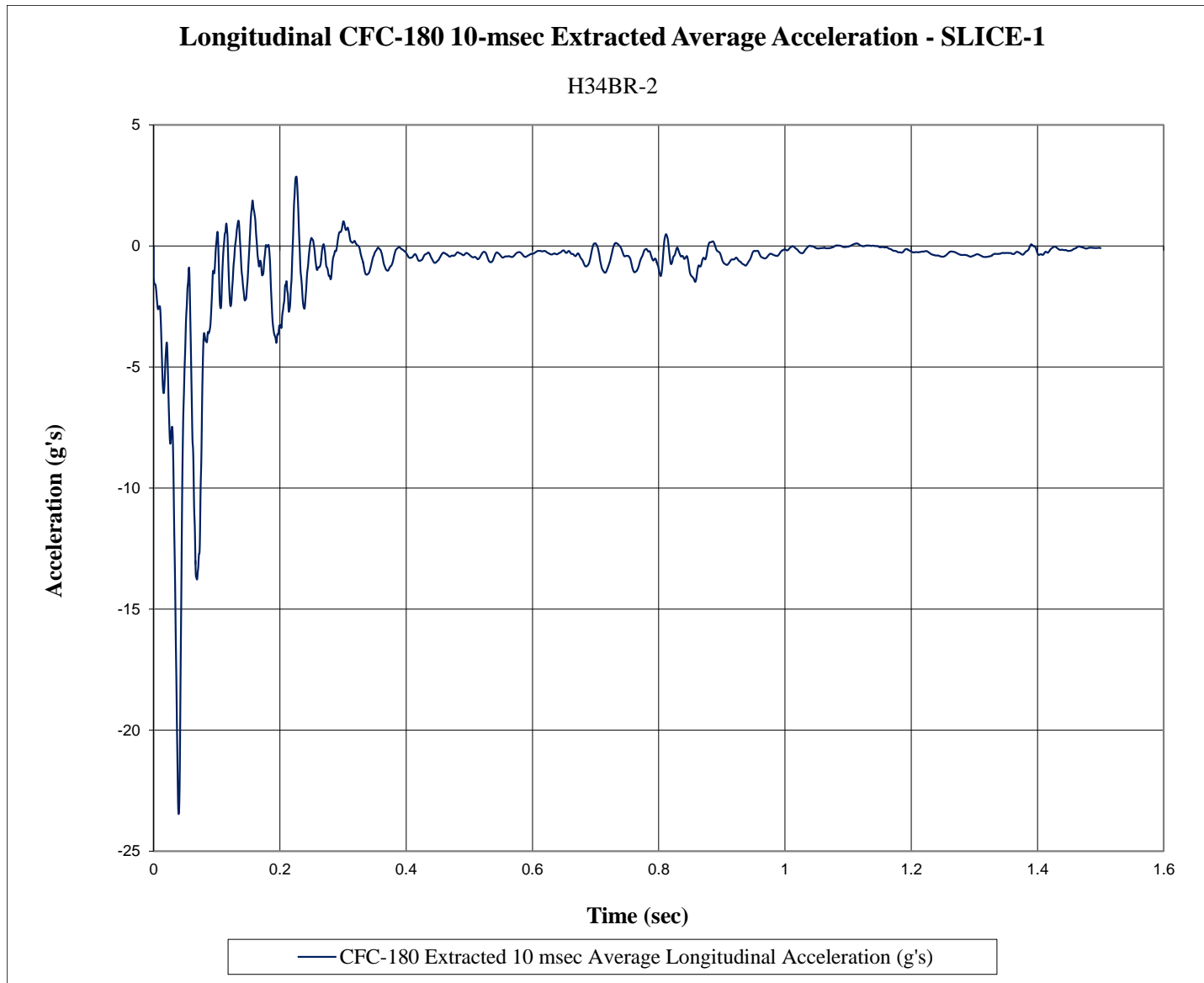

Figure E-1. 10-ms Average Longitudinal Deceleration (SLICE-1), Test No. H34BR-2

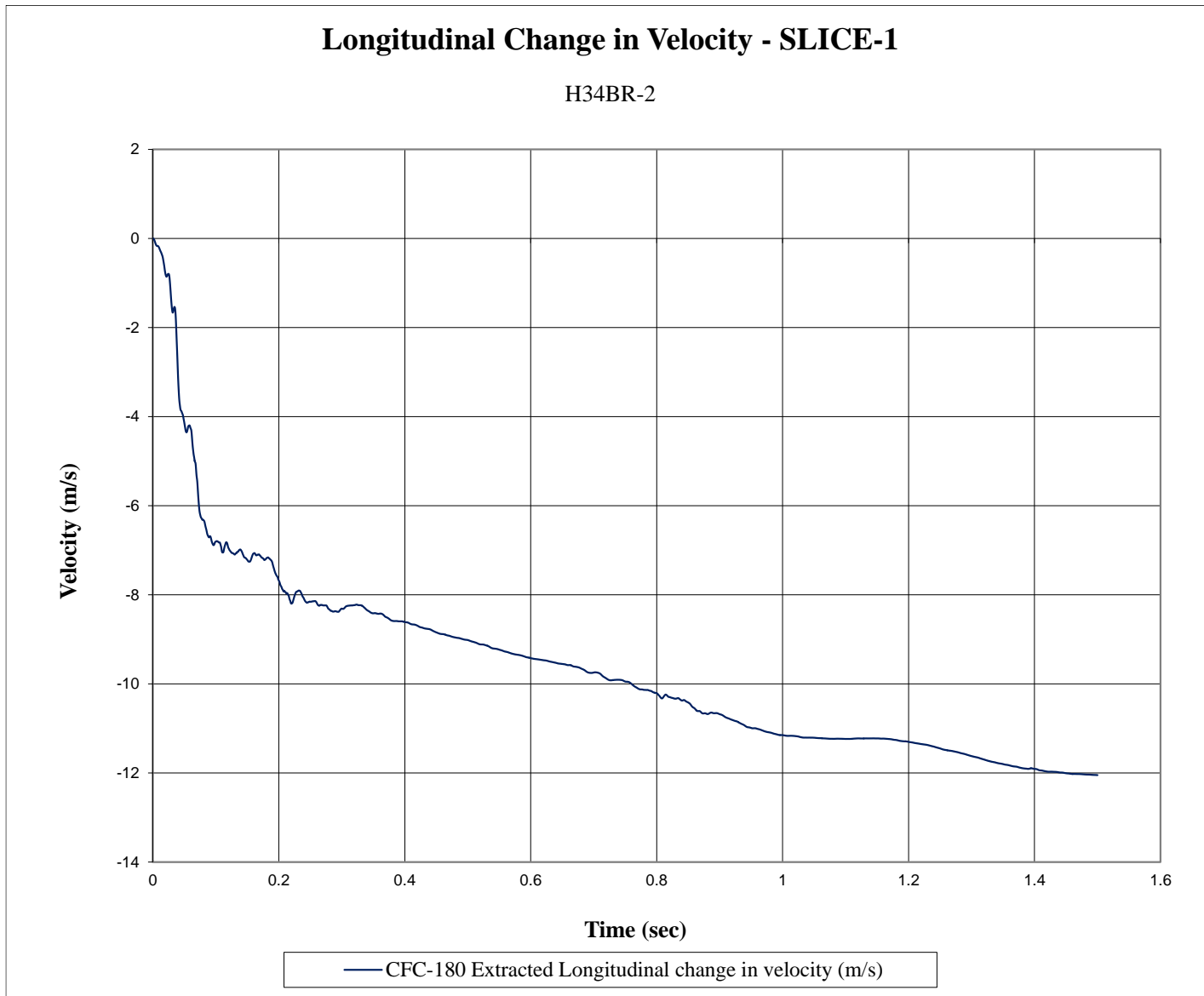

Figure E-2. Longitudinal Occupant Impact Velocity (SLICE-1), Test No. H34BR-2

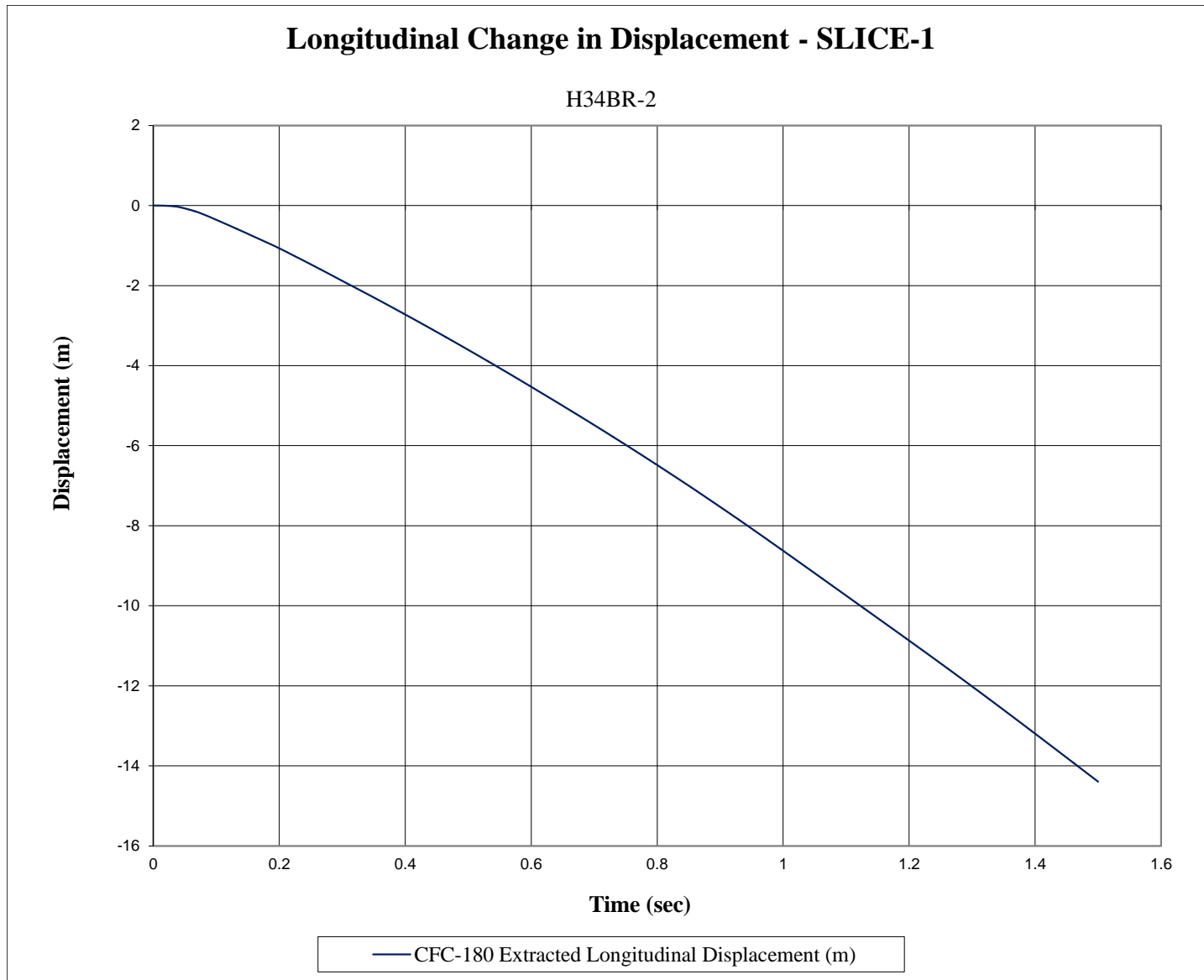

Figure E-3. Longitudinal Occupant Displacement (SLICE-1), Test No. H34BR-2

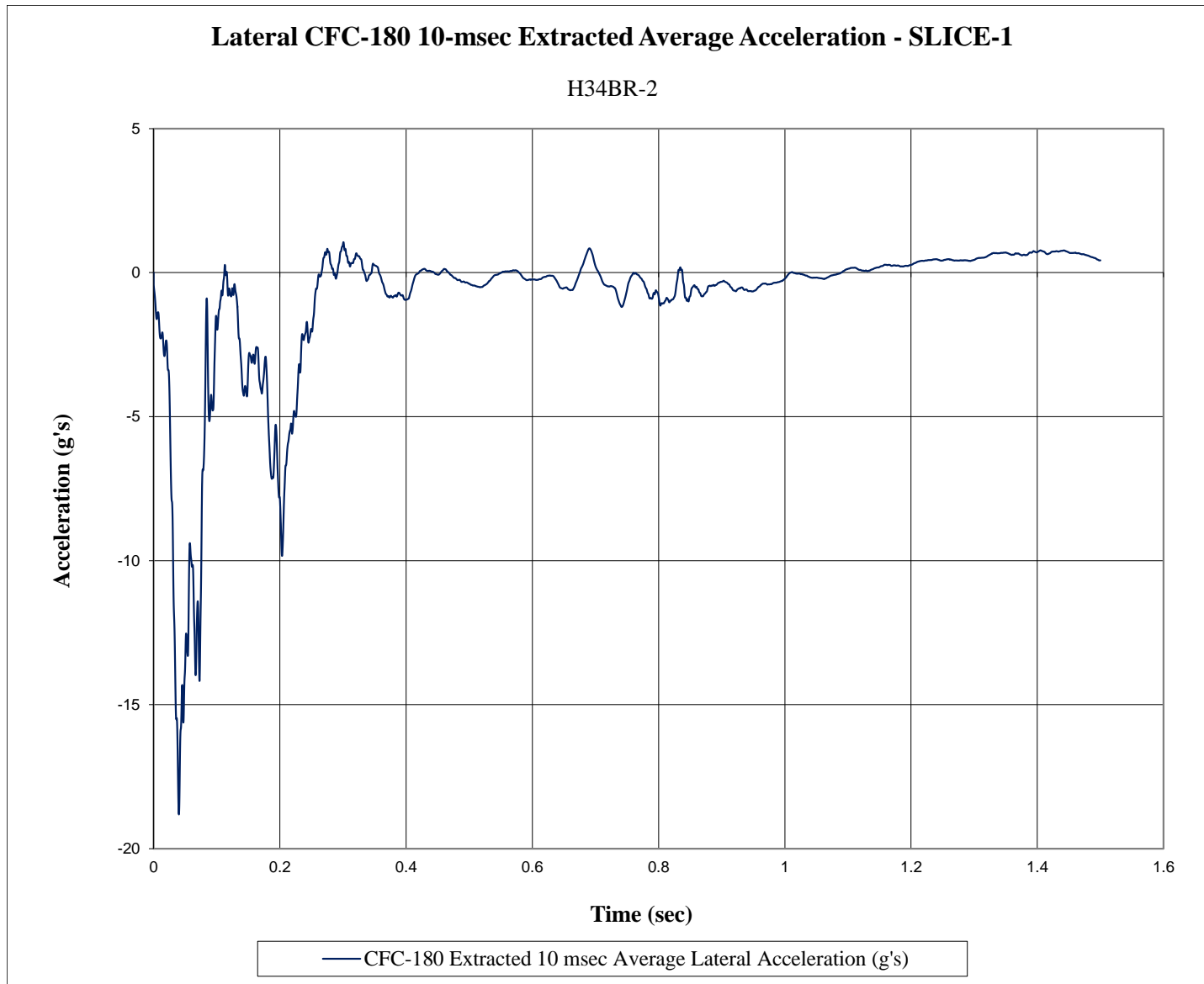

Figure E-4. 10-ms Average Lateral Deceleration (SLICE-1), Test No. H34BR-2

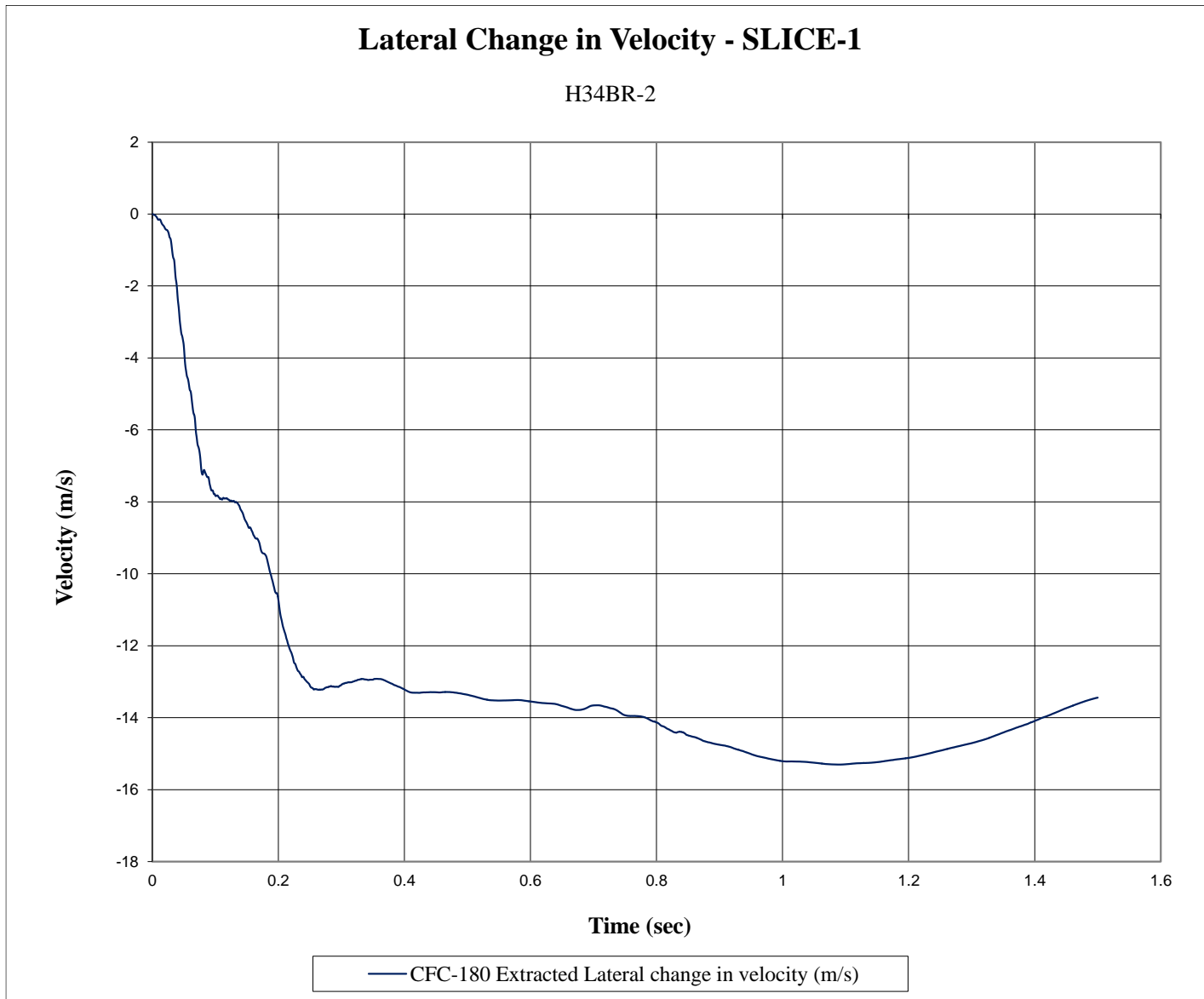

Figure E-5. Lateral Occupant Impact Velocity (SLICE-1), Test No. H34BR-2

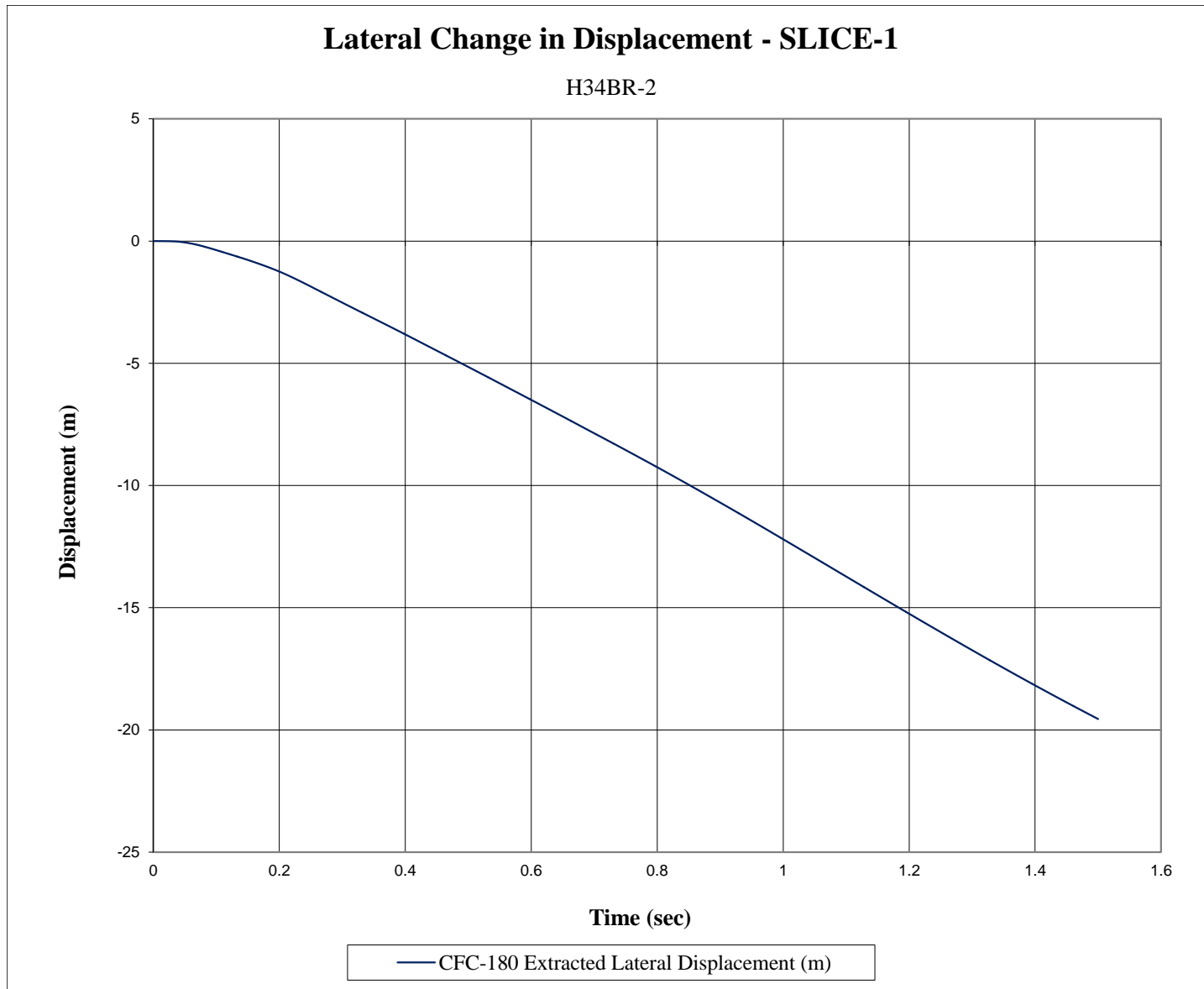

Figure E-6. Lateral Occupant Displacement (SLICE-1), Test No. H34BR-2

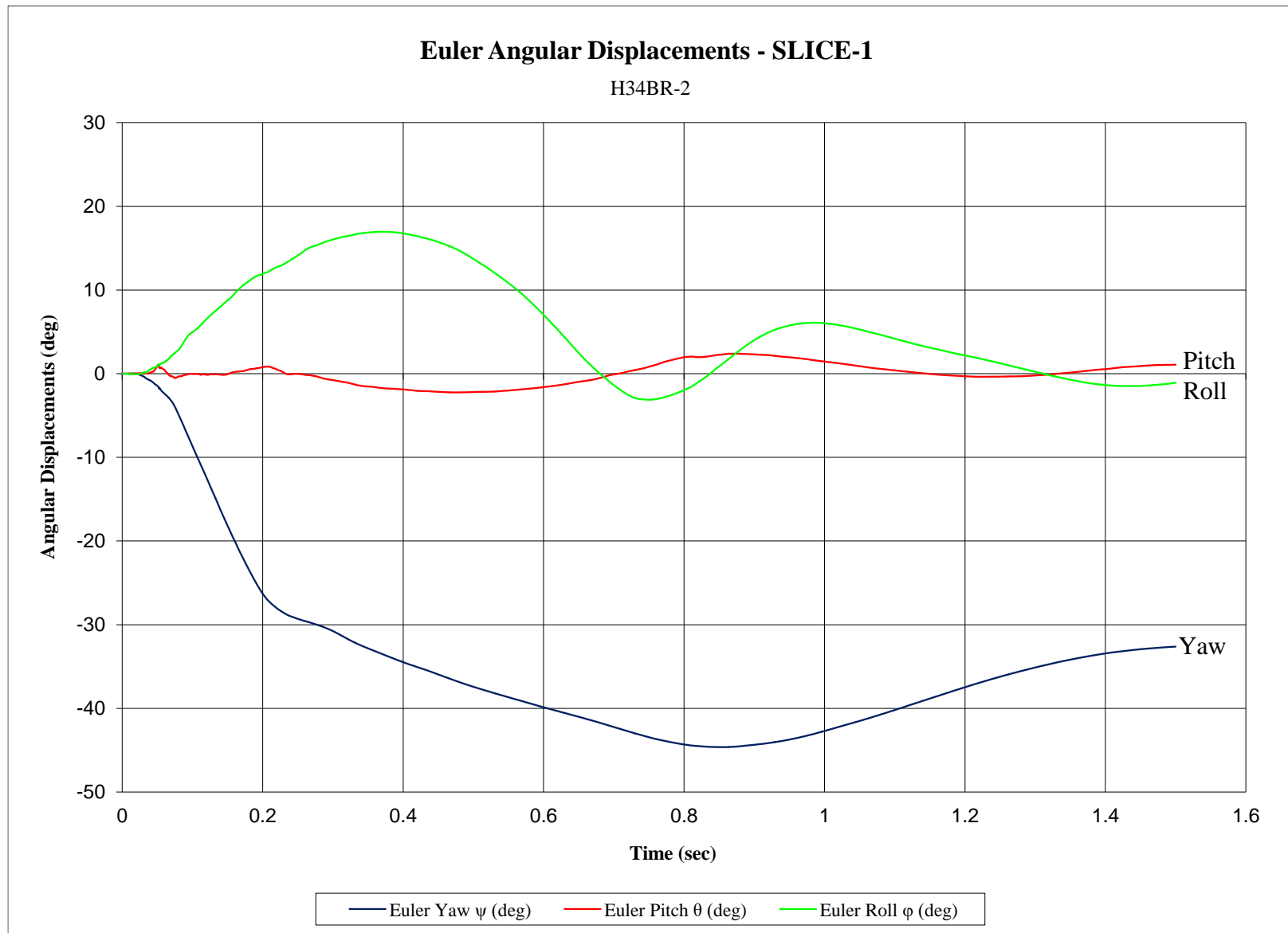

Figure E-7. Vehicle Angular Displacements (SLICE-1), Test No. H34BR-2

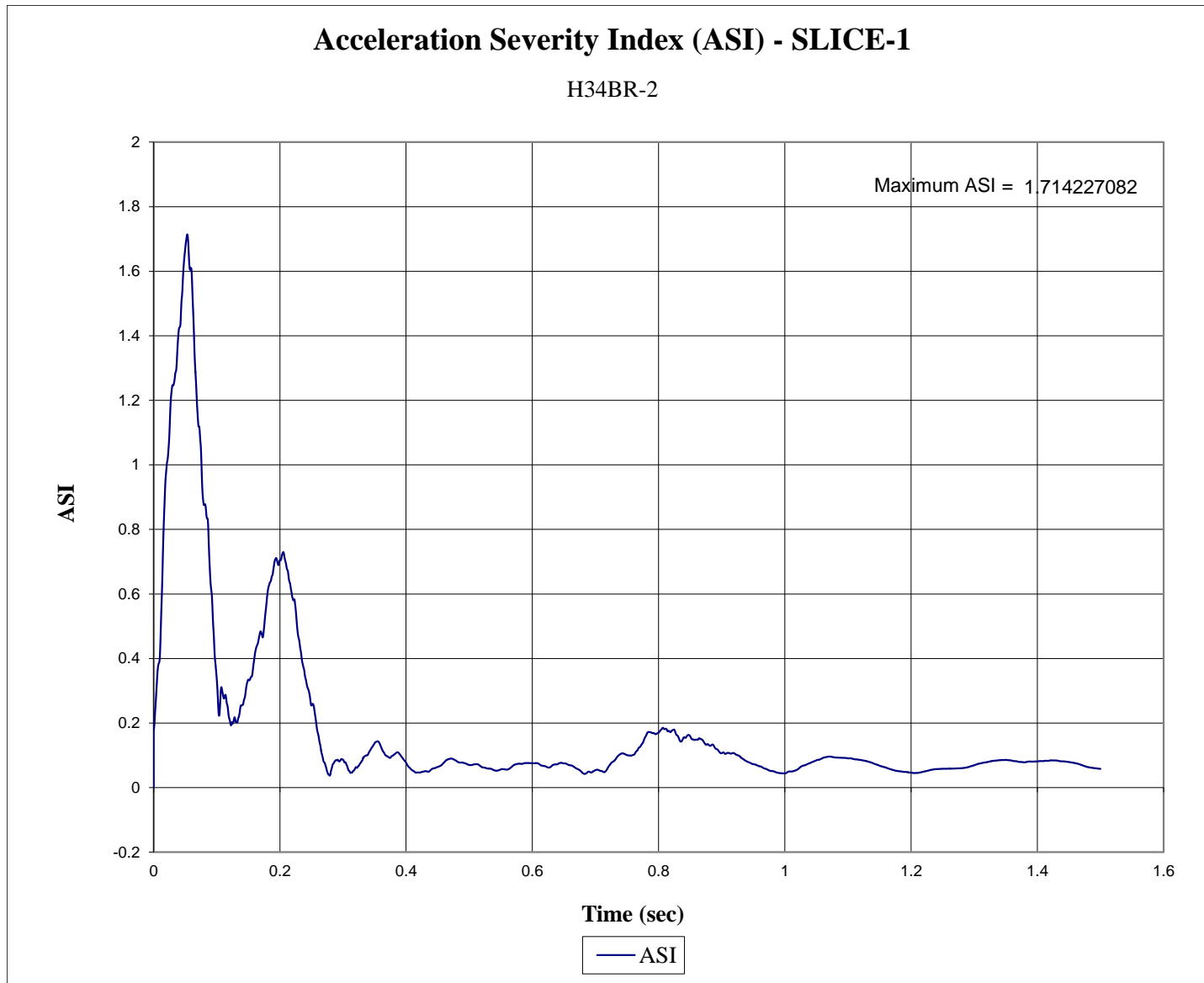

Figure E-8. Acceleration Severity Index (SLICE-1), Test No. H34BR-2

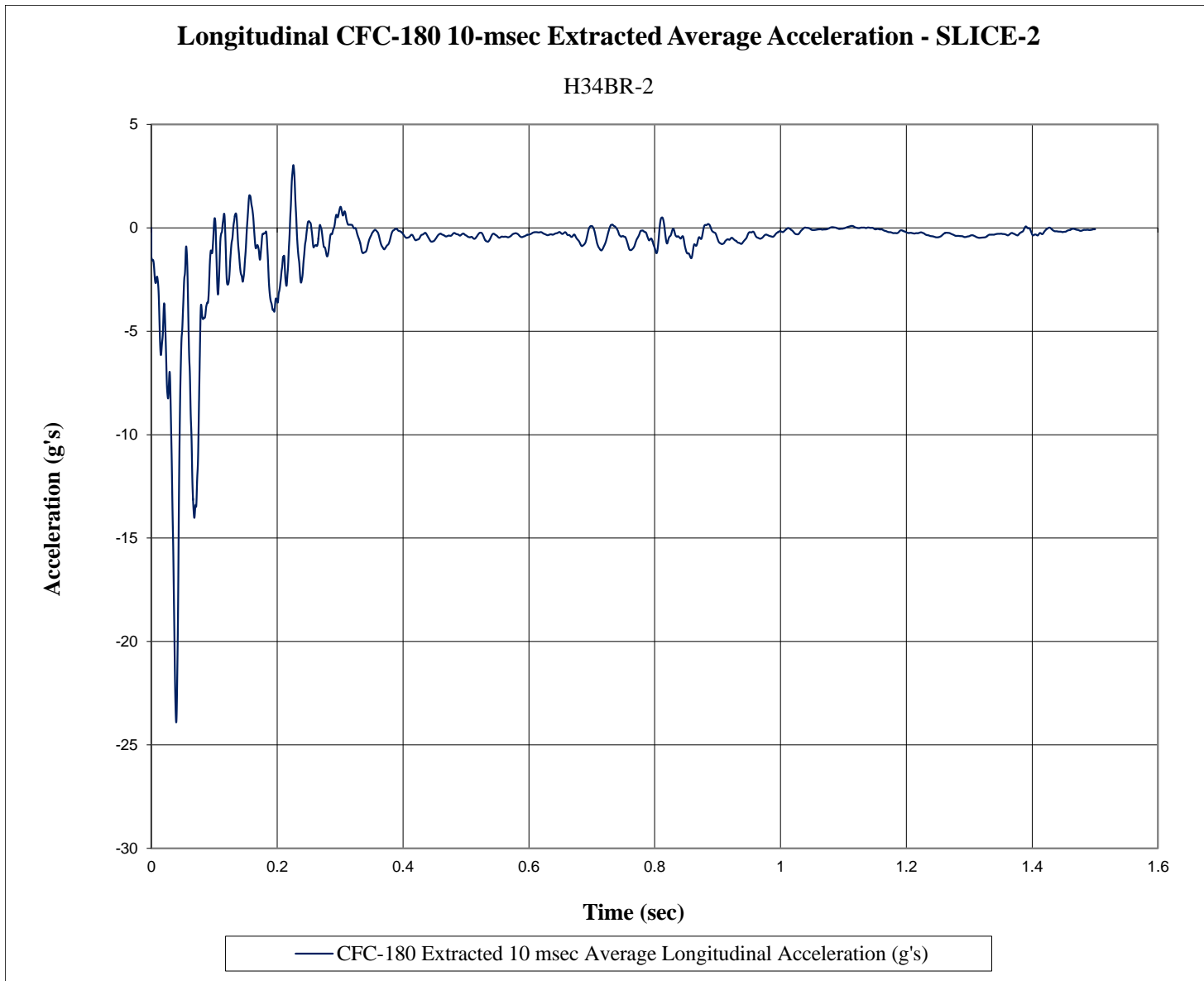

Figure E-9. 10-ms Average Longitudinal Deceleration (SLICE-2), Test No. H34BR-2

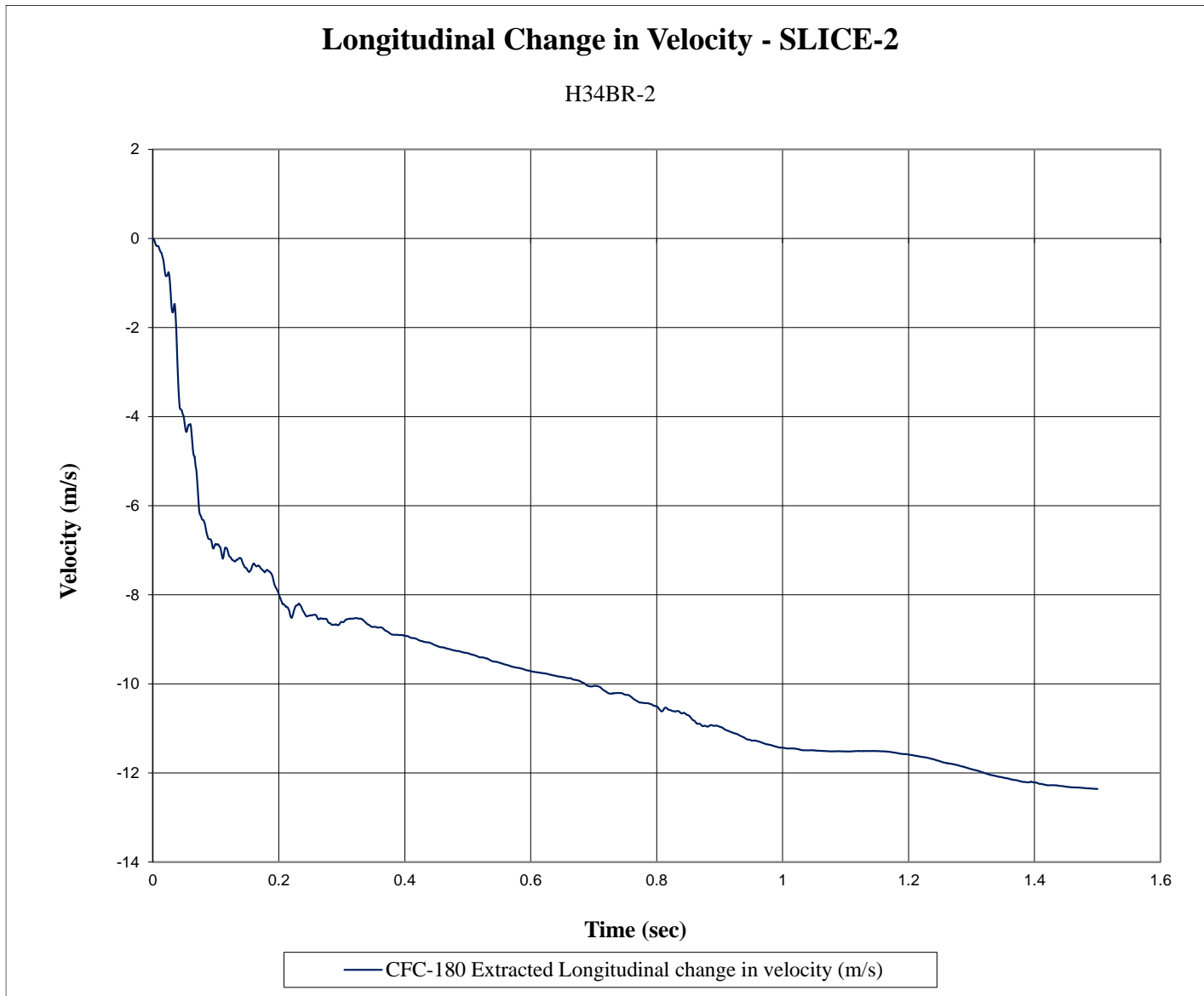

Figure E-10. Longitudinal Occupant Impact Velocity (SLICE-2), Test No. H34BR-2

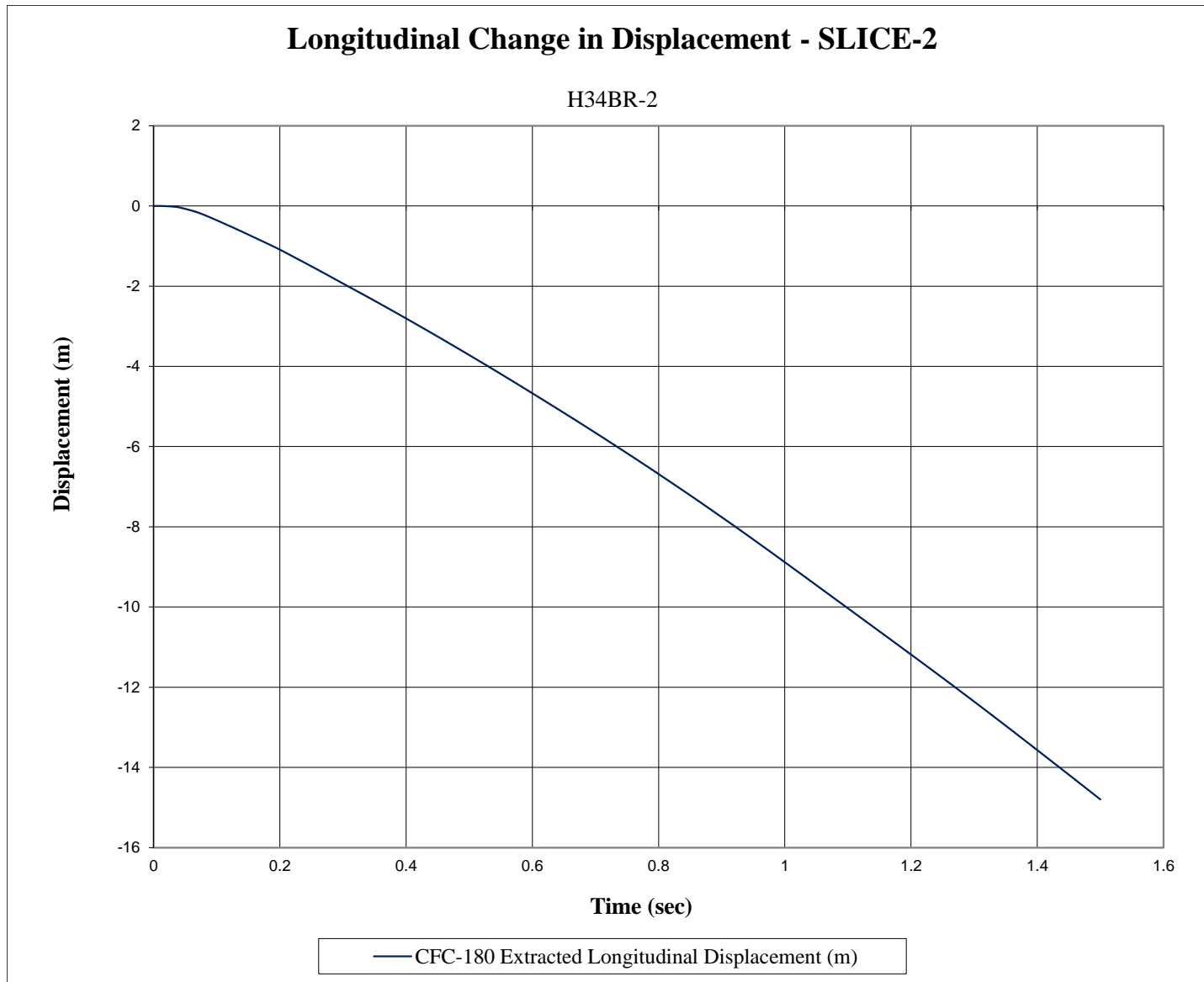

Figure E-11. Longitudinal Occupant Displacement (SLICE-2), Test No. H34BR-2

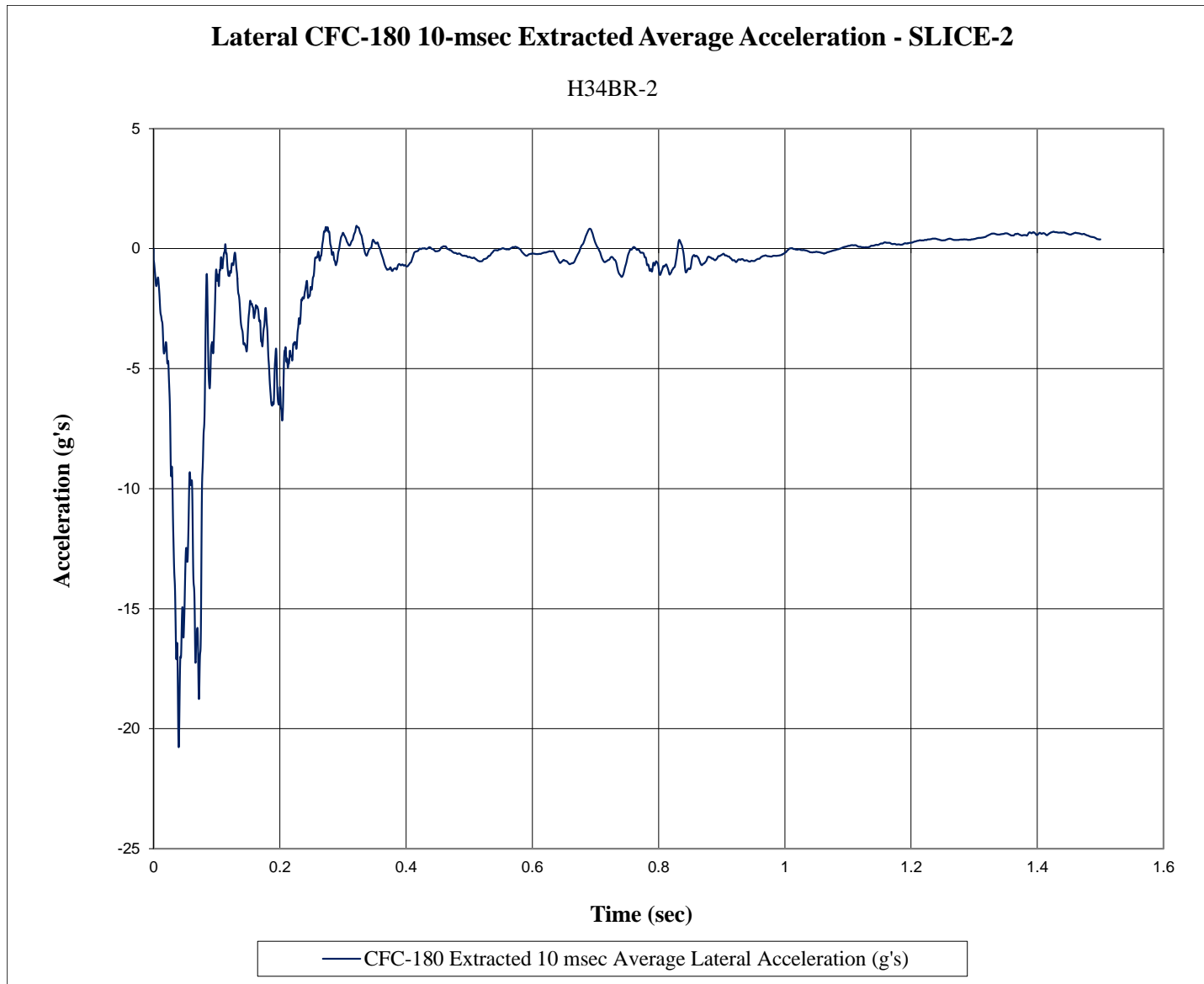

Figure E-12. 10-ms Average Lateral Deceleration (SLICE-2), Test No. H34BR-2

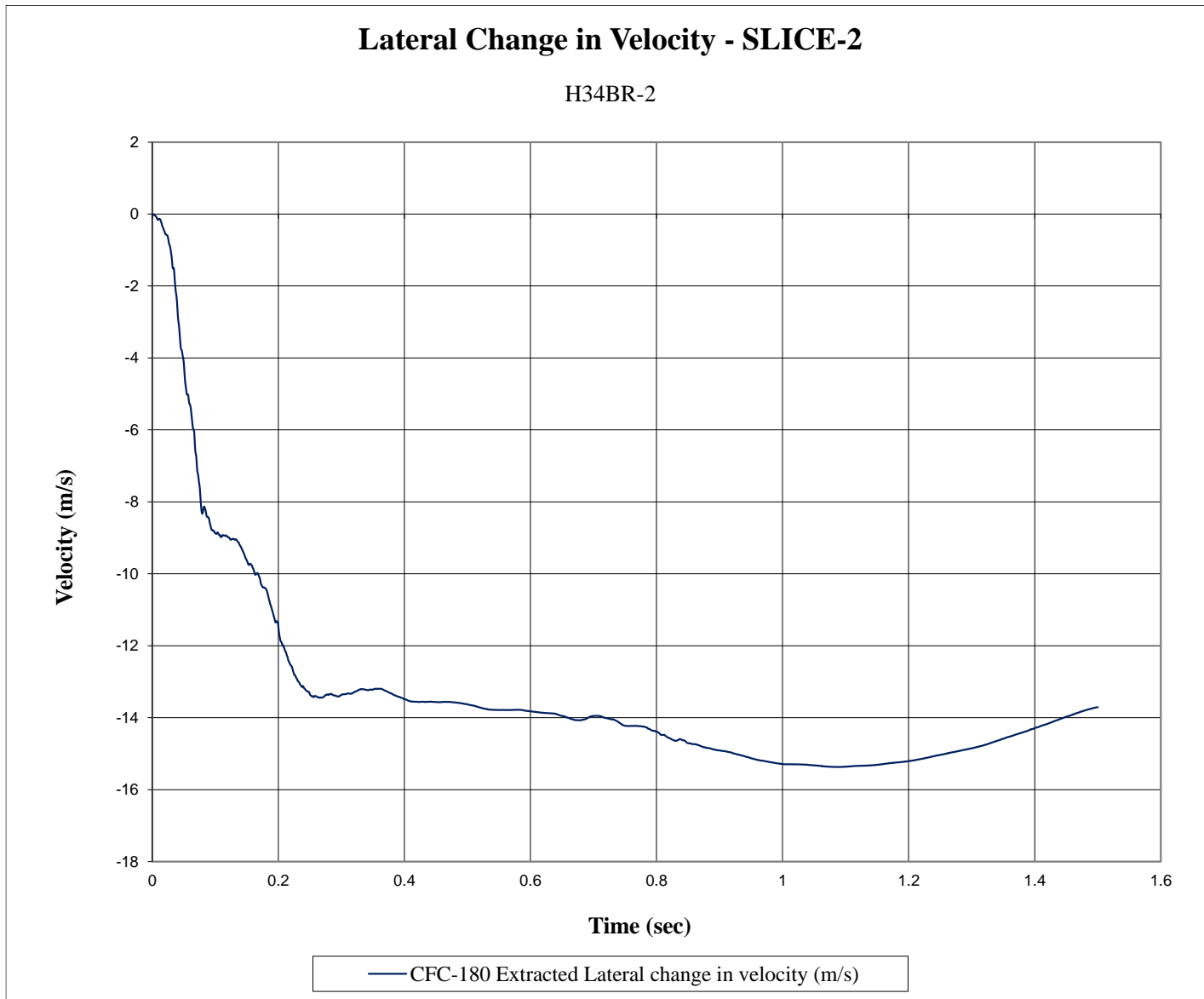

Figure E-13. Lateral Occupant Impact Velocity (SLICE-2), Test No. H34BR-2

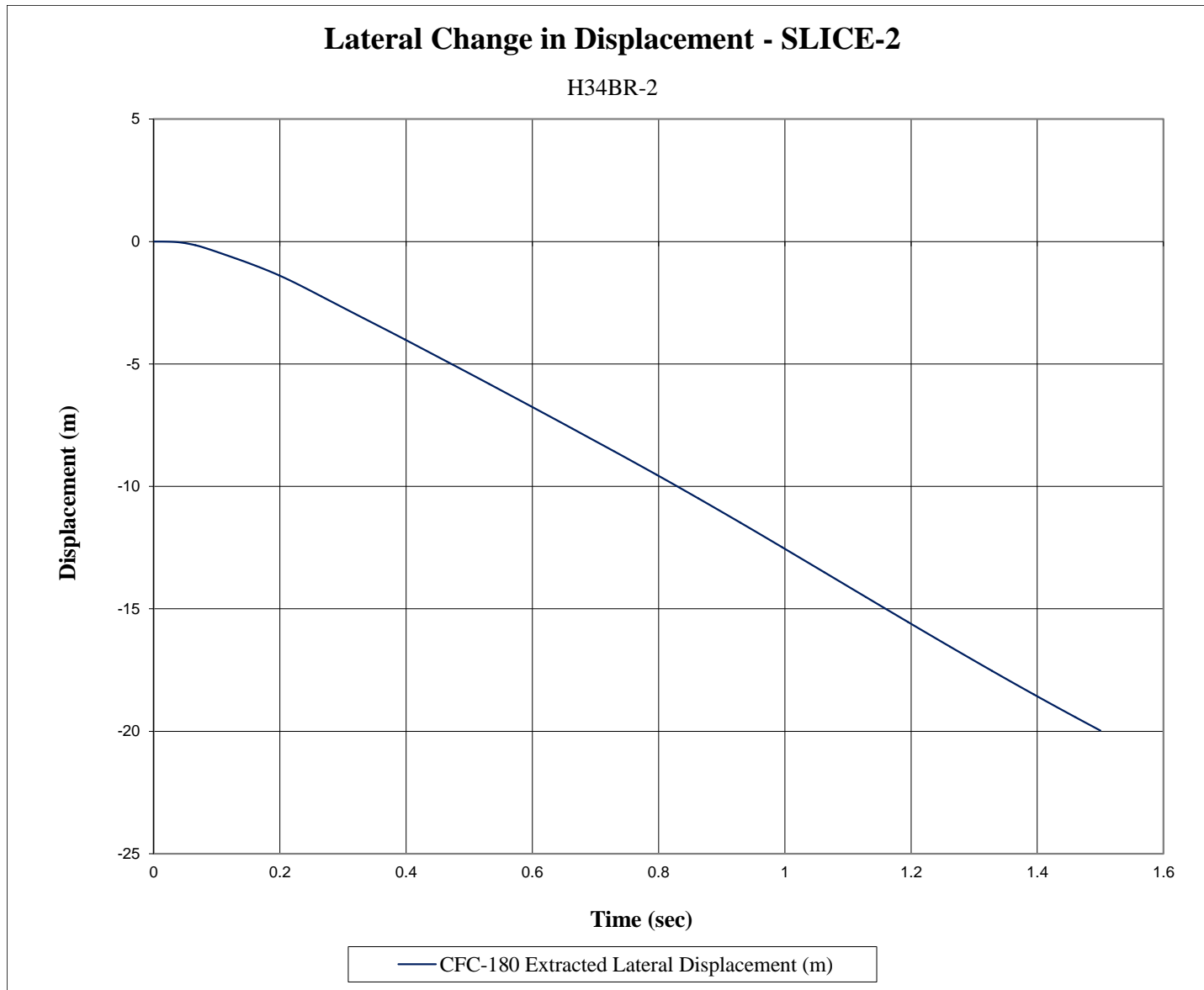

Figure E-14. Lateral Occupant Displacement (SLICE-2), Test No. H34BR-2

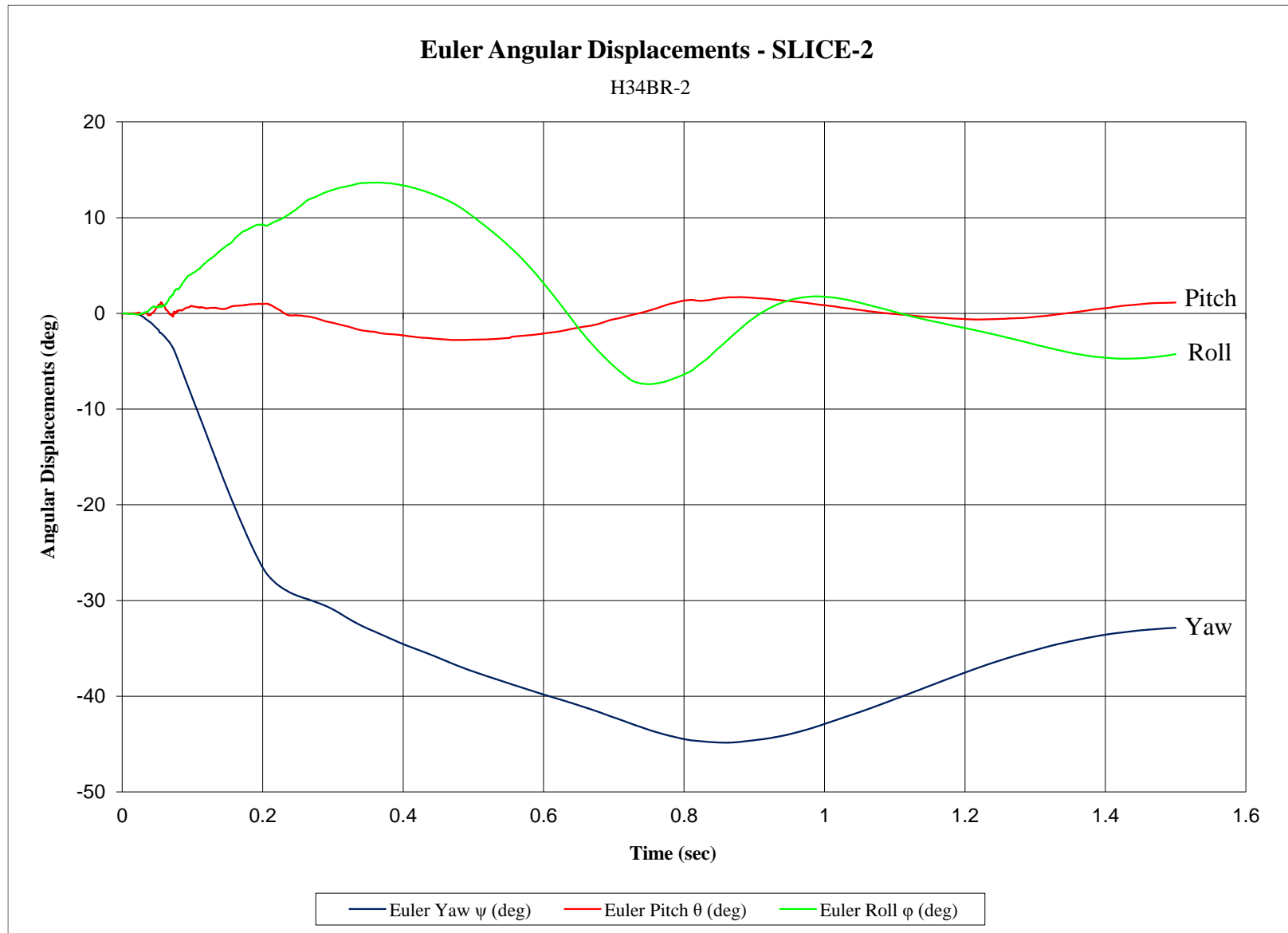

Figure E-15. Vehicle Angular Displacements (SLICE-2), Test No. H34BR-2

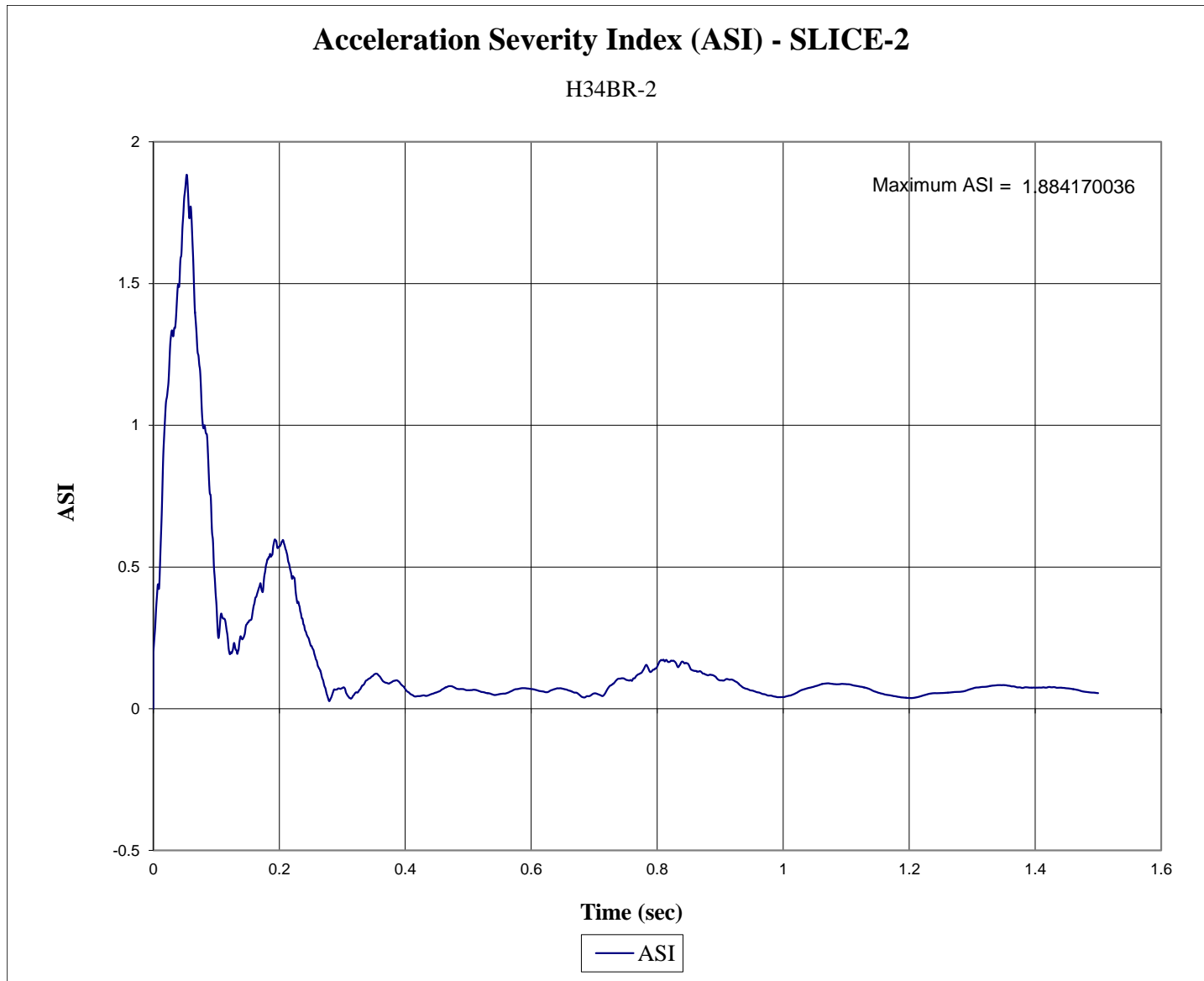

Figure E-16. Acceleration Severity Index (SLICE-2), Test No. H34BR-2

END OF DOCUMENT